

ISO/IEC JTC 1/SC 32 N 1305

Date: 2005-05-05

REPLACES: --

ISO/IEC JTC 1/SC 32

Data Management and Interchange

Secretariat: United States of America (ANSI)
Administered by Farance Inc. on behalf of ANSI

DOCUMENT TYPE	Proposed NP
TITLE	Letter Ballot on NP for SQL-MM History
SOURCE	SC 32 Secretary
PROJECT NUMBER	1.32.04.03.07.00
STATUS	This is a 60 day letter ballot. See 32N1306 for the Working Draft.
REFERENCES	
ACTION ID.	LB
REQUESTED ACTION	
DUE DATE	2005-07-08
Number of Pages	8
LANGUAGE USED	English
DISTRIBUTION	P & L Members SC Chair WG Conveners and Secretaries

Douglas Mann, Secretary, ISO/IEC JTC 1/SC 32

Farance Inc *, 360 Pelissier Lake Road, Marquette, MI 49855-9678, United States of America

Telephone: +1 906-249-9275; E-mail: MannD@battelle.org

available from the JTC 1/SC 32 WebSite <http://jtc1sc32.org/>

*Farance Inc. administers the ISO/IEC JTC 1/SC 32 Secretariat on behalf of ANSI



Title: Proposal for a New Subproject: SQL/MM History

Author: Kenji Suzuki(Japan), Baba Piprani(Canada), Mike Newton(UK),
Christoph Lingenfelder(Germany)

Status: SQL/MM New Subproject Proposal

Source: Expert Contribution

References:

[TXL012] Part-7 History NW proposal

[TXL013] Part-7 History candidate base document

PROPOSAL FOR A NEW WORK ITEM

Date of presentation of proposal: 2005-04-19	Proposer: ISO/IEC JTC1/SC32
Secretariat: National Body	ISO/IEC JTC 1/SC 32 N1305

A proposal for a new work item shall be submitted to the secretariat of the ISO/IEC joint technical committee concerned with a copy to the ISO Central Secretariat.

Presentation of the proposal - to be completed by the proposer.

<p>Title (subject to be covered and type of standard, e.g. terminology, method of test, performance requirements, etc.)</p> <p>Information technology — Database languages — SQL multimedia and application packages — Part 7: History</p>
<p>Scope (and field of application)</p> <p>The standard defines routines and user-defined types to store, manage, and retrieve data recording changes to tables in an SQL database.</p>
<p>Purpose and justification</p> <p>See Attachment.</p> <p>This proposal is intended to extend the SC32 Project 1.32.04 SQL multimedia and application packages (SQL/MM) to add a new subproject for a separate part of SQL/MM multipart standard that will provide the specifications of this application package.</p>
<p>Programme of work</p> <p>If the proposed new work item is approved, which of the following document(s) is (are) expected to be developed?</p> <p><input type="checkbox"/> a single International Standard</p> <p><input type="checkbox"/> more than one International Standard (expected number:)</p> <p><input type="checkbox"/> a multi-part International Standard consisting of parts</p> <p><input type="checkbox"/> an amendment or amendments to the following International Standard(s)</p> <p><input type="checkbox"/> a technical report , type</p> <p>And which standard development track is recommended for the approved new work item?</p> <p><input type="checkbox"/> a. Default Timeframe</p> <p><input type="checkbox"/> b. Accelerated Timeframe</p> <p><input type="checkbox"/> c. Extended Timeframe</p>
<p>Relevant documents to be considered</p> <p>ISO/IEC JTC 1/SC 32/WG 4:TXL-013: Information technology — Database languages — SQL Multimedia and Application Packages — Part 7: History (Part 7:History candidate base document)</p>
<p>Co-operation and liaison</p>
<p>Preparatory work offered with target date(s)</p>
<p>Signature:</p>

Will the service of a maintenance agency or registration authority be required?No.....
 - If yes, have you identified a potential candidate?
 - If yes, indicate name

Are there any known requirements for coding?No.....
 -If yes, please specify on a separate page

Does the proposed standard concern known patented items?No.....
 - If yes, please provide full information in an annex

Comments and recommendations of the JTC 1 or SC XXSecretariat - attach a separate page as an annex, if necessary

Comments with respect to the proposal in general, and recommendations thereon:
 It is proposed to assign this new item to JTC 1/SC 32

Voting on the proposal - Each P-member of the ISO/IEC joint technical committee has an obligation to vote within the time limits laid down (normally three months after the date of circulation).

Date of circulation: YYYY-MM-DD	Closing date for voting: YYYY-MM-DD	Signature of Secretary:
---	---	--------------------------------

NEW WORK ITEM PROPOSAL - PROJECT ACCEPTANCE CRITERIA		
Criterion	Validity	Explanation
A. Business Requirement		
A.1 Market Requirement	Essential <input checked="" type="checkbox"/> Desirable <input type="checkbox"/> Supportive <input type="checkbox"/>	
A.2 Regulatory Context	Essential <input type="checkbox"/> Desirable <input type="checkbox"/> Supportive <input type="checkbox"/> Not Relevant <input checked="" type="checkbox"/>	
B. Related Work		
B.1 Completion/Maintenance of current standards	Yes <input type="checkbox"/> No <input checked="" type="checkbox"/>	
B.2 Commitment to other organisation	Yes <input type="checkbox"/> No <input checked="" type="checkbox"/>	
B.3 Other Source of standards	Yes <input type="checkbox"/> No <input checked="" type="checkbox"/>	
C. Technical Status		

C.1 Mature Technology	Yes <input checked="" type="checkbox"/> No <input type="checkbox"/>	
C.2 Prospective Technology	Yes <input type="checkbox"/> No <input checked="" type="checkbox"/>	
C.3 Models/Tools	Yes <input checked="" type="checkbox"/> No <input type="checkbox"/>	
D. Conformity Assessment and Interoperability		
D.1 Conformity Assessment	Yes <input type="checkbox"/> No <input checked="" type="checkbox"/>	
D.2 Interoperability	Yes <input type="checkbox"/> No <input checked="" type="checkbox"/>	
E. Cultural and Linguistic Adaptability	Yes <input type="checkbox"/> No <input checked="" type="checkbox"/>	
F. Other Justification		

Notes to Proforma

A. Business Relevance. That which identifies market place relevance in terms of what problem is being solved and or need being addressed.

A.1 Market Requirement. When submitting a NP, the proposer shall identify the nature of the Market Requirement, assessing the extent to which it is essential, desirable or merely supportive of some other project.

A.2 Technical Regulation. If a Regulatory requirement is deemed to exist - e.g. for an area of public concern e.g. Information Security, Data protection, potentially leading to regulatory/public interest action based on the use of this voluntary international standard - the proposer shall identify this here.

B. Related Work. Aspects of the relationship of this NP to other areas of standardisation work shall be identified in this section.

B.1 Competition/Maintenance. If this NP is concerned with completing or maintaining existing standards, those concerned shall be identified here.

B.2 External Commitment. Groups, bodies, or fora external to JTC 1 to which a commitment has been made by JTC for Co-operation and or collaboration on this NP shall be identified here.

B.3 External Std/Specification. If other activities creating standards or specifications in this topic area are known to exist or be planned, and which might be available to JTC 1 as PAS, they shall be identified here.

C. Technical Status. The proposer shall indicate here an assessment of the extent to which the proposed standard is supported by current technology.

C.1 Mature Technology. Indicate here the extent to which the technology is reasonably stable and ripe for standardisation.

C.2 Prospective Technology. If the NP is anticipatory in nature based on expected or forecasted need, this shall be indicated here.

C.3 Models/Tools. If the NP relates to the creation of supportive reference models or tools, this shall be indicated here.

D. Conformity Assessment and Interoperability

D.1 Indicate here if Conformity Assessment is relevant to your project. If so, indicate how it is addressed in your project plan.

D.2 Indicate here if Interoperability is relevant to your project. If so, indicate how it is addressed in your project plan

E. Cultural and Linguistic Adaptability Indicate here if cultural and linguistic adaptability is applicable to your project. If so, indicate how it is addressed in your project plan.

F. Other Justification Any other aspects of background information justifying this NP shall be indicated here

Purpose and Justification for the NWI: SQL/MM History

1. Business Relevance

There are many business information systems which not only store current values of data but also are required to track the changes to that data.. Examples of such database applications are as follows.

- Personnel information on employee records such as the changes of title, salary, and affiliation section.
- Medical information on patient records such as diagnostic history.
- Auditing records for compliance purposes.

These situations are common across a wide range of business applications. There is a need for a standard approach that can enable the development of software to support the automatic recording of such changes to data.

2. Purpose of SQL/MM History

The purpose of SQL/MM History is to provide routines and user-defined types able to record changes to existing base tables in an SQL database. These routines and user-defined types can also retrieve the contents of a table as recorded at any past time.

It is intended that these routines and user-defined types can be used without affecting existing base tables and their related application programs.

3. Overview of SQL History Routines and User-defined Types

Figure 1 below depicts a model of the usage of the routines and user-defined types of the proposed standard. It does not prescribe a particular method of how the routines and user-defined types are to be implemented.

In the lower SQL layer, existing application programs make changes to a database table. When history data is required for this table, a history processing application creates a history table through a procedure provided in the SQL/MM History layer. When the existing application in the SQL layer executes Insert, Update or Delete operation, then Insert/Update/Delete triggers provided by SQL/MM History layer insert history rows into the

history table. The history processing application can execute a function invocation to retrieve from the history table.

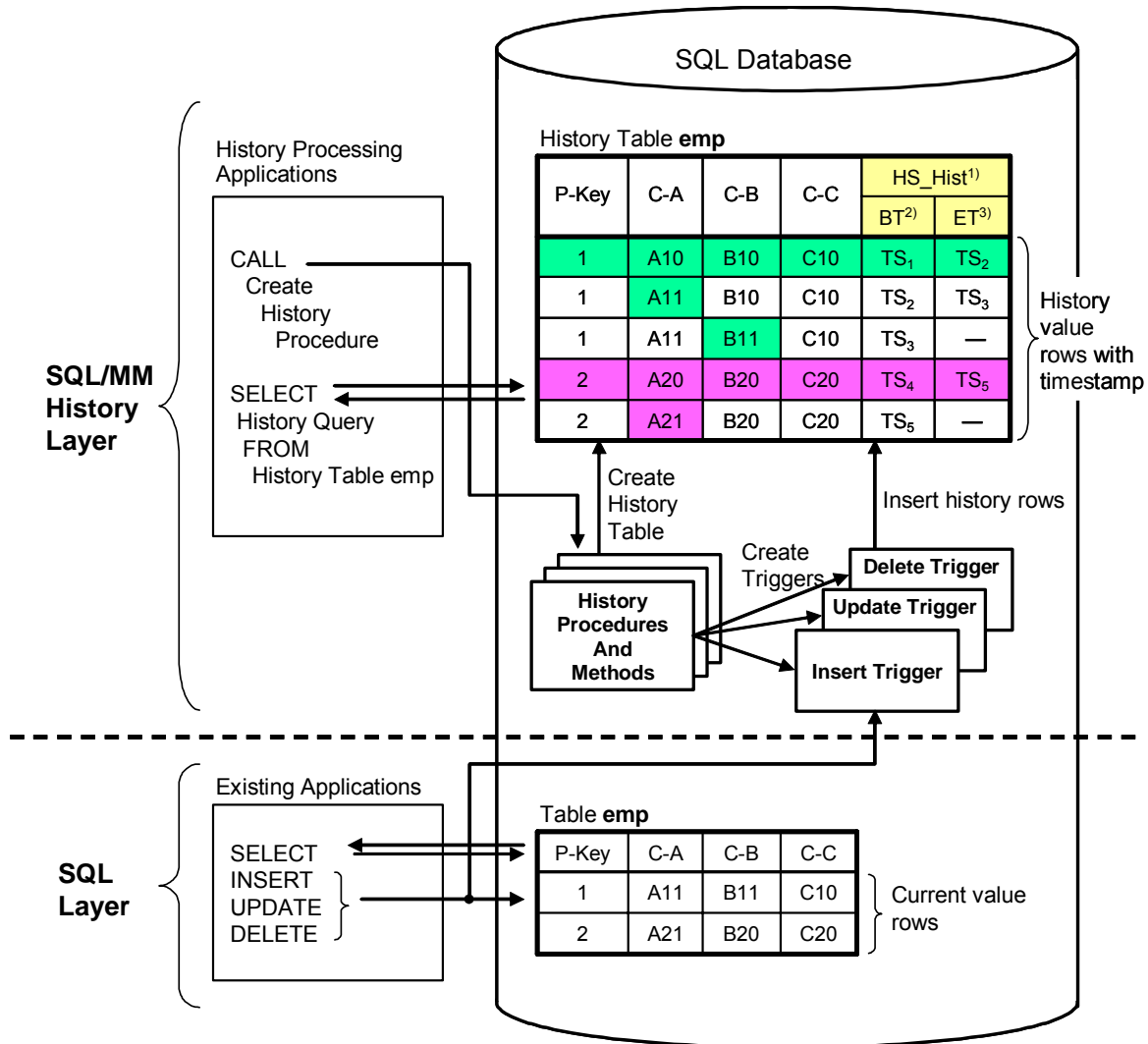

Note 1) Column of structured type HS_History defined by SQL/MM History
 2) BT: HS_HistoryBeginTime
 3) ET: HS_HistoryEndTime

Figure 1. Model of SQL and SQL/MM History Layers