

Committee Draft ISO/IEC CD	
Date: 2004-12-15	Reference number: ISO/JTC 1/SC 32N1203
Supersedes document SC 32N1009	

THIS DOCUMENT IS STILL UNDER STUDY AND SUBJECT TO CHANGE. IT SHOULD NOT BE USED FOR REFERENCE PURPOSES.

ISO/IEC JTC 1/SC 32 Data Management and Interchange Secretariat: USA (ANSI)	Circulated to P- and O-members, and to technical committees and organizations in liaison for voting (P-members only) by: 2005-03-15 Please return all votes and comments in electronic form directly to the SC 32 Secretariat by the due date indicated.
--	---

ISO/IEC CD 9075-09:200x(E) Title: Information technology — Database Languages - SQL - Part 9: Management of External Data (SQL/MED) Project: 1.32.03.06.09.00
--

Introductory note: The attached document is hereby submitted for a three-month letter ballot to the National Bodies of ISO/IEC JTC 1/SC 32. The ballot starts 2004-12-15.

Medium: E

No. of pages: 489

Address Reply to: Douglas Mann, Secretariat, ISO/IEC JTC 1/SC 32, Pacific Northwest National Laboratory, 13667 Legacy Circle Apt H, Herndon, VA, 20171, United States of America

Telephone: +1 202-566-2126; Facsimile: +1 202-566-1639; E-mail: MannD@battelle.org

ISO/IEC JTC 1/SC 32

Date: 2004-12-11

CD ISO/IEC 9075-9:2007 (E)

ISO/IEC JTC 1/SC 32/WG 3

The Netherlands (NNI)

Information technology — Database languages — SQL —

**Part 9:
Management of External Data (SQL/MED)**

*Technologies de l'information — Langages de base de données — SQL —
Partie 9: Gestion des Données Externes (SQL/MED)*

Document type: International Standard
Document subtype: Committee Draft (CD)
Document stage: (3) CD under Consideration
Document language: English

Copyright notice

This ISO document is a working draft or a committee draft and is copyright-protected by ISO. While the reproduction of working drafts or committee drafts in any form for use by participants in the ISO standards development process is permitted without prior permission from ISO, neither this document nor any extract from it may be reproduced, stored or transmitted in any form for any other purpose without prior written permission from ISO.

Requests for permission to reproduce for the purpose of selling it should be addressed as shown below or to ISO's member body in the country of the requester.

*ANSI Customer Service Department
25 West 43rd Street, 4th Floor
New York, NY 10036
Tele: 1-212-642-4980
Fax: 1-212-302-1286
Email: storemanager@ansi.org
Web: www.ansi.org*

Reproduction for sales purposes may be subject to royalty payments or a licensing agreement.

Violators may be prosecuted.

Contents

Page

Foreword.....	xv
Introduction.....	xvi
1 Scope.....	1
2 Normative references.....	3
2.1 ISO/IEC JTC 1 standards.....	3
2.2 Other international standards.....	3
3 Definitions, notations, and conventions.....	5
3.1 Definitions.....	5
3.1.1 Definitions taken from XML.....	5
3.1.2 Definitions provided in Part 9.....	5
4 Concepts.....	7
4.1 Data types.....	7
4.1.1 Naming of predefined types.....	7
4.1.2 Comparison and ordering.....	7
4.2 Foreign servers.....	7
4.3 Foreign-data wrappers.....	8
4.4 User mappings.....	9
4.5 Routine mappings.....	9
4.6 Generic options.....	10
4.7 Capabilities and options information.....	11
4.8 Datalinks.....	11
4.8.1 Operations involving datalinks.....	15
4.8.1.1 Operators that operate on datalinks.....	15
4.8.1.2 Other operators involving datalinks.....	16
4.9 Columns, fields, and attributes.....	16
4.10 Tables.....	16
4.10.1 Types of tables.....	16
4.10.2 Table descriptors.....	17
4.10.3 Relationships between tables.....	17
4.11 Functional dependencies.....	17
4.11.1 Overview of functional dependency rules and notations.....	17
4.11.2 Known functional dependencies in a foreign table.....	18
4.12 SQL-schemas.....	18
4.13 SQL-statements.....	18
4.13.1 SQL-statements classified by function.....	18

4.13.1.1	SQL-schema statements.	18
4.13.1.2	SQL-session statements.	19
4.14	Basic security model.	19
4.14.1	Privileges.	19
4.15	SQL-transactions.	20
4.15.1	Properties of SQL-transactions.	20
4.16	SQL-sessions.	20
4.16.1	SQL-session properties.	20
4.17	Foreign-data wrapper interface.	21
4.17.1	Handles.	21
4.17.2	Foreign server sessions.	23
4.17.3	Foreign-data wrapper interface routines.	23
4.17.3.1	Handle routines.	23
4.17.3.2	Initialization routines.	27
4.17.3.3	Access routines.	28
4.17.3.4	Termination routines.	29
4.17.3.5	Decomposition and pass-through modes.	29
4.17.3.6	Sequence of actions during the execution of foreign server requests.	29
4.17.4	Return codes.	41
4.17.5	Foreign-data wrapper diagnostics areas.	42
4.17.6	Null pointers.	44
4.17.7	Foreign-data wrapper descriptor areas.	44
4.18	Introduction to SQL/CLI.	47
5	Lexical elements.	49
5.1	<token> and <separator>.	49
5.2	Names and identifiers.	51
6	Scalar expressions.	53
6.1	<data type>.	53
6.2	<cast specification>.	56
6.3	<value expression>.	58
6.4	<string value function>.	59
6.5	<datalink value expression>.	63
6.6	<datalink value function>.	64
7	Query expressions.	67
7.1	<table reference>.	67
8	URLs.	75
8.1	URL format.	75
9	Additional common rules.	79
9.1	Retrieval assignment.	79
9.2	Store assignment.	80
9.3	Data types of results of aggregations.	81
9.4	Type precedence list determination.	82

9.5	Determination of identical values.	83
9.6	Equality operations.	84
9.7	Grouping operations.	85
9.8	Multiset element grouping operations.	86
9.9	Ordering operations.	87
10	Additional common elements.	89
10.1	<generic options>.	89
10.2	<alter generic options>.	90
11	Schema definition and manipulation.	93
11.1	<schema definition>.	93
11.2	<drop schema statement>.	94
11.3	<table definition>.	95
11.4	<unique constraint definition>.	96
11.5	<check constraint definition>.	97
11.6	<drop column definition>.	98
11.7	<domain definition>.	99
11.8	<assertion definition>.	100
11.9	<user-defined type definition>.	101
11.10	<SQL-invoked routine>.	102
11.11	<drop routine statement>.	103
11.12	<user-defined cast definition>.	104
11.13	<user-defined ordering definition>.	105
11.14	<foreign table definition>.	106
11.15	<alter foreign table statement>.	109
11.16	<add basic column definition>.	111
11.17	<alter basic column definition>.	113
11.18	<drop basic column definition>.	114
11.19	<drop foreign table statement>.	116
12	Catalog manipulation.	119
12.1	<foreign server definition>.	119
12.2	<alter foreign server statement>.	121
12.3	<drop foreign server statement>.	122
12.4	<foreign-data wrapper definition>.	124
12.5	<alter foreign-data wrapper statement>.	126
12.6	<drop foreign-data wrapper statement>.	127
12.7	<import foreign schema statement>.	128
12.8	<routine mapping definition>.	130
12.9	<alter routine mapping statement>.	132
12.10	<drop routine mapping statement>.	133
13	Access control.	135
13.1	<privileges>.	135
13.2	<revoke statement>.	136
13.3	<user mapping definition>.	138

13.4	<alter user mapping statement>.....	140
13.5	<drop user mapping statement>.....	141
14	SQL-client modules.....	143
14.1	<SQL-client module definition>.....	143
14.2	<externally-invoked procedure>.....	145
14.3	Calls to an <externally-invoked procedure>.....	146
14.4	<SQL procedure statement>.....	149
14.5	Data type correspondences.....	151
15	Data manipulation.....	155
15.1	Effect of deleting rows from base tables.....	155
15.2	Effect of inserting tables into base tables.....	157
15.3	Effect of replacing rows in base tables.....	159
16	Session management.....	161
16.1	<set passthrough statement>.....	161
17	Dynamic SQL.....	163
17.1	Description of SQL descriptor areas.....	163
17.2	<prepare statement>.....	165
17.3	<deallocate prepared statement>.....	167
17.4	<describe statement>.....	168
17.5	<input using clause>.....	170
17.6	<output using clause>.....	174
17.7	<execute statement>.....	178
17.8	<dynamic declare cursor>.....	179
17.9	<allocate cursor statement>.....	180
17.10	<dynamic open statement>.....	181
17.11	<dynamic fetch statement>.....	182
17.12	<dynamic close statement>.....	183
18	Embedded SQL.....	185
18.1	<embedded SQL Ada program>.....	185
18.2	<embedded SQL C program>.....	187
18.3	<embedded SQL COBOL program>.....	188
18.4	<embedded SQL Fortran program>.....	189
18.5	<embedded SQL MUMPS program>.....	190
18.6	<embedded SQL Pascal program>.....	191
18.7	<embedded SQL PL/I program>.....	192
19	Call-Level Interface specifications.....	193
19.1	<CLI routine>.....	193
19.2	Implicit DESCRIBE USING clause.....	194
19.3	Description of CLI item descriptor areas.....	194
19.4	Other tables associated with CLI.....	195
19.5	SQL/CLI data type correspondences.....	198
20	SQL/CLI routines.....	201

20.1	BuildDataLink.....	201
20.2	GetDataLinkAttr.....	203
20.3	GetInfo.....	205
21	SQL/MED common specifications.....	207
21.1	Description of foreign-data wrapper item descriptor areas.....	207
21.2	Implicit cursor.....	211
21.3	Implicit DESCRIBE INPUT USING clause.....	213
21.4	Implicit DESCRIBE OUTPUT USING clause.....	216
21.5	Implicit EXECUTE USING and OPEN USING clauses.....	219
21.6	Implicit FETCH USING clause.....	222
21.7	Character string retrieval.....	226
21.8	Binary large object string retrieval.....	227
21.9	Tables used with SQL/MED.....	228
22	Foreign-data wrapper interface routines.....	239
22.1	<foreign-data wrapper interface routine>.....	239
22.2	<foreign-data wrapper interface routine> invocation.....	244
22.3	Foreign-data wrapper interface wrapper routines.....	246
22.3.1	AdvanceInitRequest.....	246
22.3.2	AllocQueryContext.....	248
22.3.3	AllocWrapperEnv.....	249
22.3.4	Close.....	251
22.3.5	ConnectServer.....	252
22.3.6	FreeExecutionHandle.....	254
22.3.7	FreeFSConnection.....	256
22.3.8	FreeQueryContext.....	257
22.3.9	FreeReplyHandle.....	258
22.3.10	FreeWrapperEnv.....	259
22.3.11	GetNextReply.....	260
22.3.12	GetNumReplyBoolVE.....	261
22.3.13	GetNumReplyOrderBy.....	262
22.3.14	GetNumReplySelectElems.....	263
22.3.15	GetNumReplyTableRefs.....	264
22.3.16	GetOpts.....	265
22.3.17	GetReplyBoolVE.....	267
22.3.18	GetReplyCardinality.....	268
22.3.19	GetReplyDistinct.....	269
22.3.20	GetReplyExecCost.....	270
22.3.21	GetReplyFirstCost.....	271
22.3.22	GetReplyOrderElem.....	272
22.3.23	GetReplyReExecCost.....	273
22.3.24	GetReplySelectElem.....	274
22.3.25	GetReplyTableRef.....	275
22.3.26	GetSPDHandle.....	276

22.3.27	GetSRDHandle.	277
22.3.28	GetStatistics.	278
22.3.29	GetWPDHandle.	280
22.3.30	GetWRDHandle.	281
22.3.31	InitRequest.	282
22.3.32	Iterate.	286
22.3.33	Open.	288
22.3.34	ReOpen.	292
22.3.35	TransmitRequest.	293
22.4	Foreign-data wrapper interface SQL-server routines.	296
22.4.1	AllocDescriptor.	296
22.4.2	FreeDescriptor.	297
22.4.3	GetAuthorizationId.	298
22.4.4	GetBoolVE.	299
22.4.5	GetDescriptor.	300
22.4.6	GetDistinct.	302
22.4.7	GetNumBoolVE.	303
22.4.8	GetNumChildren.	304
22.4.9	GetNumOrderByElems.	305
22.4.10	GetNumRoutMapOpts.	306
22.4.11	GetNumSelectElems.	307
22.4.12	GetNumServerOpts.	308
22.4.13	GetNumTableColOpts.	309
22.4.14	GetNumTableOpts.	311
22.4.15	GetNumTableRefElems.	312
22.4.16	GetNumUserOpts.	313
22.4.17	GetNumWrapperOpts.	314
22.4.18	GetOrderByElem.	315
22.4.19	GetRoutMapOpt.	316
22.4.20	GetRoutMapOptName.	318
22.4.21	GetRoutineMapping.	320
22.4.22	GetSelectElem.	321
22.4.23	GetSelectElemType.	322
22.4.24	GetServerName.	323
22.4.25	GetServerOpt.	324
22.4.26	GetServerOptByName.	326
22.4.27	GetServerType.	328
22.4.28	GetServerVersion.	329
22.4.29	GetSQLString.	330
22.4.30	GetTableColOpt.	332
22.4.31	GetTableColOptByName.	334
22.4.32	GetTableOpt.	336
22.4.33	GetTableOptByName.	338
22.4.34	GetTableRefElem.	340

22.4.35	GetTableRefElemType.	341
22.4.36	GetTableRefTableName.	342
22.4.37	GetTableServerName.	343
22.4.38	GetTRDHandle.	344
22.4.39	GetUserOpt.	345
22.4.40	GetUserOptByName.	347
22.4.41	GetValExprColName.	349
22.4.42	GetValueExpDesc.	350
22.4.43	GetValueExpKind.	351
22.4.44	GetValueExpName.	352
22.4.45	GetValueExpTable.	353
22.4.46	GetVEChild.	354
22.4.47	GetWrapperLibraryName.	355
22.4.48	GetWrapperName.	356
22.4.49	GetWrapperOpt.	357
22.4.50	GetWrapperOptByName.	359
22.4.51	SetDescriptor.	361
22.5	Foreign-data wrapper interface general routines.	366
22.5.1	GetDiagnostics.	366
23	Diagnostics management.	371
23.1	<get diagnostics statement>.	371
24	Information Schema.	373
24.1	ATTRIBUTES view.	373
24.2	COLUMN_OPTIONS view.	374
24.3	COLUMNS view.	375
24.4	FOREIGN_DATA_WRAPPER_OPTIONS view.	376
24.5	FOREIGN_DATA_WRAPPERS view.	377
24.6	FOREIGN_SERVER_OPTIONS view.	378
24.7	FOREIGN_SERVERS view.	379
24.8	FOREIGN_TABLE_OPTIONS view.	380
24.9	FOREIGN_TABLES view.	381
24.10	ROUTINE_MAPPING_OPTIONS view.	382
24.11	ROUTINE_MAPPINGS view.	383
24.12	USER_MAPPING_OPTIONS view.	384
24.13	USER_MAPPINGS view.	385
24.14	Short name views.	386
25	Definition Schema.	391
25.1	COLUMN_OPTIONS base table.	391
25.2	DATA_TYPE_DESCRIPTOR base table.	392
25.3	FOREIGN_DATA_WRAPPER_OPTIONS base table.	400
25.4	FOREIGN_DATA_WRAPPERS base table.	401
25.5	FOREIGN_SERVER_OPTIONS base table.	402
25.6	FOREIGN_SERVERS base table.	403

25.7	FOREIGN_TABLE_OPTIONS base table.	404
25.8	FOREIGN_TABLES base table.	405
25.9	ROUTINE_MAPPING_OPTIONS base table.	406
25.10	ROUTINE_MAPPINGS base table.	407
25.11	SQL_SIZING base table.	408
25.12	TABLES base table.	409
25.13	USAGE_PRIVILEGES base table.	410
25.14	USER_MAPPING_OPTIONS base table.	411
25.15	USER_MAPPINGS base table.	412
26	Status codes.	413
26.1	SQLSTATE.	413
27	Conformance.	417
27.1	Claims of conformance to SQL/MED.	417
27.2	Additional conformance requirements for SQL/MED.	417
Annex A	SQL Conformance Summary.	421
Annex B	Implementation-defined elements.	441
Annex C	Implementation-dependent elements.	449
Annex D	Incompatibilities with ISO/IEC 9075:1999.	453
Annex E	Typical header files.	455
E.1	C Header File SQLCLI.H.	455
E.2	COBOL Library Item SQLCLI.	455
Annex F	SQL feature taxonomy.	457
Annex G	SQL/MED model.	459
Index.		463

Tables

Table	Page
1 Valid datalink file control options.	14
2 Sequence of actions during the execution of foreign server requests.	30
3 Fields used in foreign-data wrapper diagnostics areas.	43
4 Fields in foreign-data wrapper descriptor areas.	45
5 Data type correspondences for Ada.	151
6 Data type correspondences for C.	151
7 Data type correspondences for COBOL.	152
8 Data type correspondences for Fortran.	152
9 Data type correspondences for M.	152
10 Data type correspondences for Pascal.	153
11 Data type correspondences for PL/I.	153
12 Codes used for SQL data types in Dynamic SQL.	163
13 Abbreviated SQL/CLI generic names.	193
14 Codes used for implementation data types in SQL/CLI.	195
15 Codes used for application data types in SQL/CLI.	195
16 Codes used to identify SQL/CLI routines.	195
17 Codes and data types for implementation information.	196
18 Codes used for datalink attributes.	196
19 Data types of attributes.	196
20 SQL/CLI data type correspondences for Ada.	198
21 SQL/CLI data type correspondences for C.	198
22 SQL/CLI data type correspondences for COBOL.	199
23 SQL/CLI data type correspondences for Fortran.	199
24 SQL/CLI data type correspondences for M.	199
25 SQL/CLI data type correspondences for Pascal.	199
26 SQL/CLI data type correspondences for PL/I.	200
27 Codes used for <table reference> types.	228
28 Codes used for <value expression> kinds.	228
29 Codes used for foreign-data wrapper diagnostic fields.	228
30 Codes used for foreign-data wrapper descriptor fields.	229
31 Codes used for foreign-data wrapper handle types.	231
32 Ability to retrieve foreign-data wrapper descriptor fields.	232
33 Ability to set foreign-data wrapper descriptor fields.	234
34 Foreign-data wrapper descriptor field default values.	236
35 Codes used for the format of the character string transmitted by GetSQLString().	238
36 SQL-statement codes.	371
37 SQLSTATE class and subclass values.	413
38 Implied feature relationships of SQL/MED.	419
39 Feature taxonomy for optional features.	457

CD ISO/IEC 9075-9:2007 (E)

40 Legend for SQL/MED interfaces. 459
41 Legend for SQL/MED information flow. 461

Figures

Figure		Page
1	SQL/MED interfaces.....	459
2	SQL/MED information flow.....	461

(Blank page)

Foreword

ISO (the International Organization for Standardization) and IEC (the International Electrotechnical Commission) form the specialized system for worldwide standardization. National bodies that are members of ISO or IEC participate in the development of International Standards through technical committees established by the respective organization to deal with particular fields of technical activity. ISO and IEC technical committees collaborate in fields of mutual interest. Other international organizations, governmental and non-governmental, in liaison with ISO and IEC, also take part in the work.

International Standards are drafted in accordance with the rules given in the ISO/IEC Directives, Part 2.

In the field of information technology, ISO and IEC have established a joint technical committee, ISO/IEC JTC 1. Draft International Standards adopted by the joint technical committee are circulated to national bodies for voting. Publication as an International Standard requires approval by at least 75% of the national bodies casting a vote.

Attention is drawn to the possibility that some of the elements of this International Standard may be the subject of patent rights. ISO and IEC shall not be held responsible for identifying any or all such patent rights.

International Standard ISO/IEC 9075-9 was prepared by Joint Technical Committee ISO/IEC JTC 1, *Information technology*, Subcommittee SC 32, *Data management and interchange*.

ISO/IEC 9075 consists of the following parts, under the general title Information technology — Database languages — SQL:

- Part 1: Framework (SQL/Framework)
- Part 2: Foundation (SQL/Foundation)
- Part 3: Call-Level Interface (SQL/CLI)
- Part 4: Persistent Stored Modules (SQL/PSM)
- Part 9: Management of External Data (SQL/MED)
- Part 10: Object Language Bindings (SQL/OLB)
- Part 11: Information and Definition Schemas (SQL/Schemata)
- Part 13: SQL Routines & Types Using the Java™ Programming Language (SQL/JRT)
- Part 14: XML-Related Specifications (SQL/XML)

Annexes A, B, C, D, E, F, and G of this part of ISO/IEC 9075 are for information only.

Introduction

The organization of this part of ISO/IEC 9075 is as follows:

- 1) Clause 1, “Scope”, specifies the scope of this part of ISO/IEC 9075.
- 2) Clause 2, “Normative references”, identifies additional standards that, through reference in this part of ISO/IEC 9075, constitute provisions of this part of ISO/IEC 9075.
- 3) Clause 3, “Definitions, notations, and conventions”, defines the notations and conventions used in this part of ISO/IEC 9075.
- 4) Clause 4, “Concepts”, presents concepts related to this part of ISO/IEC 9075.
- 5) Clause 5, “Lexical elements”, defines the lexical elements of the language specified in this part of ISO/IEC 9075.
- 6) Clause 6, “Scalar expressions”, defines the elements of the language that produce scalar values.
- 7) Clause 7, “Query expressions”, defines the elements of the language that produce rows and tables of data.
- 8) Clause 8, “URLs”, specifies the format of URLs used in this part of ISO/IEC 9075.
- 9) Clause 9, “Additional common rules”, specifies the rules for assignments that retrieve data from or store data into SQL-data, and formation rules for set operations.
- 10) Clause 10, “Additional common elements”, defines additional common elements used in the definition of foreign tables, foreign servers, and foreign-data wrappers.
- 11) Clause 11, “Schema definition and manipulation”, defines facilities related to foreign tables and datalink type support for creating and managing a schema.
- 12) Clause 12, “Catalog manipulation”, defines facilities for creating, altering, and dropping foreign servers and foreign-data wrappers.
- 13) Clause 13, “Access control”, defines facilities for controlling access to SQL-data.
- 14) Clause 14, “SQL-client modules”, defines SQL-client modules and externally-invoked procedures.
- 15) Clause 15, “Data manipulation”, defines the data manipulation statements.
- 16) Clause 16, “Session management”, defines the SQL-session management statements.
- 17) Clause 17, “Dynamic SQL”, defines the dynamic SQL statements.
- 18) Clause 18, “Embedded SQL”, defines the embedded SQL statements.
- 19) Clause 19, “Call-Level Interface specifications”, defines facilities for using SQL through a Call-Level Interface.
- 20) Clause 20, “SQL/CLI routines”, defines each of the routines that comprise the Call-Level Interface.
- 21) Clause 21, “SQL/MED common specifications”, specifies common facilities used by SQL/MED.
- 22) Clause 22, “Foreign-data wrapper interface routines”, specifies the interaction between an SQL-server and a foreign-data wrapper.

- 23) Clause 23, “Diagnostics management”, defines the diagnostics management facilities.
- 24) Clause 24, “Information Schema”, defines viewed tables that contain schema information.
- 25) Clause 25, “Definition Schema”, defines base tables on which the viewed tables containing schema information depend.
- 26) Clause 26, “Status codes”, defines values that identify the status of the execution of SQL-statements and the mechanisms by which those values are returned.
- 27) Clause 27, “Conformance”, specifies the way in which conformance to this part of ISO/IEC 9075 may be claimed.
- 28) Annex A, “SQL Conformance Summary”, is an informative Annex. It summarizes the conformance requirements of the SQL language.
- 29) Annex B, “Implementation-defined elements”, is an informative Annex. It lists those features for which this part of ISO/IEC 9075 states that the syntax, the meaning, the returned results, the effect on SQL-data and/or schemas, or any other behavior is partly or wholly implementation-defined.
- 30) Annex C, “Implementation-dependent elements”, is an informative Annex. It lists those features for which this part of ISO/IEC 9075 states that the syntax, the meaning, the returned results, the effect on SQL-data and/or schemas, or any other behavior is partly or wholly implementation-dependent.
- 31) Annex D, “Incompatibilities with ISO/IEC 9075:1999”, is an informative Annex. It lists incompatibilities with the previous version of ISO/IEC 9075.
- 32) Annex E, “Typical header files”, is an informative Annex. It provides examples of typical definition files for application programs using the SQL Call-Level Interface.
- 33) Annex F, “SQL feature taxonomy”, is an informative Annex. It identifies features and packages of the SQL language specified in this part of ISO/IEC 9075 by an identifier and a short descriptive name. This taxonomy is used to specify conformance to the packages specified in this part of ISO/IEC 9075. The feature taxonomy may be used to develop other profiles involving the SQL language.
- 34) Annex G, “SQL/MED model”, is an informative Annex. It uses annotated diagrams to illustrate the more important concepts of the model of SQL/MED, including the relationships between the SQL-server, foreign-data wrappers, and foreign servers.

In the text of this part of ISO/IEC 9075, Clauses begin a new odd-numbered page, and in Clause 5, “Lexical elements”, through Clause 27, “Conformance”, Subclauses begin a new page. Any resulting blank space is not significant.

(Blank page)

Information technology — Database languages — SQL —

Part 9:
Management of External Data (SQL/MED)

1 Scope

This part of ISO/IEC 9075 defines extensions to Database Language SQL to support management of external data through the use of foreign-data wrappers and datalink types.

(Blank page)

2 Normative references

The following referenced documents are indispensable for the application of this document. For dated references, only the edition cited applies. For undated references, the latest edition of the referenced document (including any amendments) applies.

2.1 ISO/IEC JTC 1 standards

[Framework] ISO/IEC CD 9075-1:200n, *Information technology — Database languages — SQL — Part 1: Framework (SQL/Framework)*.

[Foundation] ISO/IEC CD 9075-2:200n, *Information technology — Database languages — SQL — Part 2: Foundation (SQL/Foundation)*.

[CLI] ISO/IEC CD 9075-3:200n, *Information technology — Database languages — SQL — Part 3: Call-Level Interface (SQL/CLI)*.

[Schemata] ISO/IEC CD 9075-11:200n, *Information technology — Database languages — SQL — Part 11: Information and Definition Schemas (SQL/Schemata)*.

2.2 Other international standards

[RFC2368] RFC 2368, *The mailto URL scheme*, R. Hoffman, L. Masinter, J. Zawinski, July, 1998.
<http://www.ietf.org/rfc/rfc2358.txt>

[RFC2396] RFC 2396, *Uniform Resource Identifiers (URI): Generic Syntax*, T. Berners-Lee, R. Fielding, L. Masinter, August, 1998
<http://www.ietf.org/rfc/rfc2396.txt>

[XML] *Extensible Markup Language (XML) Version 1.0 (second edition)*, Tim Bray, Jean Paoli, C. M. Sperberg-McQueen, and Eve Maler (editors)
<http://www.w3.org/TR/REC-xml>

(Blank page)

3 Definitions, notations, and conventions

3.1 Definitions

This Subclause modifies Subclause 3.1, “Definitions”, in ISO/IEC 9075-2.

3.1.1 Definitions taken from XML

For the purposes of this part of ISO/IEC 9075, the definitions of the following terms given in [XML] apply:

3.1.1.1 Valid XML document

3.1.1.2 XML document

3.1.1.3 XML document type declaration (also known as a DTD)

3.1.2 Definitions provided in Part 9

For the purposes of this part of ISO/IEC 9075, in addition to those definitions taken from other sources, the following definitions apply:

3.1.2.1 access token: An encrypted value returned under certain conditions by an SQL-server in combination with the File Reference of a datalink value. An access token is either a *read token* or a *write token*.

3.1.2.2 datalink: A value, of data type DATALINK, referencing some file that is not part of the SQL-environment. The file is assumed to be managed by some external file manager.

3.1.2.3 datalinker: An implementation-dependent component for controlling access and referential integrity to external files.

3.1.2.4 external data: Data that is not managed by an SQL-server involved in an SQL-session, but that is nevertheless accessible to that SQL-session.

3.1.2.5 foreign-data wrapper: A named collection of routines, invocable by the SQL-server, supporting the programming interface specified for such routines in this part of ISO/IEC 9075.

3.1.2.6 foreign server: A named server, external to the SQL-environment, but known to the SQL-server, that manages external data.

3.1.2.7 foreign server request: Denotes the statement that the SQL-server submits to the foreign-data wrapper.

3.1 Definitions

- 3.1.2.8 foreign table:** A named table whose rows are supplied when needed by some foreign server. The mechanism by which these rows are supplied is provided by a foreign-data wrapper. The data constituting a foreign table is not part of the SQL-environment.
- 3.1.2.9 integrity control option:** A link control option specifying the level of integrity of the link between a datalink and the file that it references.
- 3.1.2.10 link control:** A property of a column of data type DATALINK, specifying the extent to which the links between datalinks in that column and the files they reference are to be monitored (in various specific manners).
- 3.1.2.11 read permission option:** A link control option specifying how permission to read external files referenced by certain datalinks is determined.
- 3.1.2.12 recovery option:** A link control option specifying whether or not point in time recovery is required for the files referenced by certain datalinks.
- 3.1.2.13 routine mapping:** An implementation-defined mapping of an SQL-invoked routine to an equivalent concept maintained by a foreign server.
- 3.1.2.14 SQL/MED-implementation:** An SQL-implementation that processes SQL-statements that are possibly extended by the language defined in this part of ISO/IEC 9075. A *conforming SQL/MED-implementation* is an SQL/MED-implementation that satisfied the requirements for SQL/MED-implementations as defined in [Clause 27](#), “Conformance”.
- 3.1.2.15 unlink option:** A link control option specifying the action to be taken when certain sites occupied by datalinks are updated or deleted.
- 3.1.2.16 user mapping:** An implementation-defined mapping of an authorization identifier to an equivalent concept maintained by a foreign server.
- 3.1.2.17 write permission option:** A link control option specifying how permission to write files referenced by certain datalinks is determined.

4 Concepts

This Clause modifies Clause 4, “Concepts”, in ISO/IEC 9075-2.

4.1 Data types

This Subclause modifies Subclause 4.1, “Data types”, in ISO/IEC 9075-2.

4.1.1 Naming of predefined types

This Subclause modifies Subclause 4.1.2, “Naming of predefined types”, in ISO/IEC 9075-2.

Insert after 1st paragraph SQL defines a predefined data type named by the following <key word>: DATALINK.

Insert after 2nd paragraph For reference purposes, the data type DATALINK is referred to as a (or the) *datalink type*.

4.1.2 Comparison and ordering

This Subclause modifies Subclause 4.1.4, “Comparison and ordering”, in ISO/IEC 9075-2.

Augment the list in the 4th paragraph

— A type *T* is *DATALINK-ordered* if *T* is *S-ordered*, where *S* is the set of datalink types.

4.2 Foreign servers

A *foreign server* is a named server, external to the SQL-environment but known to the SQL-server, that manages external data. Such external data is manifested as SQL-data by use of a mechanism called a *foreign-data wrapper* (see Subclause 4.3, “Foreign-data wrappers”).

A *foreign server descriptor* is a catalog element, identified by a *foreign server name* and created by invoking a <foreign server definition>. A foreign server descriptor consists of:

- A foreign server name, identifying the foreign server locally to the SQL-server.
- The authorization identifier of the owner of the foreign server descriptor.
- The name of the foreign-data wrapper.

4.2 Foreign servers

- A generic options descriptor.
- Optionally, the foreign server type.
- Optionally, the foreign server version.

The possible values of server type and server version, and their meanings, are implementation-defined.

A foreign server descriptor is said to be *owned by* or to have been *created by* the current authorization identifier for the SQL-session when the <foreign server definition> was invoked.

A foreign server descriptor can be modified by an <alter foreign server statement> and destroyed by a <drop foreign server statement>.

A foreign server can be an *SQL-aware foreign server* or a *non-SQL-aware foreign server*. An SQL-aware foreign server is a foreign server that has the ability to process a subset of statements conforming to ISO/IEC 9075, particularly the statements comprising Feature E051, “Basic query specification”, in a standard-conforming manner. A non-SQL-aware foreign server is a foreign server that has no ability to process SQL language. If the foreign-data wrapper associated with a non-SQL-aware foreign server provides some (limited or conforming) ability to process SQL language, then the effect is that the foreign server can be treated as though it is an SQL-aware foreign server.

NOTE 1 — Some SQL-aware foreign servers may be, in fact, SQL-servers. However, because they are not in the same SQL-environment as the SQL-server responding to an SQL-client, they are managed only through foreign-data wrappers and are treated as foreign servers. Such foreign servers may concurrently respond to SQL-clients of their own; this does not change the relationships specified in this part of ISO/IEC 9075.

Some foreign servers, especially SQL-aware foreign servers, admit the concept of a schema and the concept of a table that are similar to SQL-schemas and to base tables, respectively. Such servers may (and SQL-aware foreign servers do) maintain schema information about those entities, such as the Information Schema and Definition Schema specified in ISO/IEC 9075-11.

If a foreign server maintains schema information about entities analogous to SQL-schemas and base tables, then execution of an <import foreign schema statement> retrieves information about the tables (either all or only some, as specified in the <import foreign schema statement>) associated with the named SQL-schema analog and effectively performs one or more <foreign table definition> statement executions.

If a foreign server does not maintain such information or does not admit the concept of a schema, then foreign tables managed by that server shall be specified by means of explicit <foreign table definition>s.

This International Standard does not specify the manner in which the SQL-server and the foreign-data wrapper interact to cause information about foreign tables to be retrieved by execution of an <import foreign schema statement>. In particular, no foreign-data wrapper interface routines are specified to support such interaction. Such interaction is implementation-dependent.

4.3 Foreign-data wrappers

A foreign-data wrapper is the mechanism by which the SQL-server accesses external data managed by foreign servers. Every foreign server is accessed through exactly one foreign-data wrapper, but one foreign-data wrapper can be used to access several different foreign servers. A foreign-data wrapper is made up of foreign-data wrapper interface routines and a set of routines written in a standard programming language. Foreign-data wrapper interface routines are used to access every foreign server whose descriptor includes the name of that

foreign-data wrapper. It is possible for a foreign-data wrapper to exist that is not used to access any foreign server.

A *foreign-data wrapper descriptor* is a catalog element, identified by a *foreign-data wrapper name* and created by invoking a <foreign-data wrapper definition>. A <foreign-data wrapper definition> specifies the foreign-data wrapper name, a library name that identifies a library containing the foreign-data wrapper interface routines, and the name of the language in which the foreign-data wrapper interface routines are written.

A foreign-data wrapper descriptor consists of:

- A foreign-data wrapper name.
- The authorization identifier of the owner of the foreign-data wrapper descriptor.
- The name of the language in which the foreign-data wrapper interface routines are written.
- A generic options descriptor.
- A library name.

A foreign-data wrapper descriptor can be modified by an <alter foreign-data wrapper statement> and destroyed by a <drop foreign-data wrapper statement>.

4.4 User mappings

A user mapping is an SQL-environment element, pairing an authorization identifier *U* or the special identifier PUBLIC, denoting all <authorization identifier>s in the SQL-environment, with a foreign server *FS*. It defines how to map *U* to an equivalent concept known to *FS* when a foreign table whose source is *FS* is to be accessed during an SQL-session when the current authorization identifier is *U*. The mapping is specified by generic options defined by the foreign-data wrapper.

A user mapping is defined by invoking a <user mapping definition>. Invocation of a <user mapping definition> results in the creation of a user mapping descriptor in the SQL-environment. A user mapping descriptor consists of:

- An authorization identifier.
- A foreign server name, identifying a foreign server descriptor.
- A generic options descriptor.

A user mapping descriptor can be modified by an <alter user mapping statement> and destroyed by a <drop user mapping statement>.

4.5 Routine mappings

A routine mapping is an SQL-environment element, pairing an SQL-invoked routine *SIR* with a foreign server *FS*. It defines how to map *SIR* to an equivalent concept known to *FS* when a foreign table *FT* whose source is *FS* is to be accessed and the foreign server request that includes *FT* also includes a reference to *SIR*. The mapping is specified by generic options defined by the foreign-data wrapper.

4.5 Routine mappings

A routine mapping is defined by invoking a <routine mapping definition>. Invocation of a <routine mapping definition> results in the creation of a routine mapping descriptor in the SQL-environment. A routine mapping descriptor consists of:

- The name of the routine mapping.
- The specific routine name of the SQL-invoked routine.
- A foreign server name, identifying a foreign server descriptor.
- A generic options descriptor.

A routine mapping descriptor can be modified by an <alter routine mapping statement> and destroyed by a <drop routine mapping statement>.

4.6 Generic options

Several of the objects used in connection with external data support the specification of *generic options*. These objects are foreign-data wrappers, foreign servers, foreign tables, columns of foreign tables, user mappings, and routine mappings. A generic option is an option name paired with an optional option value. Both the option name and the permissible ranges of option values of a generic option are defined by the foreign-data wrappers. A set of generic options is described by a generic options descriptor. A generic options descriptor is included in the descriptor of the object to which it pertains. The generic options are stored in the SQL-server for the foreign-data wrapper to retrieve when the foreign-data wrapper needs this information.

Generic options may be specified in either <foreign-data wrapper definition>, <foreign server definition>, <foreign table definition>, <user mapping definition>, <routine mapping definition>, <alter foreign-data wrapper statement>, <alter foreign server statement>, <alter foreign table statement>, <alter user mapping statement>, or <alter routine mapping statement>.

Generic options are specific to the object for which they are defined. For example, the generic options for a foreign table are most likely different from the generic options for a foreign server, in both option names and option values. Furthermore, generic options are highly dependent on the foreign-data wrapper that is used to access the external data. For example, the generic options for a foreign server that uses a foreign-data wrapper *A* might be totally different from the generic options specified for another foreign server that uses a foreign-data wrapper *B*. Even the fact that the option names of two generic options for two different foreign-data wrappers might be the same does not necessarily mean that the semantics and therefore the permissible ranges of option values are the same.

Since an SQL-server cannot anticipate the different kinds of foreign-data wrappers with which it is likely to deal, no generic option can ever be determined by the SQL-server or by this part of ISO/IEC 9075. Only a foreign-data wrapper can specify generic options for that foreign-data wrapper, or for a foreign server, a foreign table, a column of a foreign table, a user mapping, or a routine mapping for which it is used.

A *generic options descriptor* is either an empty list or a list consisting of one or more option names, each option name being paired with at most one option value.

4.7 Capabilities and options information

The SQL-server needs information from the foreign-data wrapper about the capabilities of the foreign-data wrapper itself, about the foreign server accessed through the foreign-data wrapper, and about certain schema elements (foreign tables and their columns, user mappings) managed by the foreign server. The SQL-server also needs information about options supported by the foreign-data wrapper, the foreign server, and certain schema elements. The SQL-server invokes the `GetOpts()` routine to request the capabilities and other information from a foreign-data wrapper.

The specific capabilities and other information of a foreign-data wrapper, a foreign server, or any schema element managed by a foreign server that are reported to the SQL-server in response to an invocation of `GetOpts()` are partly specified in this part of ISO/IEC 9075 and partly implementation-defined. In general, each capability or other piece of information that is reported corresponds to a generic option associated with the object being queried by the invocation.

The capabilities and other information is returned in a buffer whose contents may comprise an XML document or that may be returned in a format defined by the foreign-data wrapper. If the contents comprise an XML document, then it shall be a valid XML document, the format of which is specified by a Document Type Declaration (DTD) that is either internal to the XML document or external (requiring that it be available to the SQL-server in an implementation-defined manner).

NOTE 2 — This edition of this part of ISO/IEC 9075 specifies the use of a DTD. Future editions may specify the use of an XML Schema, either as an alternative to a DTD or instead of a DTD.

4.8 Datalinks

A datalink is a value of the DATALINK data type. A datalink references some file that is not part of the SQL-environment. The file is assumed to be managed by some external file manager. A datalink is conceptually represented by:

- File Reference: A character string forming a reference to an external file.
- SQL-Mediated Read Access Indication: A boolean value, where *True*, in datalink *DL* indicates that the referenced file, being linked to the SQL-environment, is accessible to be read only by use of the specially provided operations (see below) on *DL*.
- SQL-Mediated Write Access Indication: A boolean value, where *True*, in datalink *DL* indicates that the referenced file, being linked to the SQL-environment, is accessible to be modified only by use of the specially provided operations (see below) on *DL*.
- Write Token: An implementation-dependent value that represents an access token that is used to read or modify the File Reference. This value can be the null value.
- Construction Indication: A character string indicating how the datalink was constructed. Possible values are: NEWCOPY, PREVIOUSCOPY, and the null value.

The File Reference of a datalink is accessible by invoking operators defined in this part of ISO/IEC 9075. The character set of the File Reference, referred to as the *datalink character set* is implementation-defined.

The purpose of datalinks is to provide a mechanism to synchronize the integrity control, recovery, and access control of the files and the SQL-data associated with them. This part of ISO/IEC 9075 standardizes the way that an SQL-server is made aware of datalink values and how applications retrieve information about the files

4.8 Datalinks

identified by datalink values. The mechanisms that enable integrity control, recovery, and access control for the files represented by the datalink values are implementation-dependent. These mechanisms are collectively called the *datalinker*.

A file is *linked* to the SQL-environment whenever execution of an SQL-data change statement causes a value *DL1* that references that file to appear in some datalink column whose descriptor includes the link control FILE LINK CONTROL. If the read permission option included in the column descriptor is DB, then access to the referenced file is said to be *SQL-mediated*. This is indicated by setting the SQL-Mediated Read Access Indication of *DL1* to *True*, and *DL1* is said to be an *SQL-mediated datalink*. If the read permission option included in the column descriptor is not DB, then the SQL-Mediated Read Access Indication of *DL1* is set to *False*. If the write permission option included in the column descriptor is ADMIN, then this is indicated by setting the SQL-Mediated Write Access Indication of *DL1* to *True*. If the write permission option included in the column descriptor is not ADMIN, then the SQL-Mediated Write Access Indication of *DL1* is set to *False*.

Execution of an SQL-data change statement that causes a value *DL2* to appear in a datalink column defined with the link control NO LINK CONTROL does not cause any file to be linked to the SQL-environment.

A linked file cannot be renamed or deleted by any agency outside of the SQL-environment. A datalink value always references just one file. A file is *unlinked* from the SQL-environment whenever execution of an SQL-data change statement causes a datalink that references that file to be removed from some datalink column whose descriptor includes the link control FILE LINK CONTROL. The actions that occur when a datalink is removed from a column depend on the link control options that are specified in the column descriptor of that column. The file might be deleted, or the datalinker might return control of the file to the external data manager.

With the function provided by datalinks and the datalinker, it is possible to specify that access to the files should be mediated by the SQL-server rather than by the external data manager. When access to the files is mediated by an SQL-server, any request to access a file shall operate on an SQL-mediated datalink to obtain a character string with which to reference the file, using one of the operators provided for that purpose. This character string is constructed by combining the File Reference of a datalink value with an encrypted value called an *access token*. An access token is either a *read token* or a *write token*, depending on the function that is used to construct the character string. The generation of the access token and the method of combining it with the File Reference is implementation-dependent. When the application uses the returned character string value to access a file, the datalinker checks to see if the access token is *valid*. If it is valid, then the application is allowed to access the file pointed to by the File Reference. Every attempt by an application to access, without a valid access token, a file referenced by an SQL-mediated datalink is unsuccessful. The time at which a valid access token ceases to be valid is implementation-defined.

The content of an SQL-mediated file cannot be modified, unless the SQL-Mediated Write Access Indication of the datalink value *DL* referencing this file is *True*. After an application has modified the file, it uses a <datalink value constructor> that specifies either DLNEWCOPY or DLPREVIOUSCOPY to construct a new datalink value. This new datalink value is then used to update the site that contains *DL*.

NOTE 3 — Updating the site that contains a datalink in the manner described here is called “update-in-place”.

Datalinks are not comparable. A datalink is assignable only to sites of type DATALINK.

A datalink data type is described by a *datalink data type descriptor*. A datalink data type descriptor consists of the name DATALINK and the set of *link control options*:

- The link control (NO LINK CONTROL or FILE LINK CONTROL).
- The integrity control option (ALL, SELECTIVE, or NONE).
- The read permission option (FS or DB).

- The write permission option (FS, ADMIN, or BLOCKED). If the write permission option is ADMIN, then additionally the access token indication (either NOT REQUIRING TOKEN FOR UPDATE or REQUIRING TOKEN FOR UPDATE).
- The recovery option (NO or YES).
- The unlink option (RESTORE, DELETE, or NONE).

The meanings of the various link control options are:

- **NO LINK CONTROL:** Although every File Reference shall conform to the Format and Syntax Rules of [Subclause 8.1, “URL format”](#), it is permitted for there to be no file referenced by that File Reference. This option implies that the integrity control option is NONE, the read permission option is FS, the write permission option is FS, the recovery option is NO and the unlink option is NONE, and no explicit syntax to specify these options is permitted.
- **FILE LINK CONTROL:** Every File Reference shall reference an existing file. Further file control depends on the link control options.
- **INTEGRITY ALL:** Files referenced by File References cannot be deleted or renamed, except possibly through the use of operations on the column in question, invoked as part of some SQL-session.
- **INTEGRITY SELECTIVE:** Files referenced by File References can be deleted or renamed using operators provided by the file manager, unless a datalinker is installed in connection with the file manager.
- **INTEGRITY NONE:** Files referenced by File References can only be deleted or renamed using operators provided by the file manager. This option is not available if FILE LINK CONTROL is specified.
- **READ PERMISSION FS:** Permission to read files referenced by datalinks is determined by the file manager.
- **READ PERMISSION DB:** Datalinks of this type are SQL-Mediated. That is to say, permission to read files referenced by such datalinks is determined by the SQL-implementation.
- **WRITE PERMISSION FS:** Permission to write files referenced by datalinks is determined by the file manager.
- **WRITE PERMISSION ADMIN REQUIRING TOKEN FOR UPDATE:** Permission to write files referenced by datalinks is determined by the SQL-implementation and the datalinker. This option is only available if READ PERMISSION DB is also specified. If a site that was declared with this write permission is updated, then the access token used to open and modify the file is required to be contained in the file reference specified in the invocation of the functions DLNEWCOPY or DLPREVIOUSCOPY that yield the value with which the site is updated.
- **WRITE PERMISSION ADMIN NOT REQUIRING TOKEN FOR UPDATE:** Permission to write files referenced by datalinks is determined by the SQL-implementation and the datalinker. This option is only available if READ PERMISSION DB is also specified. If a site that was declared with this write permission is updated, then an access token is not required to be contained in the file reference specified in the invocation of the functions DLNEWCOPY or DLPREVIOUSCOPY that yield the value with which the site is updated.
- **WRITE PERMISSION BLOCKED:** Write access to files referenced by datalinks is not available. Updates can, however, arise indirectly through the use of some implementation-defined mechanism.
- **RECOVERY YES:** Enables *point in time recovery* of files referenced by datalinks.

NOTE 4 — “point in time recovery” is an implementation-defined mechanism that provides for recovery that is coordinated between the SQL-server and the files of external file manager referenced by datalinks.

4.8 Datalinks

- RECOVERY NO: Point in time recovery of files referenced by datalinks is disabled.
- ON UNLINK RESTORE: When a file referenced by a datalink is unlinked, the external file manager attempts to reinstate the ownership and permissions that existed when that file was linked.
- ON UNLINK DELETE: A file referenced by a datalink is deleted when it is unlinked.
- ON UNLINK NONE: When a file referenced by a datalink is unlinked, there is no change in the ownership and permissions occasioned by that unlinking.

Table 1, “Valid datalink file control options”, specifies what combinations of datalink file control options are allowed.

Table 1 — Valid datalink file control options

Integrity	Read permission	Write permission	Recovery	Unlink
ALL	FS	FS	NO	NONE
ALL	FS	BLOCKED	NO	RESTORE
ALL	FS	BLOCKED	YES	RESTORE
ALL	DB	BLOCKED	NO	RESTORE
ALL	DB	BLOCKED	NO	DELETE
ALL	DB	BLOCKED	YES	RESTORE
ALL	DB	BLOCKED	YES	DELETE
ALL	DB	ADMIN	NO	RESTORE
ALL	DB	ADMIN	NO	DELETE
ALL	DB	ADMIN	YES	RESTORE
ALL	DB	ADMIN	YES	DELETE
SELECTIVE	FS	FS	NO	NONE

NOTE 5 — In this table, the write permission option ADMIN is an abbreviation for both ADMIN REQUIRING TOKEN FOR UPDATE and ADMIN NOT REQUIRING TOKEN FOR UPDATE.

The default value of a site whose declared type is DATALINK is the null value. Datalinks are subject to certain restrictions. As a consequence of these restrictions, neither datalinks nor expressions whose declared type is DATALINK-ordered can appear in (among other places):

- <comparison predicate>.
- <general set function>.
- <group by clause>.

- <order by clause>.
- <unique constraint definition>.
- <referential constraint definition>.
- <select list> of a <query specification> that has a <set quantifier> of DISTINCT.
- <select list> of an operand of UNION, INTERSECT, and EXCEPT.
- Columns used for matching when forming a <joined table>.

The implementation-defined *maximum datalink length* determines the amount of space, in octets, that is allocated for:

- A host variable of data type DATALINK.
- An argument of declared type DATALINK to an invocation of an external routine.
- The value returned by an invocation of an external function whose result type is DATALINK.

The maximum datalink length constrains the values of expressions whose declared type is DATALINK such that every such value can be assigned to a host variable, substituted for a parameter to an external routine, or returned by an invocation of an external function.

4.8.1 Operations involving datalinks

4.8.1.1 Operators that operate on datalinks

<url complete expression> returns the File Reference of a given datalink, possibly combined with a read token.

<url complete for write expression> returns the File Reference of a given datalink, possibly combined with a write token.

<url complete only expression> returns the File Reference, excluding any access token, of a given datalink.

<url path expression> returns the path, including any read token, of the File Reference of a given datalink.

<url path for write expression> returns the path, including any write token, of the File Reference of a given datalink.

<url path only expression> returns the path, excluding any access token, of the File Reference of a given datalink.

<url scheme expression> returns the scheme of the File Reference of a given datalink.

<url server expression> returns the host of the File Reference of a given datalink.

NOTE 6 — “host”, “scheme”, and “path” are defined in Subclause 6.6, “<datalink value function>”.

4.8.1.2 Other operators involving datalinks

A <datalink value constructor> specifies either DLVALUE, DLNEWCOPY, or DLPREVIOUSCOPY. DLVALUE returns a datalink value, given only a File Reference, returns the corresponding datalink. DLNEWCOPY and DLPREVIOUSCOPY return a datalink value, given a File Reference and an indication of whether the File Reference includes a write token.

The datalink value returned by DLNEWCOPY indicates to the SQL-server that the content of the file, referenced by that datalink, is different (*i.e.*, the content has changed, but not the URL) from what was previously referenced by the datalink.

The datalink value returned by DLPREVIOUSCOPY indicates to the SQL-server that the content of the file might have changed, but the application is not interested in maintaining the changed file. The original file is restored in an implementation-dependent fashion.

4.9 Columns, fields, and attributes

This Subclause modifies Subclause 4.13, “Columns, fields, and attributes”, in ISO/IEC 9075-2.

Insert after 7th paragraph The term *constituent* is defined for values such that a value *V2* either is or is not a constituent of a value *V1*.

NOTE 7 — For example, the integer 2 and the character string 'one' are both constituents of the row value denoted by ROW (2 , 'one'). By contrast, the integer 3 is not a constituent of that row value.

V2 is an *immediate constituent* of *V1* if any of the following are true:

- *V1* is a value of some predefined data type or of some distinct type whose source type is some predefined data type and *V2* is identical to *V1*.
- *V1* is a value of some structured type *ST* and, for some attribute *A* of *ST*, *V2* is identical to *V1.A()*.
- *V1* is a value of some row type *RT* and, for some field *F* of *RT*, *V2* is identical to *V1.F*.
- *V1* is a value of some collection type *CT* and *V2* is an element of *V1*.

V2 is a constituent of *V1* if *V2* is an immediate constituent of *V1* or there is some value *V3* such that *V3* is an immediate constituent of *V1* and *V2* is a constituent of *V3*.

4.10 Tables

This Subclause modifies Subclause 4.14, “Tables”, in ISO/IEC 9075-2.

4.10.1 Types of tables

This Subclause modifies Subclause 4.14.2, “Types of tables”, in ISO/IEC 9075-2.

Replace 1st paragraph A table is either a base table, a derived table, a transient table, or a foreign table. A base table is either a persistent base table, a global temporary table, a created local temporary table, or a declared local temporary table.

4.10.2 Table descriptors

This Subclause modifies Subclause 4.14.3, “Table descriptors”, in ISO/IEC 9075-2.

Replace 1st paragraph A table is described by a table descriptor. A table descriptor is either a base table descriptor, a view descriptor, a derived table descriptor (for a derived table that is not a view), or a foreign table descriptor.

Insert this paragraph The data constituting a foreign table is not part of the SQL-environment. Instead, its rows are supplied when needed by some foreign server, known as the *source* of the foreign table. The mechanism by which these rows are supplied is provided by a *foreign-data wrapper* (see Subclause 4.3, “Foreign-data wrappers”). A foreign table descriptor describes a foreign table. In addition to the components of every table descriptor, a foreign table descriptor includes:

- The name of the foreign table.
- A foreign server name, identifying the descriptor of the foreign server that is the source of the foreign table.
- A generic options descriptor.
- An indication of whether the foreign table is updatable or not.

NOTE 8 — This part of ISO/IEC 9075 currently restricts foreign tables such that they are neither insertable-into nor updatable. Future versions of this part of ISO/IEC 9075 may relax these restrictions.

4.10.3 Relationships between tables

This Subclause modifies Subclause 4.14.4, “Relationships between tables”, in ISO/IEC 9075-2.

- **Replace 1st list item following 5th paragraph** If *TORQN* identifies a base table or a foreign table, or if *TORQN* is a <transition table name>, then *TORQN* has no generally underlying tables.

4.11 Functional dependencies

This Subclause modifies Subclause 4.18, “Functional dependencies”, in ISO/IEC 9075-2.

4.11.1 Overview of functional dependency rules and notations

This Subclause modifies Subclause 4.18.1, “Overview of functional dependency rules and notations”, in ISO/IEC 9075-2.

4.11 Functional dependencies

Replace 1st paragraph This Subclause defines *functional dependency* and specifies a minimal set of rules that a conforming implementation shall follow to determine functional dependencies and candidate keys in base tables, foreign tables, and <query expression>s.

4.11.2 Known functional dependencies in a foreign table

There are no rules in this part of ISO/IEC 9075 to determine known functional dependencies in a foreign table. However, implementation-defined rules may determine known functional dependencies, if any, in a foreign table.

4.12 SQL-schemas

This Subclause modifies Subclause 4.20, “SQL-schemas”, in ISO/IEC 9075-2.

Replace 5th paragraph Base tables, foreign tables, and views are identified by <table name>s. A <table name> consists of a <schema name> and an <identifier>. The <schema name> identifies the schema in which a persistent base table, foreign table, or view identified by the <table name> is defined. Base tables, foreign tables, and views defined in different schemas can have <identifier>s that are equal according to the General Rules of Subclause 8.2, “<comparison predicate>”, in ISO/IEC 9075-2.

4.13 SQL-statements

This Subclause modifies Subclause 4.33, “SQL-statements”, in ISO/IEC 9075-2.

4.13.1 SQL-statements classified by function

This Subclause modifies Subclause 4.33.2, “SQL-statements classified by function”, in ISO/IEC 9075-2.

4.13.1.1 SQL-schema statements

This Subclause modifies Subclause 4.33.2.1, “SQL-schema statements”, in ISO/IEC 9075-2.

Insert this paragraph The following are additional SQL-schema statements:

- <import foreign schema statement>
- <foreign table definition>
- <alter foreign table statement>
- <drop foreign table statement>

- <foreign server definition>
- <alter foreign server statement>
- <drop foreign server statement>
- <foreign-data wrapper definition>
- <alter foreign-data wrapper statement>
- <drop foreign-data wrapper statement>
- <user mapping definition>
- <alter user mapping statement>
- <drop user mapping statement>
- <routine mapping definition>
- <alter routine mapping statement>
- <drop routine mapping statement>

4.13.1.2 SQL-session statements

This Subclause modifies Subclause 4.33.2.7, “SQL-session statements”, in ISO/IEC 9075-2.

Insert this paragraph The following are additional SQL-session statements:

- <set passthrough statement>

4.14 Basic security model

This Subclause modifies Subclause 4.34, “Basic security model”, in ISO/IEC 9075-2.

4.14.1 Privileges

This Subclause modifies Subclause 4.34.2, “Privileges”, in ISO/IEC 9075-2.

Augment the list in the 1st paragraph

- foreign table
- foreign-data wrapper
- foreign server

NOTE 9 — Privileges granted on foreign tables are not privileges to use the data constituting foreign tables, but privileges to use the definitions of the foreign tables. The privileges to access the data constituting the foreign tables are enforced by the foreign server, based on the user mapping. Consequently, a request by an SQL-client to access external data may raise exceptions.

4.14 Basic security model

Augment the list in the 8th paragraph

- foreign-data wrapper
- foreign server

4.15 SQL-transactions

This Subclause modifies Subclause 4.35, “SQL-transactions”, in ISO/IEC 9075-2.

4.15.1 Properties of SQL-transactions

This Subclause modifies Subclause 4.35.3, “Properties of SQL-transactions”, in ISO/IEC 9075-2.

Augment 2nd paragraph Add foreign tables to the list of objects for which the term *read-only* applies.

4.16 SQL-sessions

This Subclause modifies Subclause 4.37, “SQL-sessions”, in ISO/IEC 9075-2.

4.16.1 SQL-session properties

This Subclause modifies Subclause 4.37.3, “SQL-session properties”, in ISO/IEC 9075-2.

Insert this paragraph At any time during an SQL-session, the SQL-server may obtain a WrapperEnvHandle for a foreign-data wrapper and an FSConnectionHandle for a foreign server.

Insert this paragraph The SQL-session context also comprises:

- Zero or more {foreign-data wrapper name : WrapperEnvHandle} pairs.
- Zero or more {foreign server name : FSConnectionHandle} pairs.
- A pass-through flag.
- A pass-through foreign server name, if any.
- Zero or more {<statement name> : ExecutionHandle} pairs.

Insert this paragraph At the end of every SQL-session, every FSConnection handle that is contained in the SQL-session context is freed.

Insert this paragraph At the end of every SQL-session, every WrapperEnv handle that is contained in the SQL-session context is freed.

Insert this paragraph An SQL-session has a pass-through flag that is initially set to *False* when the SQL-session is started. The successful execution of a <set passthrough statement> that contains a <foreign server name> changes the pass-through flag to *True*. An SQL-session whose pass-through flag is *True* additionally has a pass-through foreign server name. Every time a <set passthrough statement> is executed, all {<SQL statement name> : ExecutionHandle} pairs are removed from the current SQL-session context. Every time a <set passthrough statement> that contains a <foreign server name> *FSN* is successfully executed, the pass-through foreign server name included the current SQL-session context is set to *FSN*. Every time a <prepare statement> is executed after a <set passthrough statement> that contains a <foreign server name> has been executed successfully, an {<SQL statement name> : ExecutionHandle} pair is made part of the current SQL-session context. Every time a <deallocate prepared statement> is successfully executed after a <set passthrough statement> that identifies a <foreign server name> has been executed, the corresponding {<SQL statement name> : ExecutionHandle} pair is removed from the current SQL-session context. Every time a <set passthrough statement> that specifies 'OFF' is executed, the pass-through flag is set to *False* and the pass-through foreign server name is deleted from the current SQL-session context.

4.17 Foreign-data wrapper interface

A foreign-data wrapper interface consists of the signatures of the routines that make up a given foreign-data wrapper. These routines serve the following purposes:

- Allocate and deallocate resources.
- Control connections to foreign servers.
- Receive data from the SQL-server about the foreign server request to be executed at the foreign server.
- Send data from the foreign server to the SQL-server about the foreign server request that the foreign server is willing to execute.
- Initiate and terminate the execution of foreign server requests by the foreign server.

4.17.1 Handles

A *handle* is a value of INTEGER data type that identifies an allocated resource that provides session state information about a foreign server, a foreign-data wrapper, or a foreign server session of interest to connected components of that session. Handles presented as arguments to invocations of foreign-data wrapper interface routines enable the invoker to give or obtain the information they reference. The handle of a particular resource is allocated by the keeper of the state information — either the foreign-data wrapper or the SQL-server — to enable the SQL-server or the foreign-data wrapper, respectively, to access that state information. Although the declared type for a handle is INTEGER, its value has no meaning in any other context and should not be used as a numeric operand or modified in any way.

The following are the handles specified in the foreign-data wrapper interface, presented in approximately the order in which they are materialized in Table 2, “Sequence of actions during the execution of foreign server requests”. The operations that cause their creation and destruction are given in Table 2, “Sequence of actions during the execution of foreign server requests”.

- **WrapperEnv handle:** This handle is allocated by a foreign-data wrapper to reference information during the interaction with the SQL-server. It identifies an *allocated FDW-environment* and is allocated via a call

4.17 Foreign-data wrapper interface

from the SQL-server to the `AllocWrapperEnv()` routine. This handle shall be allocated before any foreign server requests are made to a foreign-data wrapper. It remains valid until the SQL-server invokes `FreeWrapperEnv(WH)`, where *WH* is the handle in question.

- **Server handle:** This handle is allocated by the SQL-server to reference a foreign server. A foreign-data wrapper uses this handle to obtain information about a foreign server to which it needs to connect. Routines associated with a server handle allow information to be obtained about such things as the server name, server type, server version, *etc.* This handle is allocated implicitly and presented by the SQL-server to a foreign-data wrapper by invoking `ConnectServer()`.
- **FSCONNECTION handle:** This handle is allocated by a foreign-data wrapper to reference information about a foreign server session. It is allocated via a call to the `ConnectServer()` routine. This handle shall be allocated before any foreign server requests to be executed during that foreign server session are presented to a foreign-data wrapper.
- **Query Context handle:** This handle is allocated by the foreign-data wrapper to reference information that spans multiple foreign server requests. The SQL-server uses it to indicate to the foreign-data wrapper that identical value expression handles in the same query context (denoted by the same Query Context handle) but in different foreign server requests (represented by different Request handles) represent identical value expressions. It is foreign-data wrapper implementation-dependent whether the foreign-data wrapper uses this information to re-use the previously evaluated value expression or whether the foreign-data wrapper re-evaluates the value expression. The handle remains valid until the SQL-server invokes `FreeQueryContext()`.
- **Request handle:** This handle is allocated by the SQL-server to reference a foreign server request that is to be executed by a foreign server. A request handle may reference a simple foreign server request, such as `SELECT * FROM T`, or it may reference a complex foreign server request that includes predicates, joins, ordering, *etc.* A request handle is used by the foreign-data wrapper to retrieve (for example) the names of foreign tables referenced in the from clause, the names of column references in the select list, *etc.*, using foreign-data wrapper interface SQL-server routines. This handle is allocated implicitly.
- **Table Reference handle:** This handle is allocated by the SQL-server to reference a <table reference> contained in the <from clause> of a <query specification>. This handle is allocated implicitly.
- **Value Expression handle:** This handle is allocated by the SQL-server to reference a <value expression> contained in a foreign server request. This handle is allocated implicitly.
- **Reply handle:** This handle is allocated by a foreign-data wrapper to reference the subset of foreign server requests it is capable of executing. This handle is allocated via a call during a foreign server session to the `InitRequest()` routine and remains valid in that foreign server session until it is the argument to an invocation of `FreeReplyHandle()`.
- **Execution handle:** This handle is allocated by a foreign-data wrapper. In decomposition mode, it is used to reference the information the foreign-data wrapper needs to process the foreign server request referenced by the corresponding reply handle and the information associated with the data resulting from the processing of the foreign server request. This handle is allocated via a call to the `InitRequest()` routine, which sets the associated PASSTHROUGH flag to *False*. In pass-through mode, this handle is used to reference the information that the foreign-data wrapper needs to process the foreign server request that is sent to the foreign server. This handle is allocated via a call to the `TransmitRequest()` routine, which sets the associated PASSTHROUGH flag to *True*.

NOTE 10 — “decomposition mode” and “pass-through mode” are defined in Subclause 4.17.3.5, “Decomposition and pass-through modes”.

- **Wrapper handle:** This handle is allocated implicitly by the SQL-server to reference the information about a foreign-data wrapper.
- **User handle:** This handle is allocated implicitly by the SQL-server to reference information about the user on whose behalf a connection to a foreign server is being made.
- **Descriptor handle:** This handle is allocated by either the SQL-server or a foreign-data wrapper to reference a foreign-data wrapper descriptor area.
- **Routine Mapping handle:** This handle is implicitly allocated by the SQL-server to reference an allocated routine mapping description.

4.17.2 Foreign server sessions

A *foreign server session* is the sequence of operations performed by a foreign-data wrapper on a particular `FSCONNECTION` handle during the existence of that handle.

A foreign server session on `FSCONNECTION` handle *FSCH* begins with the invocation of `ConnectServer ()` that brings *FSCH* into existence and ends with the invocation of `FreeFSCONNECTION (FSCH)`.

4.17.3 Foreign-data wrapper interface routines

The terms *foreign-data wrapper interface SQL-server routine* and *foreign-data wrapper interface wrapper routine* are used to distinguish routines provided by the SQL-server from routines provided by a foreign-data wrapper, respectively. A foreign-data wrapper interface routine that is both an SQL-server routine and a wrapper routine is referred to as a *foreign-data wrapper interface general routine*.

The foreign-data wrapper interface routines of a given implementation are either all functions or all procedures, the choice being implementation-defined. They are functions if their return codes are values returned by their invocations and they are procedures if their return codes are instead assigned to an output parameter named `ReturnCode`. The specific terms *foreign-data wrapper interface function* and *foreign-data wrapper interface procedure* are used when it is necessary to distinguish between the two kinds.

4.17.3.1 Handle routines

- **GetServerName:** This routine returns the name of a foreign server given a server handle.
- **GetServerType:** This routine returns the type of a foreign server given a server handle.
- **GetServerVersion:** This routine returns the version of a foreign server given a server handle.
- **GetNumServerOpts:** This routine returns the number of generic options associated with a foreign server given a server handle.
- **GetServerOpt:** This routine returns the generic option name and its value given a server handle and the position of the option in the options list.

4.17 Foreign-data wrapper interface

- **GetServerOptByName:** This routine returns the generic option value given a server handle and the name of the option.
- **GetNumTableRefElems:** This routine returns the number of <table reference>s in the <from clause> of a query given a request handle.
- **GetTableRefElem:** This routine returns the table reference handle of a <table reference> in the <from clause> of a query given a request handle and the position of the <table reference> in the <from clause>.
- **GetTableRefElemType:** This routine returns the “type” of a <table reference> given the table reference handle. The only possible return value is TABLE_NAME.
- **GetTableRefTableName:** This routine returns the table name given a table reference handle.
- **GetNumSelectElems:** This routine returns the number of <value expression>s in the <select list> of a <query specification> given a request handle.
- **GetSelectElem:** This routine returns the value expression handle of a <value expression> in the <select list> of a <query specification> given a request handle and the position of the <value expression> in the <select list>.
- **GetSelectElemType:** This routine returns the kind of a <value expression> given the value expression handle. Possible return values are COLUMN_NAME, OPERATOR, PARAMETER, and CONSTANT.
- **GetValExprColName:** This routine returns the name of the column, given a value expression handle.
- **GetNumReplyTableRefs:** This routine returns the number of table references from the original foreign server request that the foreign-data wrapper is capable of accessing, given a reply handle.
- **GetReplyTableRef:** This routine returns the number of the table reference in the original request that the foreign-data wrapper is capable of accessing, given a reply handle and a number that ranges from 1 (one) to the value returned by the `GetNumReplyTableRefs ()` routine.
- **GetNumReplySelectElems:** This routine returns the number of select list elements from the original foreign server request that the foreign-data wrapper is capable of accessing, given a reply handle.
- **GetReplySelectElem:** This routine returns the number of the select list element in the original foreign server request that the foreign-data wrapper is capable of accessing, given a reply handle and a number that ranges from 1 (one) to the value returned by the `GetNumReplySelectElems ()` routine.
- **GetNumReplyBoolVE:** This routine returns the number of <boolean value expression>s simply contained in the <where clause> of the original foreign server request that the foreign-data wrapper is capable of handling, given a reply handle.
- **GetReplyBoolVE:** This routine returns the number of a <boolean value expression> element from the <where clause> in the original foreign server request that the foreign-data wrapper is capable of handling, given a reply handle and a number that ranges from 1 (one) to the value returned by the `GetNumReplyBoolVE ()` routine.
- **GetReplyDistinct:** This routine returns information identifying whether the foreign-data wrapper is capable of providing distinct rows in the result set, given a reply handle.
- **GetReplyCardinality:** This routine returns an estimate of the cardinality of the result set associated with the reply, given a reply handle.
- **GetReplyFirstCost:** This routine returns a value that represents the estimated cost to retrieve the first row of the result set associated with the reply, given a reply handle. Larger values represent greater costs.

- **GetReplyExecCost:** This routine returns a value that represents the estimated cost to retrieve the result set associated with the reply, given a reply handle. Larger values represent greater costs.
- **GetReplyReExecCost:** This routine returns a value that represents the estimated cost to re-execute the reply, given a reply handle. Larger values represent greater costs.
- **GetNumReplyOrderBy:** This routine returns the number of columns that are used to order the result that the foreign-data wrapper is capable of handling, given a reply handle.
- **GetReplyOrderElem:** This routine returns the number of a <value expression> from the <select list> used to order the result in the original foreign server request that the foreign-data wrapper is capable of handling, given a reply handle and a number that ranges from 1 (one) to the value returned by the `GetNumReplyOrderBy()` routine.
- **GetNextReply:** This routine returns a new reply handle and execution handle for the original foreign server request, given a reply handle.
- **GetNumBoolVE:** This routine returns the number of <boolean value expression>s simply contained in the <where clause> of a <query specification>, given a request handle.
- **GetBoolVE:** This routine returns a handle for a <boolean value expression> from the <where clause> of a <query specification>, given a request handle and a number that ranges from 1 (one) to the value returned by the `GetNumBoolVE()` routine.
- **GetDistinct:** This routine returns information whether the query specifies DISTINCT or ALL, given a request handle.
- **GetNumOrderByElems:** This routine returns the number of columns that are used to order the result, given a request handle.
- **GetOrderByElem:** This routine returns a handle for a <value expression> used to order the result of a query, given a request handle and a number that ranges from 1 (one) to the value returned by the `GetNumOrderByElems()` routine.
- **GetValueExpKind:** This routine returns the kind of a <value expression>, given a value expression handle. Possible return values are COLUMN_NAME, OPERATOR, PARAMETER, CONSTANT.
- **GetNumChildren:** This routine returns the number of <value expression>s immediately contained in the containing <value expression>, given a value expression handle.
- **GetVEChild:** This routine returns a handle for a <value expression> immediately contained in the containing <value expression>, given a value expression handle and a number that ranges from 1 (one) to the value returned by the `GetNumChildren()` routine.
- **GetValueExpName:** This routine returns the name associated with a <value expression>, given a value expression handle.
- **GetValueExpTable:** This routine returns a table reference handle with which the table associated with the <value expression> is associated.
- **GetValueExpDesc:** This routine returns a handle for a value expression descriptor describing a <value expression>.
- **GetAuthorizationId:** This routine returns the authorization identifier associated with a user mapping, given a user handle.

4.17 Foreign-data wrapper interface

- **GetTableColOpt**: This routine returns the generic option name and its value, given a table reference handle, column name and the position of the option in the options list.
- **GetTableColOptByName**: This routine returns the generic option value, given a table reference handle, a column name and the name of the option.
- **GetTableOpt**: This routine returns the generic option name and its value, given a table reference handle and the position of the option in the options list.
- **GetTableOptByName**: This routine returns the generic option value, given a table reference handle and the name of the option.
- **GetTableServerName**: This routine returns the name of the foreign server associated with a foreign table, given a table reference handle.
- **GetNumTableColOpts**: This routine returns the number of generic options associated with a column of a foreign table, given a table reference handle and a column name.
- **GetNumTableOpts**: This routine returns the number of generic options associated with a foreign table, given a table reference handle.
- **GetNumUserOpts**: This routine returns the number of generic options associated with a user mapping, given a user handle.
- **GetNumWrapperOpts**: This routine returns the number of generic options associated with a foreign-data wrapper, given a wrapper handle.
- **GetUserOpt**: This routine returns the generic option name and its value, given a user handle and the position of the option in the options list.
- **GetUserOptByName**: This routine returns the generic option value, given a user handle and the name of the option.
- **GetWrapperLibraryName**: This routine returns the name of the library associated with a foreign-data wrapper, given a wrapper handle.
- **GetWrapperName**: This routine returns the name of a foreign-data wrapper, given a wrapper handle.
- **GetWrapperOpt**: This routine returns the generic option name and its value, given a wrapper handle and the position of the option in the options list.
- **GetWrapperOptByName**: This routine returns the generic option value, given a wrapper handle and the name of the option.
- **GetDescriptor**: This routine, given a descriptor handle and the identification of a descriptor area field, retrieves the value of the specified field from a descriptor area.
- **SetDescriptor**: This routine, given a descriptor handle, the identification of a descriptor area field, and a new value to be assigned to that field, sets the value of the specified field of a descriptor area.
- **GetSPDHandle**: This routine returns the SPDHandle given an ExecutionHandle.
- **GetSRDHandle**: This routine returns the SRDHandle given an ExecutionHandle.
- **GetTRDHandle**: This routine returns the TRDHandle given an TableReferenceHandle.
- **GetWPDHandle**: This routine returns the WPDHandle given an ExecutionHandle.

- **GetWRDHandle:** This routine returns the WRDHandle given an ExecutionHandle.
- **GetSQLString:** This routine returns a character string representation of the query that is associated with the request handle.
- **GetRoutineMapping:** This routine returns the routine mapping handle for an allocated routine mapping description, given a value expression handle.
- **GetRoutMapOptName:** This routine returns the generic option value, given the routine mapping handle and the name of the option.
- **GetRoutMapOpt:** This routine returns the generic option name and its value, given a routine mapping handle and the position of the option in the option list.
- **GetNumRoutMapOpts:** This routine returns the number of generic options associated with a routine mapping, given a routine mapping handle.

4.17.3.2 Initialization routines

- **AdvanceInitRequest:** This routine is used by the SQL-server to cause a foreign server request to be prepared. The routine has three input parameters: a previously allocated FSConnection handle, a previously allocated QueryContext handle, and a request handle that describes the foreign server request. The routine has two output parameters: a reply handle that describes how much of the foreign server request the foreign-data wrapper is willing to handle, and an execution handle to the state information the foreign-data wrapper needs to process the foreign server request and the data rows that will be returned. This routine uses the `InitRequest()` routine multiple times to generate multiple reply handle/execution handle pairs. Additional reply handle/execution handle pairs can be retrieved by the SQL-server using the `GetNextReply()` routine.
- **AllocDescriptor:** This routine is used by the foreign-data wrapper to request that the SQL-server allocate a foreign-data wrapper descriptor area for use in exchanging information about values required to execute a foreign server request or values expected to be returned from an execution of a foreign server request.
- **AllocQueryContext:** This routine is used by the SQL-server to retrieve a Query Context handle that the SQL-server will use to indicate to the foreign-data wrapper that identical Value Expression handles in different foreign server requests refer to identical value expressions.
- **AllocWrapperEnv:** This routine is used by the SQL-server to allow the foreign-data wrapper to perform any initialization steps and allocate and initialize any necessary global data structures. It has a single input parameter, a WrapperHandle, that describes the information about the foreign-data wrapper maintained by the SQL-server, and a single output parameter, a WrapperEnv handle, which is a handle to the foreign-data wrapper's newly initialized global data structures.
- **ConnectServer:** This routine is used by the SQL-server to request access to a foreign server, and allows the foreign-data wrapper associated with that foreign server to establish a connection (if necessary) and set up any required state information. ConnectServer has three input parameters: a previously allocated WrapperEnv handle, a server handle that describes the foreign server for which the SQL-server is requesting a connection, and a UserHandle that describes the user mapping maintained by the SQL-server. The routine has one output parameter, the newly allocated FSConnection handle for the foreign server.
- **GetOpts:** This routine is used by the SQL-server to request that the foreign-data wrapper return information about the capabilities and other aspects of the foreign-data wrapper, the foreign server, some foreign table

4.17 Foreign-data wrapper interface

at the foreign server, or some foreign column of some foreign table at the foreign server. This routine is invoked by the SQL-server, and executed by the foreign-data wrapper, whenever the SQL-server requires information about options supported by the foreign-data wrapper and the foreign server. It is thus invoked under implementation-dependent circumstances.

- **InitRequest:** This routine is used to generate a reply handle and an execution handle for a given foreign server request. The routine has two input parameters: a previously allocated FSConnection handle, and a request handle that describes the foreign server request. The routine has two output parameters: a reply handle that describes how much of the foreign server request the foreign-data wrapper is willing to handle, and an execution handle to the state information the foreign-data wrapper needs to process the foreign server request and the data rows that will be returned.

4.17.3.3 Access routines

- **Open:** This routine is used by the SQL-server to allow the foreign-data wrapper to allocate any resources necessary to perform the operations represented by the ExecutionHandle (and described by a ReplyHandle previously returned by an invocation of either AdvanceInitRequest() or GetNextReply()). The routine has one input parameter: a previously allocated ExecutionHandle.
- **Iterate:** This routine is used by the SQL-server to iteratively retrieve data from a foreign-data wrapper. The routine has one input parameter, a previously allocated ExecutionHandle. As a result of this call, the foreign-data wrapper will associate the row with the ExecutionHandle. The SQL-server may invoke this routine until all data is returned.
- **ReOpen:** This routine may be used by the SQL-server to allow a foreign-data wrapper to re-initialize any resources necessary to re-execute the operations represented by the ExecutionHandle (and described by a ReplyHandle previously returned by either the AdvanceInitRequest() routine or the GetNextReply() routine). This routine allows an SQL-server to re-execute the operations associated with an ExecutionHandle multiple times, for example, if the work to be done by the foreign-data wrapper represents the inner node of a join being processed by the SQL-server. The routine has one input parameter: a previously allocated ExecutionHandle.
- **Close:** This routine is used by the SQL-server to allow a foreign-data wrapper to free any resources that had been allocated to perform the operations represented by the ExecutionHandle. The SQL-server invokes this routine after it is done processing a foreign server request that initiated the communication with the foreign-data wrapper. The routine has one input parameter: a previously allocated ExecutionHandle.
- **GetStatistics:** This routine is used by the SQL-server to request statistics, if any, related to the foreign server request previously sent to the foreign-data wrapper. Such statistics are entirely implementation-defined in nature. This routine is invoked by the SQL-server, and executed by the foreign-data wrapper, whenever the SQL-server requires statistics that may be provided by the foreign-data wrapper and the foreign server. It is thus invoked under implementation-dependent circumstances.
- **TransmitRequest:** This routine is used by the SQL-server to transmit a foreign server request in the native language of the foreign server to the foreign server in pass-through mode. The foreign server analyzes the transmitted foreign server request and returns information about that foreign server request to the SQL-server. This information includes: Whether the foreign server request requires one or more input values in order to be executed; and whether the foreign server request returns one or more result values upon execution. This information is associated with the descriptors attached to the execution handle that is the output parameter of this routine. This routine has three input parameters: a previously allocated FSConnection handle, a string containing the foreign server request, and an integer indicating the string length.

4.17.3.4 Termination routines

- **FreeDescriptor:** This routine is used by the foreign-data wrapper to request that the SQL-server deallocate a foreign-data wrapper descriptor area and to free the memory and other resources used by that descriptor.
- **FreeExecutionHandle:** This routine is used by the SQL-server to allow the foreign-data wrapper to free the resources associated with an ExecutionHandle after the SQL-server has determined that it no longer needs the information encapsulated by the ExecutionHandle. This routine has one input parameter, a previously allocated ExecutionHandle.
- **FreeFSConnection:** This routine is used by the SQL-server to terminate a connection to a foreign server. It allows the foreign-data wrapper to disconnect from the foreign server and to free any resources associated with the connection, such as the FSConnection handle. It has one input parameter: a previously allocated FSConnection handle.
- **FreeQueryContext:** This routine is used by the SQL-server to allow the foreign-data wrapper to free all resources it may have associated with a Query Context handle. This routine has one input parameter, a previously allocated Query Context handle.
- **FreeReplyHandle:** This routine is used by the SQL-server to allow the foreign-data wrapper to free the resources associated with a ReplyHandle after the SQL-server has determined that it no longer needs the information encapsulated by the ReplyHandle. This routine has one input parameter, a previously allocated ReplyHandle.
- **FreeWrapperEnv:** This routine is used by the SQL-server to terminate communication with a foreign-data wrapper. It allows the foreign-data wrapper to free any global resources it had allocated, such as the WrapperEnv handle. The routine has one input parameter, a previously allocated WrapperEnv handle.

4.17.3.5 Decomposition and pass-through modes

Depending on whether the pass-through flag in the current SQL-session context is set to *True* or *False*, the SQL-server is said to be either in *pass-through mode* or *decomposition mode*. When the SQL-server is in decomposition mode, the SQL-server analyzes the SQL-client request and invokes the `AdvanceInitRequest()` routine to communicate foreign server request to the foreign-data wrapper. When the SQL-server is in pass-through mode, the SQL-server does not analyze the SQL-client request and invokes the `TransmitRequest()` routine to communicate foreign server request to the foreign-data wrapper.

4.17.3.6 Sequence of actions during the execution of foreign server requests

For decomposition mode, Table 2, “Sequence of actions during the execution of foreign server requests”, shows the sequence of actions as described by the General Rules of Subclause 7.1, “<table reference>”, when a foreign table is identified by the <table name> simply contained in the <table reference>.

For pass-through mode, Table 2, “Sequence of actions during the execution of foreign server requests”, shows the sequence of actions that is likely to occur when an SQL-client requests the preparation and execution of statements using dynamic SQL.

Table 2 — Sequence of actions during the execution of foreign server requests

Step	SQL-server		Flow	Foreign-data wrapper	
	Decomposition	Pass-through		Decomposition	Pass-through
1	Receives a query from SQL-client that involves data from a foreign table in a <table reference>. Determines relationship of foreign table → foreign server → foreign-data wrapper.	Receives from the SQL-client a statement to be executed in pass-through mode that involves one foreign server. Determines relationship of the foreign server to the foreign-data wrapper.			
2	Creates a WrapperHandle and associates information about the foreign-data wrapper with that handle.				
3	Invokes the AllocWrapperEnv (WrapperHandle, WrapperEnvHandle) routine to initialize the foreign data wrapper.		⇒		
4			⇐	Invokes the Get... (WrapperHandle, ...) routines in the SQL-server to retrieve information about the foreign-data wrapper that the SQL-server has stored in its Information Schema.	
NOTE 11 — This information is provided in the <foreign-data wrapper definition>.					
5	Executes the Get... (WrapperHandle, ...) routines as requested from the foreign-data wrapper.		⇒		
6				Allocates global data structures associated with the wrapper and associates them with the WrapperEnvHandle and performs any initialization required.	
7	Frees the WrapperHandle .				
NOTE 12 — If the current SQL-session context already includes a {foreign-data wrapper name : WrapperEnvHandle} pair that could be used, then steps 2 through 7 are optional.					
8	Creates a ServerHandle and associates information about the foreign server with that handle.				

Step	SQL-server		Flow	Foreign-data wrapper	
	Decomposition	Pass-through		Decomposition	Pass-through
9	Creates a UserHandle and associates information about the current user with that handle.				
10	Invokes the ConnectServer (WrapperEnvironmentHandle, ServerHandle, UserHandle, FSConnectionHandle) routine in the foreign-data wrapper to establish a connection to the foreign server that contains some of the data required to process the SQL-server client's query.		⇒		
11			⇐	Invokes the Get... (ServerHandle, ...) routines in the SQL-Server to retrieve all information about the foreign server that the SQL-server has stored in its Information Schema.	
NOTE 13 — This information is provided in the <foreign server definition>.					
12	Executes the Get... (ServerHandle, ...) routines as requested from the foreign data wrapper.		⇒		
13			⇐	Invokes the Get... (UserHandle, ...) routines in the SQL-Server to retrieve all information about the user that the SQL-server has stored in its Information Schema.	
NOTE 14 — This information is provided in the <user mapping definition>.					
14	Executes the Get... (UserHandle, ...) routines as requested from the foreign data wrapper.		⇒		
15				Allocates global data structures associated with the foreign server and associates them with a FSConnectionHandle , establishes a connection to the foreign server, and performs any initialization required.	
16	Frees the ServerHandle .				
17	Frees the UserHandle .				
NOTE 15 — If the current SQL-session context already includes a {foreign server name : FSConnectionHandle} pair that could be used, then steps 8 through 17 are optional.					

CD ISO/IEC 9075-9:2007 (E)
 4.17 Foreign-data wrapper interface

Step	SQL-server		Flow	Foreign-data wrapper	
	Decomposition	Pass-through		Decomposition	Pass-through
18	Invokes the Alloc-QueryContext() routine in the foreign-data wrapper to obtain a QueryContextHandle .		⇒		
19				Allocates data structures to utilize the information about the query context and associates them with the QueryContextHandle .	
20	Creates a RequestHandle and associates with it the information about the part of query that could be handled by the foreign-data wrapper.				
21	Creates as many TableReferenceHandles as are needed and associates with each of them the information about a particular <table reference>.				
22	Creates a TableReferenceDescriptor (TRD) for the result of the <query specification> described by the RequestHandle , and sets all the fields with details about each of the columns.				

Step	SQL-server		Flow	Foreign-data wrapper	
	Decomposition	Pass-through		Decomposition	Pass-through
23	Creates a Wrapper-ParameterDescriptor (WPD) to describe the <dynamic parameter specification>s in the <query specification> described by the RequestHandle , and sets all the fields with details about each of the <dynamic parameter specification>s.				
24	Creates as many ValueExpression-Handles as are needed and associates with each of them the information about a particular <value expression> in the <select list> and <where clause>, respectively.				
25	Invokes the AdvanceInitRequest (FSConnectionHandle, RequestHandle, ReplyHandle, ExecutionHandle, QueryContextHandle) routine in the foreign-data wrapper to find out how much of the request the foreign server can actually process.	Invokes the TransmitRequest (FSConnectionHandle, RequestString, StringLength, ExecutionHandle) routine to allow the foreign-data wrapper and the foreign server to analyze the foreign server request.	⇒		

CD ISO/IEC 9075-9:2007 (E)
 4.17 Foreign-data wrapper interface

Step	SQL-server		Flow	Foreign-data wrapper	
	Decomposition	Pass-through		Decomposition	Pass-through
26			←	Invokes the Get... (RequestHandle, ...) , GetTRDHandle (TableReferenceHandle) , GetDescriptor (TRD) , Get... (TableReferenceHandle, ...) , and Get... (ValueExpressionHandle, ...) routines in the SQL-server to examine the SQL-server's request and to determine how much of the request the foreign-data wrapper can handle.	Executes the TransmitRequest () routine.
NOTE 16 — The foreign-data wrapper could invoke the GetSQLString (RequestHandle, StringFormat, SQLString, BufferLength, StringLength) routine in the SQL-server to examine the foreign server request and to determine how much of the foreign server request the foreign-data wrapper can handle, instead of the Get... (RequestHandle, ...) , Get... (TableReferenceHandle, ...) , Get... (ValueExpressionHandle, ...) , GetTRDHandle (TableReferenceHandle) , and GetDescriptor (TRD) routines.					
27	Executes the Get... (RequestHandle, ...) , GetTRDHandle (TableReferenceHandle) , GetDescriptor (TRD) , Get... (TableReferenceHandle, ...) , and Get... (ValueExpressionHandle, ...) routines as requested by the foreign-data wrapper.		⇒		
NOTE 17 — If the foreign-data wrapper invoked the GetSQLString (RequestHandle, StringFormat, SQLString, BufferLength, StringLength) routine, then this routine is executed instead of the Get... (RequestHandle, ...) , Get... (TableReferenceHandle, ...) , Get... (ValueExpressionHandle, ...) , GetTRDHandle (TableReferenceHandle) , and GetDescriptor (TRD) routines.					

Step	SQL-server		Flow	Foreign-data wrapper	
	Decomposition	Pass-through		Decomposition	Pass-through
28				Creates a ReplyHandle and associates with it the information about the part of query that could actually be handled by the foreign-data wrapper.	
29			⇐	Creates an ExecutionHandle and associates with it the information about the actual execution plan.	
30			⇐	Invokes the AllocDescriptor () routine to create two descriptors (SRD and SPD) and associates both of them with the ExecutionHandle . Initializes the descriptors with default values wherever applicable.	Invokes the AllocDescriptor () routine to create two descriptors (WRD and SRD) to describe the columns of the result table and associates both of them with the ExecutionHandle . Initializes both the descriptors with default values wherever applicable. Sets the fields in the WRD to correspond to the result columns associated with the ExecutionHandle .
31	Executes the AllocDescriptor () routine as requested by the foreign-data wrapper.		⇒		

CD ISO/IEC 9075-9:2007 (E)
 4.17 Foreign-data wrapper interface

Step	SQL-server		Flow	Foreign-data wrapper	
	Decomposition	Pass-through		Decomposition	Pass-through
32			←		Invokes the AllocDescriptor () routine to create two descriptors, WPD and SPD, to describe <dynamic parameter specification>s. Associates both of them with the ExecutionHandle . Initializes both the descriptors with default values wherever applicable. Sets the fields in the WPD to correspond to the dynamic parameters associated with the ExecutionHandle .
33		Executes the AllocDescriptor () routine as requested by the foreign-data wrapper.	⇒		
34				Repeats steps 25 through 34 to create multiple ReplyHandle / ExecutionHandle pairs for the same foreign server request.	
NOTE 18 — Step 34 is optional.					
35	Invokes the Get...(ReplyHandle, ...) routines in the foreign-data wrapper to incorporate the work that a wrapper can do into the execution plan for the SQL-server client's query.		⇒		

Step	SQL-server		Flow	Foreign-data wrapper	
	Decomposition	Pass-through		Decomposition	Pass-through
36			⇐	Executes the Get...(ReplyHandle, ...) routines as requested by the SQL-server.	
37	Invokes the GetNextReply() routine to retrieve another ReplyHandle for the same foreign server request		⇒		
38			⇐	Executes the GetNextReply() routine and returns a ReplyHandle and ExecutionHandle .	
39	Repeats steps 35 — 39.				
NOTE 19 — Steps 37 through 39 are optional.					
40	Invokes the FreeReplyHandle (ReplyHandle) routine in the foreign-data wrapper to indicate that the ReplyHandle is no longer required.		⇒		
41				Frees resources associated with ReplyHandle .	
42	Repeats steps 20 — 42.				
NOTE 20 — Step 42 is optional.					

CD ISO/IEC 9075-9:2007 (E)
 4.17 Foreign-data wrapper interface

Step	SQL-server		Flow	Foreign-data wrapper	
	Decomposition	Pass-through		Decomposition	Pass-through
43	Invokes the GetSRD-Handle (ExecutionHandle) routine to get the SRD.	Invokes the GetWRDHandle (ExecutionHandle) and GetSRDHandle (ExecutionHandle) routines to get the WRD and the SRD, respectively.	⇒		
44			⇐	Executes the GetSRDHandle (ExecutionHandle) routine as requested by the SQL-server.	Executes the GetWRDHandle (ExecutionHandle) and GetSRDHandle (ExecutionHandle) routines as requested by the SQL-server.
45		Invokes the GetDescriptor (WRD) routine multiple times to get all the information associated with WRD.			
46	Invokes the SetDescriptor (SRD) routine multiple times to populate appropriate fields in SRD.				
NOTE 21 — In pass-through mode, SetDescriptor (SRD) will only be invoked if results are returned by the foreign-data server.					
47	Invokes the GetSPDHandle (ExecutionHandle) routine to get the SPD.	Invokes the GetWPDHandle (ExecutionHandle) and GetSPDHandle (ExecutionHandle) routines to get the WPD and SPD, respectively.	⇒		
48			⇒	Executes the GetSPDHandle (ExecutionHandle) routine as requested by the SQL-server.	Executes the GetWPDHandle (ExecutionHandle) and GetSPDHandle (ExecutionHandle) routines as requested by the SQL-server.

Step	SQL-server		Flow	Foreign-data wrapper	
	Decomposition	Pass-through		Decomposition	Pass-through
49		Invokes GetDescriptor (WPD) multiple times to obtain the information associated with WPD.			
50	If there are any dynamic parameters present, invokes SetDescriptor (SPD) multiple times to populate appropriate fields in SPD.		⇒		
51	Frees the RequestHandle .				
52	Frees each of the TableReferenceHandles .				
53	Frees each of the ValueExpressionHandles .				
54	Invokes the Open (ExecutionHandle) routine in the foreign-data wrapper to initiate the execution of the foreign server request in the foreign-data wrapper.		⇒		
55			⇐	Executes the Open (ExecutionHandle) routine as requested by the SQL-server.	
56	Invokes the Iterate (ExecutionHandle) routine in the foreign-data wrapper to retrieve a row.		⇒		
57			⇐	Performs the work needed to retrieve the next row from the foreign server and associates it with the ExecutionHandle .	
58	Repeats steps 56 through 57 until all data is retrieved.		⇔		
NOTE 22 — In pass-through mode, steps 56 through 58 are executed only if the foreign-data wrapper returns a set of rows.					

CD ISO/IEC 9075-9:2007 (E)
 4.17 Foreign-data wrapper interface

Step	SQL-server		Flow	Foreign-data wrapper	
	Decomposition	Pass-through		Decomposition	Pass-through
59	Optional: If the work performed by the wrapper needs to be repeated, the SQL-server may choose to invoke ReOpen (ExecutionHandle) routine in the foreign-data wrapper to allow the wrapper to prepare to re-execute the query.		⇒		
60				Optional: Executes the ReOpen (ExecutionHandle) routine as requested by the SQL-server to performs the steps necessary to reuse the resources allocated in the Open () call in order to re-execute. In the worst case, it may need to redo everything done in the Open () call. In the average case, it may only need to reset counters, cursors, <i>etc.</i>	
61	Completes the work necessary to answer the SQL-client's query. As a result, invokes Close (ExecutionHandle) routine in the foreign-data wrapper.	Completes the work necessary to answer the SQL-client's statement in pass-through mode. Possibly invokes the Close (ExecutionHandle) routine in the foreign-data wrapper.	⇒		
62				Executes the Close (ExecutionHandle) routine as requested by the SQL-server.	

Step	SQL-server		Flow	Foreign-data wrapper	
	Decomposition	Pass-through		Decomposition	Pass-through
63	Invokes FreeExecutionHandle (ExecutionHandle) routine in the foreign-data wrapper.		⇒		
64				Frees resources associated with ExecutionHandle .	
65			⇐	Invokes the FreeDescriptor () routine with the SRDHandle as the input argument.	Invokes the FreeDescriptor () routine four times with the SRDHandle , SPDHandle , WRDHandle , and WPDHandle , respectively, as the input arguments.
66	Executes the FreeDescriptor () routine as requested by the foreign-data wrapper.				
67	Invokes the FreeFSConnection (FSConnectionHandle) routine in the foreign-data wrapper.		⇒		
68				Frees resources associated with FSConnectionHandle .	
NOTE 23 — Steps 67 and 68 are optional, if the SQL-server wants to reuse the FSConnectionHandle.					
69	Invokes FreeWrapperEnv (WrapperEnvHandle) routine in the foreign-data wrapper.		⇒		
70				Frees resources associated with WrapperEnvHandle .	
NOTE 24 — Steps 69 and 70 are optional, if the SQL-server wants to reuse the WrapperEnvHandle.					

4.17.4 Return codes

The execution of a foreign-data wrapper interface routine causes one or more conditions to be raised. The status of the execution is indicated by a code that is returned either as the result of invoking a foreign-data wrapper interface function or as the value of the **ReturnCode** argument resulting from invoking a foreign-data wrapper interface procedure. The values and meanings of the return codes are as follows. If more than one return code is possible, then the one appearing later in the list is the one returned.

4.17 Foreign-data wrapper interface

NOTE 25 — Foreign-data wrapper functions and foreign-data wrapper procedures are defined in Subclause 22.1, “<foreign-data wrapper interface routine>”.

- A value of 0 (zero) indicates **Success**. The foreign-data wrapper interface routine executed successfully.
- A value of 1 (one) indicates **Success with information**. The foreign-data wrapper interface routine executed successfully but a completion condition was raised: *warning*.
- A value of 100 indicates **No data found**. The foreign-data wrapper interface routine executed successfully but a completion condition was raised: *no data*.
- A value of -1 indicates **Error**. The foreign-data wrapper interface routine did not execute successfully. An exception condition other than *FDW-specific condition — invalid handle* was raised.
- A value of -2 indicates **Invalid handle**. The foreign-data wrapper interface routine did not execute successfully because an exception condition was raised: *FDW-specific condition — invalid handle*.

If the foreign-data wrapper interface routine did not execute successfully, then the values of all output arguments are implementation-dependent unless explicitly defined by this part of ISO/IEC 9075.

In addition to providing the return code, for all foreign-data wrapper interface routines other than `GetDiagnostics()`, the implementation records information about completion conditions and about exception conditions raised other than *FDW-specific condition — invalid handle* in the diagnostics area associated with the resource being utilized.

The resource being utilized by a routine is the resource identified by its input handle. In case of routines that have multiple input handles, the resource being utilized is deemed to be the one identified by the handle that comes first in the parameter list, with one exception: in the case of `AllocWrapperEnv()` routine, diagnostics are returned on the output parameter, `WrapperEnvHandle`, provided an allocated FDW-environment is successfully created; otherwise, no diagnostics are returned.

4.17.5 Foreign-data wrapper diagnostics areas

Each diagnostics area consists of header fields that contain general information relating to the routine that was executed and zero or more status records containing information about individual conditions that occurred during the execution of the foreign-data wrapper interface routine. A condition that causes a status record to be generated is referred to as a status condition.

At the beginning of the execution of any foreign-data wrapper interface routine other than `GetDiagnostics()`, the diagnostics area for the resource being utilized is emptied. If the execution of such a routine does not result in the exception condition being raised: *FDW-specific condition — invalid handle*, then:

- Header information is generated in the diagnostics area.
- If the routine's return code indicates **Success**, then no status records are generated.
- If the routine's return code indicates **Success with information** or **Error**, then one or more status records are generated.
- If the routine's return code indicates **No data found**, then no status record is generated corresponding to SQLSTATE value '02000' but there may be status records generated corresponding to SQLSTATE value '02nnn', where 'nnn' is an implementation-defined subclass value.

Status records in the diagnostics area are placed in an order that is implementation-dependent except that:

- For the purpose of choosing the first status record, status records corresponding to transaction rollback have precedence over status records corresponding to other exceptions, which in turn have precedence over status records corresponding to the completion condition *no data*, which in turn have precedence over status records corresponding to the completion condition *warning*.
- Apart from any status records corresponding to an implementation-specified *no data*, any status record corresponding to an implementation-specified condition that duplicates, in whole or in part, a condition defined in this part of ISO/IEC 9075 shall not be the first status record.

The `GetDiagnostics()` routine retrieves information from a diagnostics area. The SQL-server or foreign-data wrapper identifies which diagnostics area is to be accessed by providing the handle of the relevant resource as an input argument. The `GetDiagnostics()` routine returns a result code but does not modify the identified diagnostics area.

A foreign-data wrapper diagnostics area consists of the fields specified in Table 3, “Fields used in foreign-data wrapper diagnostics areas”.

Table 3 — Fields used in foreign-data wrapper diagnostics areas

Field	Data type
MORE	INTEGER
NUMBER	INTEGER
RETURNCODE	SMALLINT
Implementation-defined header field	Implementation-defined
CLASS_ORIGIN	CHARACTER VARYING (<i>LI</i>) [†]
MESSAGE_LENGTH	INTEGER
MESSAGE_OCTET_LENGTH	INTEGER
MESSAGE_TEXT	CHARACTER VARYING (<i>LI</i>) [†]
NATIVE_CODE	INTEGER
SQLSTATE	CHARACTER (5)
SUBCLASS_ORIGIN	CHARACTER VARYING (<i>LI</i>) [†]
Implementation-defined status field	Implementation-defined
[†] Where <i>LI</i> is an implementation-defined integer not less than 254.	

All diagnostics area fields in other parts of ISO/IEC 9075 that are not included in this table are not applicable to foreign-data wrapper interface routines.

4.17.6 Null pointers

If the standard programming language of the caller of a routine supports pointers, then the caller may provide a zero-valued pointer, referred to as a *null pointer*, in the following circumstances:

- In lieu of an output argument that is to receive the length of a returned character string. This indicates that the caller wishes to prohibit the return of this information.
- In lieu of other output arguments where specifically allowed by this part of ISO/IEC 9075. This indicates that the caller wishes to prohibit the return of this information.
- In lieu of input arguments where specifically allowed by this part of ISO/IEC 9075. The semantics of such a specification depend on the context.

If the caller provides a null pointer in any other circumstances, then an exception condition is raised: *FDW-specific condition — invalid use of null pointer*.

4.17.7 Foreign-data wrapper descriptor areas

A foreign-data wrapper descriptor area provides an interface for a description of values required for the execution of a foreign server request in either decomposition mode or in pass-through mode by a foreign-data wrapper and for a description of values resulting from such an execution.

Each foreign-data wrapper descriptor area comprises header fields and zero or more foreign-data wrapper item descriptor areas. The header and item descriptor area fields are specified in Table 4, “Fields in foreign-data wrapper descriptor areas”. The header fields include a COUNT field that indicates the number of item descriptor areas.

Some host languages are able to access host variables whose addresses are stored in an item descriptor field named DATA_POINTER in a foreign-data wrapper descriptor area. Such languages are called *pointer-supporting languages* and include Ada, C, Pascal, and PL/I. Languages that cannot access variables whose addresses are stored in the DATA_POINTER field of a foreign-data wrapper descriptor are called *non-pointer-supporting languages*. Such languages include COBOL, Fortran, and M.

The `GetDescriptor()` routine enables information to be retrieved from any foreign-data wrapper descriptor area. The `SetDescriptor()` routine enables information to be set in any foreign-data wrapper descriptor area.

The following foreign-data wrapper descriptor areas are either implicitly or explicitly allocated and deallocated:

- Table Reference Descriptor (TRD): This descriptor is allocated automatically by the SQL-server to describe a foreign table referenced in a foreign server request, and is associated with a `TableReferenceHandle` created by the SQL-server. The foreign-data wrapper can obtain the handle of a TRD by invoking the `GetTRDHandle()` routine. It can then retrieve the information in the associated TRD descriptor by invoking the `GetDescriptor()` routine.
- Wrapper Row Descriptor (WRD): This descriptor is allocated by the SQL-server if a foreign-data wrapper requests its allocation. It is used to describe the result of a foreign server request to be executed by that foreign-data wrapper in pass-through mode, and is associated with an `ExecutionHandle`. The foreign-data wrapper uses the `SetDescriptor()` routine to set information in the WRD. The SQL-server can obtain

the handle to a WRD by invoking the `GetWRDHandle()` routine. It can then retrieve the information in that WRD by invoking the `GetDescriptor()` routine.

- Server Row Descriptor (SRD): This descriptor is allocated by the SQL-server if a foreign-data wrapper requests its allocation. It is used by the SQL-server to specify the type and location of data to be provided by the foreign-data wrapper. SRD is also associated with an `ExecutionHandle`. The SQL-server can obtain the handle to a SRD by invoking the `GetSRDHandle()` routine. It can then set the information in that SRD by invoking the `SetDescriptor()` routine.
- Wrapper Parameter Descriptor (WPD): This descriptor is allocated by the SQL-server if a foreign-data wrapper requests its allocation. It is used to describe the input values required for the execution of a foreign server request by that foreign-data wrapper, and is associated with an `ExecutionHandle`. The foreign-data wrapper uses the `SetDescriptor()` routine to set information in the WPD. The SQL-server can obtain the handle to a WPD by invoking the `GetWPDHandle()` routine. It can then retrieve the information in that WPD by invoking the `GetDescriptor()` routine.
- Server Parameter Descriptor (SPD): This descriptor is allocated by the SQL-server if a foreign-data wrapper requests its allocation. It is used by the SQL-server to specify the type and location of input values to be provided by the SQL-server. The SPD is also associated with an `ExecutionHandle`. The SQL-server can obtain the handle to an SPD by invoking the `GetSPDHandle()` routine. It can then set the information in that SPD by invoking the `SetDescriptor()` routine.
- Value expression descriptor: This descriptor is implicitly allocated by the SQL-server for each value expression contained in a foreign server request. It is used to describe the most specific type and value of each value expression in the foreign server request. The foreign-data wrapper can obtain a handle to this descriptor by invoking the `GetValueExpDesc()` routine. It can retrieve information in that descriptor by invoking the `GetDescriptor()` routine.

Table 4 — Fields in foreign-data wrapper descriptor areas

Field	Data Type
COUNT	SMALLINT
DYNAMIC_FUNCTION	CHARACTER VARYING(L ¹)
DYNAMIC_FUNCTION_CODE	INTEGER
KEY_TYPE	SMALLINT
TOP_LEVEL_COUNT	SMALLINT
Implementation-defined foreign-data wrapper descriptor header field	Implementation-defined
CARDINALITY	INTEGER
CHARACTER_SET_CATALOG	CHARACTER VARYING(L ¹)
CHARACTER_SET_NAME	CHARACTER VARYING(L ¹)

CD ISO/IEC 9075-9:2007 (E)
4.17 Foreign-data wrapper interface

Field	Data Type
CHARACTER_SET_SCHEMA	CHARACTER VARYING(<i>L</i> ¹)
COLLATION_CATALOG	CHARACTER VARYING(<i>L</i> ¹)
COLLATION_NAME	CHARACTER VARYING(<i>L</i> ¹)
COLLATION_SCHEMA	CHARACTER VARYING(<i>L</i> ¹)
CURRENT_TRANSFORM_GROUP	CHARACTER VARYING(<i>L</i> ¹)
DATA	ANY
DATA_POINTER	host variable address
DATETIME_INTERVAL_CODE	SMALLINT
DATETIME_INTERVAL_PRECISION	SMALLINT
DEGREE	INTEGER
INDICATOR	INTEGER
KEY_MEMBER	SMALLINT
LENGTH	INTEGER
LEVEL	INTEGER
NAME	CHARACTER VARYING(<i>L</i> ¹)
NULLABLE	SMALLINT
OCTET_LENGTH	INTEGER
PARAMETER_MODE	SMALLINT
PARAMETER_ORDINAL_POSITION	SMALLINT
PARAMETER_SPECIFIC_CATALOG	CHARACTER VARYING(<i>L</i> ¹)
PARAMETER_SPECIFIC_NAME	CHARACTER VARYING(<i>L</i> ¹)
PARAMETER_SPECIFIC_SCHEMA	CHARACTER VARYING(<i>L</i> ¹)
PRECISION	SMALLINT
RETURNED_CARDINALITY	INTEGER

Field	Data Type
RETURNED_OCTET_LENGTH	INTEGER
SCALE	SMALLINT
SCOPE_CATALOG	CHARACTER VARYING(L^1)
SCOPE_NAME	CHARACTER VARYING(L^1)
SCOPE_SCHEMA	CHARACTER VARYING(L^1)
SPECIFIC_TYPE_CATALOG	CHARACTER VARYING(L^1)
SPECIFIC_TYPE_NAME	CHARACTER VARYING(L^1)
SPECIFIC_TYPE_SCHEMA	CHARACTER VARYING(L^1)
TYPE	SMALLINT
UNNAMED	SMALLINT
USER_DEFINED_TYPE_CATALOG	CHARACTER VARYING(L^1)
USER_DEFINED_TYPE_NAME	CHARACTER VARYING(L^1)
USER_DEFINED_TYPE_SCHEMA	CHARACTER VARYING(L^1)
Implementation-defined foreign-data wrapper descriptor item field	Implementation-defined
¹ Where L is an implementation-defined integer not less than 128, and $L1$ is the implementation-defined maximum length for the <general value specification> CURRENT_TRANSFORM_GROUP_FOR_TYPE.	

4.18 Introduction to SQL/CLI

This Subclause modifies Subclause 4.1, “Introduction to SQL/CLI”, in ISO/IEC 9075-3.

Insert this paragraph The BuildDataLink () routine can be used to build a datalink value. The GetDataLinkAttr () routine can be used to extract the attributes of a datalink value.

(Blank page)

5 Lexical elements

This Clause modifies Clause 5, “Lexical elements”, in ISO/IEC 9075-2.

5.1 <token> and <separator>

This Subclause modifies Subclause 5.2, “<token> and <separator>”, in ISO/IEC 9075-2.

Function

Specify lexical units (tokens and separators) that participate in SQL language.

Format

```
<non-reserved word> ::=  
!! All alternatives from ISO/IEC 9075-2  
| BLOCKED  
| CONTROL  
| DB  
| FILE | FS  
| INTEGRITY  
| LIBRARY | LIMIT | LINK  
| MAPPING  
| OFF  
| PASSTHROUGH | PERMISSION  
| RECOVERY | REQUIRING | RESTORE  
| SELECTIVE | SERVER  
| TOKEN  
| UNLINK  
| VERSION  
| WRAPPER  
| YES  
  
<reserved word> ::=  
!! All alternatives from ISO/IEC 9075-2  
| DATALINK | DLNEWCOPY | DLPREVIOUSCOPY | DLURLCOMPLETE | DLURLCOMPLETEWRITE  
| DLURLCOMPLETEONLY | DLURLPATH | DLURLPATHWRITE | DLURLPATHONLY  
| DLURLSCHEME | DLURLSERVER | DLVALUE  
| IMPORT
```

Syntax Rules

No additional Syntax Rules.

Access Rules

No additional Access Rules.

General Rules

No additional General Rules.

Conformance Rules

No additional Conformance Rules.

5.2 Names and identifiers

This Subclause modifies Subclause 5.4, “Names and identifiers”, in ISO/IEC 9075-2.

Function

Specify names.

Format

```
<foreign server name> ::=  
[ <catalog name> <period> ] <unqualified foreign server name>  
  
<foreign-data wrapper name> ::=  
[ <catalog name> <period> ] <unqualified foreign-data wrapper name>  
  
<unqualified foreign server name> ::= <qualified identifier>  
  
<unqualified foreign-data wrapper name> ::= <qualified identifier>  
  
<option name> ::= <identifier body>  
  
<routine mapping name> ::= <identifier>
```

Syntax Rules

- 1) Insert this SR If a <foreign server name> does not contain a <catalog name>, then
Case:
 - a) If the <foreign server name> is contained in a <preparable statement> that is prepared in the current SQL-session by an <execute immediate statement> or a <prepare statement> or in a <direct SQL statement> that is invoked directly, then the default catalog name for the SQL-session is implicit.
 - b) Otherwise, the <catalog name> that is specified or implicit for the SQL-client module is implicit.
- 2) Insert this SR If a <foreign-data wrapper name> does not contain a <catalog name>, then
Case:
 - a) If the <foreign-data wrapper name> is contained in a <preparable statement> that is prepared in the current SQL-session by an <execute immediate statement> or a <prepare statement> or in a <direct SQL statement> that is invoked directly, then the default catalog name for the SQL-session is implicit.
 - b) Otherwise, the <catalog name> that is specified or implicit for the SQL-client module is implicit.
- 3) Insert this SR In an <option name>, the number of <identifier part>s shall be less than 128.
- 4) Insert this SR The case-normal form of the <identifier body> of an <option name> is used for purposes such as and including determination of option name equivalence, representation in the Definition and Information Schemas, and representation in the diagnostics areas.
- 5) Insert this SR Two <option name>s are equivalent if the case-normal forms of their <identifier body>s, considered as the repetition of a <character string literal> that specifies a <character set specification> of

5.2 Names and identifiers

SQL_IDENTIFIER and a collation *IDC* that is sensitive to case, compare equal according to the comparison rules in Subclause 8.2, “<comparison predicate>”, in ISO/IEC 9075-2.

Access Rules

No additional Access Rules.

General Rules

- 1) Insert this GR A <foreign server name> identifies a foreign server.
- 2) Insert this GR A <foreign-data wrapper name> identifies a foreign-data wrapper.
- 3) Insert this GR A <routine mapping name> identifies a routine mapping.

Conformance Rules

No additional Conformance Rules.

6 Scalar expressions

This Clause modifies Clause 6, “Scalar expressions”, in ISO/IEC 9075-2.

6.1 <data type>

This Subclause modifies Subclause 6.1, “<data type>”, in ISO/IEC 9075-2.

Function

Specify a data type.

Format

```
<predefined type> ::=  
!! All alternatives from ISO/IEC 9075-2  
| <datalink type>  
  
<datalink type> ::= DATALINK [ <datalink control definition> ]  
  
<datalink control definition> ::=  
NO LINK CONTROL  
| FILE LINK CONTROL <datalink file control option>  
  
<datalink file control option> ::=  
<integrity control option> <read permission option> <write permission option>  
<recovery option> [ <unlink option> ]  
  
<integrity control option> ::=  
INTEGRITY ALL  
| INTEGRITY SELECTIVE  
  
<read permission option> ::=  
READ PERMISSION FS  
| READ PERMISSION DB  
  
<write permission option> ::=  
WRITE PERMISSION FS  
| WRITE PERMISSION ADMIN <access token indication>  
| WRITE PERMISSION BLOCKED  
  
<access token indication> ::=  
REQUIRING TOKEN FOR UPDATE  
| NOT REQUIRING TOKEN FOR UPDATE  
  
<recovery option> ::=  
RECOVERY NO
```

6.1 <data type>

```
| RECOVERY YES  
  
<unlink option> ::=  
ON UNLINK RESTORE  
| ON UNLINK DELETE
```

Syntax Rules

- 1) Insert this SR DATALINK specifies the datalink type.
- 2) Insert this SR If <data type> specifies DATALINK and <datalink control definition> is not specified, then NO LINK CONTROL is implicit.
- 3) Insert this SR If FILE LINK CONTROL is specified, then:
 - a) If INTEGRITY SELECTIVE is specified, then READ PERMISSION FS, WRITE PERMISSION FS, and RECOVERY NO shall be specified.
 - b) If READ PERMISSION DB is specified, then either WRITE PERMISSION BLOCKED or WRITE PERMISSION ADMIN shall be specified.
 - c) If either WRITE PERMISSION BLOCKED or WRITE PERMISSION ADMIN is specified, then INTEGRITY ALL and <unlink option> shall be specified.
 - d) If WRITE PERMISSION FS is specified, then READ PERMISSION FS and RECOVERY NO shall be specified and <unlink option> shall not be specified.
 - e) If RECOVERY YES is specified, then either WRITE PERMISSION BLOCKED or WRITE PERMISSION ADMIN shall be specified.
 - f) If UNLINK DELETE is specified, then READ PERMISSION DB shall be specified.

NOTE 26 — Valid combinations of <datalink file control option> resulting from this Syntax Rule are shown in Table 1, “Valid datalink file control options”.
- 4) Insert this SR If <datalink control definition> is specified, then <data type> shall not be contained in an <SQL variable declaration>.

Access Rules

No additional Access Rules.

General Rules

- 1) Insert this GR If <data type> is a <datalink type>, then a datalink type descriptor *DTD* is created. The link control options of *DTD* are:
 - a) The link control, according to whether NO LINK CONTROL or FILE LINK CONTROL is specified.
 - b) If FILE LINK CONTROL is specified, then:
 - i) The integrity control option, according to whether INTEGRITY ALL or INTEGRITY SELECTIVE is specified.

- ii) The read permission option, according to whether READ PERMISSION FS or READ PERMISSION DB is specified.
 - iii) The write permission option, according to whether WRITE PERMISSION FS, WRITE PERMISSION ADMIN, or WRITE PERMISSION BLOCKED is specified. If WRITE PERMISSION ADMIN is specified, then additionally the access token indication, according to whether REQUIRING TOKEN FOR UPDATE or NOT REQUIRING TOKEN FOR UPDATE is specified.
 - iv) The recovery option, according to whether RECOVERY NO or RECOVERY YES is specified.
 - v) The unlink option, according to whether ON UNLINK RESTORE or ON UNLINK DELETE is specified.
- c) If NO LINK CONTROL is specified, then:
- i) The integrity control option is NONE.
 - ii) The read permission option is FS.
 - iii) The write permission option is FS.
 - iv) The recovery option is NO.
 - v) The unlink option is NONE.

Conformance Rules

- 1) Without Feature M001, “Datalinks”, conforming SQL language shall not contain a <datalink type>.

6.2 <cast specification>

This Subclause modifies Subclause 6.12, “<cast specification>”, in ISO/IEC 9075-2.

Function

Specify a data conversion.

Format

No additional Format items.

Syntax Rules

- 1) Insert before SR 2) *TD* shall not contain a <datalink control definition>.
- 2) Replace SR 6) If the <cast operand> is a <value expression>, then the valid combinations of *TD* and *SD* in a <cast specification> are given by the following table. “Y” indicates that the combination is syntactically valid without restriction; “M” indicates that the combination is valid subject to other Syntax Rules in this Subclause being satisfied; and “N” indicates that the combination is not valid:

<data type> <i>SD</i> of <value expression>	EN	AN	VC	FC	D	T	TS	YM	DT	BO	UDT	CL	BL	RT	CT	RW	DL
EN	Y	Y	Y	Y	N	N	N	M	M	N	M	Y	N	M	N	N	N
AN	Y	Y	Y	Y	N	N	N	N	N	N	M	Y	N	M	N	N	N
C	Y	Y	Y	Y	Y	Y	Y	Y	Y	Y	M	Y	N	M	N	N	N
D	N	N	Y	Y	Y	N	Y	N	N	N	M	Y	N	M	N	N	N
T	N	N	Y	Y	N	Y	Y	N	N	N	M	Y	N	M	N	N	N
TS	N	N	Y	Y	Y	Y	Y	N	N	N	M	Y	N	M	N	N	N
YM	M	N	Y	Y	N	N	N	Y	N	N	M	Y	N	M	N	N	N
DT	M	N	Y	Y	N	N	N	N	Y	N	M	Y	N	M	N	N	N
BO	N	N	Y	Y	N	N	N	N	N	Y	M	Y	N	M	N	N	N
UDT	M	M	M	M	M	M	M	M	M	M	M	M	M	M	N	N	N
BL	N	N	N	N	N	N	N	N	N	N	M	N	Y	M	N	N	N
RT	M	M	M	M	M	M	M	M	M	M	M	M	M	M	N	N	N
CT	N	N	N	N	N	N	N	N	N	N	N	N	N	N	M	N	N
RW	N	N	N	N	N	N	N	N	N	N	N	N	N	N	N	M	N
DL	N	N	N	N	N	N	N	N	N	N	N	N	N	N	N	N	Y

Where:

- EN = Exact Numeric
- AN = Approximate Numeric
- C = Character (Fixed- or Variable-length, or character large object)
- FC = Fixed-length Character
- VC = Variable-length Character
- CL = Character Large Object
- D = Date
- T = Time
- TS = Timestamp

YM = Year-Month Interval
DT = Day-Time Interval
BO = Boolean
UDT = User-Defined Type
BL = Binary Large Object
RT = Reference type
CT = Collection type
RW = Row type
DL = Datalink

Access Rules

No additional Access Rules.

General Rules

- 1) Insert after GR 20 If *TD* and *SD* are datalink types, then *TV* is *SV*.

Conformance Rules

No additional Conformance Rules.

6.3 <value expression>

This Subclause modifies Subclause 6.25, “<value expression>”, in ISO/IEC 9075-2.

Function

Specify a value.

Format

```
<common value expression> ::=  
!! All alternatives from ISO/IEC 9075-2  
| <datalink value expression>
```

Syntax Rules

- 1) Replace SR 2) The declared type of a <common value expression> is the declared type of the <numeric value expression>, <string value expression>, <datetime value expression>, <interval value expression>, <user-defined type value expression>, <collection value expression>, <reference value expression>, or <datalink value expression>, respectively.

Access Rules

No additional Access Rules.

General Rules

No additional General Rules.

Conformance Rules

No additional Conformance Rules.

6.4 <string value function>

This Subclause modifies Subclause 6.29, “<string value function>”, in ISO/IEC 9075-2.

Function

Specify a function yielding a value of type character string or binary string.

Format

```
<string value function> ::=  
!! All alternatives from ISO/IEC 9075-2  
| <url complete expression>  
| <url complete for write expression>  
| <url complete only expression>  
| <url path expression>  
| <url path for write expression>  
| <url path only expression>  
| <url scheme expression>  
| <url server expression>  
  
<url complete expression> ::=  
DLURLCOMPLETE <left paren> <datalink value expression> <right paren>  
  
<url complete for write expression> ::=  
DLURLCOMPLETEWRITE <left paren> <datalink value expression> <right paren>  
  
<url complete only expression> ::=  
DLURLCOMPLETEONLY <left paren> <datalink value expression> <right paren>  
  
<url path expression> ::=  
DLURLPATH <left paren> <datalink value expression> <right paren>  
  
<url path for write expression> ::=  
DLURLPATHWRITE <left paren> <datalink value expression> <right paren>  
  
<url path only expression> ::=  
DLURLPATHONLY <left paren> <datalink value expression> <right paren>  
  
<url scheme expression> ::=  
DLURLSCHEME <left paren> <datalink value expression> <right paren>  
  
<url server expression> ::=  
DLURLSERVER <left paren> <datalink value expression> <right paren>
```

Syntax Rules

- 1) **Replace SR 1)** The declared type of <string value function> is the declared type of the immediately contained <character value function>, <blob value function>, <url complete expression>, <url complete for write expression>, <url complete only expression>, <url path expression>, <url path for write expression>, <url path only expression>, <url scheme expression>, or <url server expression>.
- 2) **Insert this SR** Let *DLCS* be the <character set name> of the datalink character set.

6.4 <string value function>

NOTE 27 — “datalink character set” is defined in Subclause 4.8, “Datalinks”.

- 3) **Insert this SR** Let *DVE* be the <datalink value expression>.
- 4) **Insert this SR** The declared type of <url complete expression> is variable-length character string with character set *DLCS* and an implementation-defined maximum length.
- 5) **Insert this SR** The declared type of <url complete for write expression> is variable-length character string with character set *DLCS* and an implementation-defined maximum length.
- 6) **Insert this SR** The declared type of <url complete only expression> is variable-length character string with character set *DLCS* and an implementation-defined maximum length.
- 7) **Insert this SR** The declared type of <url path expression> is variable-length character string with character set *DLCS* and an implementation-defined maximum length.
- 8) **Insert this SR** The declared type of <url path for write expression> is variable-length character string with character set *DLCS* and an implementation-defined maximum length.
- 9) **Insert this SR** The declared type of <url path only expression> is variable-length character string with character set *DLCS* and an implementation-defined maximum length.
- 10) **Insert this SR** The declared type of <url scheme expression> is variable-length character string with character set *DLCS* and an implementation-defined maximum length.
- 11) **Insert this SR** The declared type of <url server expression> is variable-length character string with character set *DLCS* and an implementation-defined maximum length.

Access Rules

No additional Access Rules.

General Rules

- 1) **Insert this GR** Let *DVE* be the <datalink value expression> simply contained in <string value function>. Let *DV* be the result of *DVE*. If *DV* is the null value, then the result of the <string value function> is the null value.
- 2) **Insert this GR** If <url complete expression> is specified, then
Case:
 - a) If *DV* is SQL-mediated, then the result is the File Reference of *DV* combined with a read token in an implementation-dependent manner.
 - b) Otherwise, the result is the File Reference of *DV*.
- 3) **Insert this GR** If <url complete for write expression> is specified, then
Case:
 - a) If *DV* is SQL-mediated and the SQL-Mediated Write Access Indication of *DV* is *True*, then the result is the File Reference of *DV* combined with a write token in an implementation-dependent manner.
 - b) Otherwise, the result is the File Reference of *DV*.

- 4) Insert this GR If <url complete only expression> is specified, then the result is the File Reference of *DV*.
- 5) Insert this GR If <url path expression> is specified, then the result is

Case:

- a) If the File Reference of *DV* contains an <http url> that contains an <hpath> *HP*, then

Case:

- i) If *DV* is SQL-mediated, then *HP* combined with a read token in an implementation-dependent manner.
- ii) Otherwise, *HP*.

- b) If the File Reference of *DV* contains a <file url>, that contains an <fpath> *FP*, then

Case:

- i) If *DV* is SQL-mediated, then *FP* combined with a read token in an implementation-dependent manner.
- ii) Otherwise, *FP*.

- c) If the File Reference of *DV* conforms to an implementation-defined format, then an implementation-defined value.
- d) Otherwise, a zero-length character string.

- 6) Insert this GR If <url path for write expression> is specified, then the result is

Case:

- a) If the File Reference of *DV* contains an <http url> that contains an <hpath> *HP*, then

Case:

- i) If *DV* is SQL-mediated and the SQL-Mediated Write Access Indication of *DV* is True, then *HP* combined with a write token in an implementation-dependent manner.
- ii) Otherwise, *HP*.

- b) If the File Reference of *DV* contains a <file url> that contains an <fpath> *FP*, then

Case:

- i) If *DV* is SQL-mediated and the SQL-Mediated Write Access Indication of *DV* is True, then *FP* combined with a write token in an implementation-dependent manner.
- ii) Otherwise, *FP*.

- c) If the File Reference of *DV* conforms to an implementation-defined format, then an implementation-defined value.
- d) Otherwise, a zero-length character string.

- 7) Insert this GR If <url path only expression> is specified, then the result is

Case:

6.4 <string value function>

- a) If the File Reference of *DV* contains an <http url> that contains an <hpath> *HP*, then *HP*, excluding any access token.
 - b) If the File Reference of *DV* contains a <file url>, then the <fpath> contained in that <file url>.
 - c) If the File Reference of *DV* conforms to an implementation-defined format, then an implementation-defined value.
 - d) Otherwise, a zero-length character string.
- 8) Insert this GR If <url scheme expression> is specified, then the result is
- Case:
- a) If the File Reference of *DV* contains an <http url>, then the <http> contained in that <http url>.
 - b) If the File Reference of *DV* contains a <file url>, then the <file> contained in that <file url>.
 - c) If the File Reference of *DV* conforms to an implementation-defined format, then an implementation-defined value.
 - d) Otherwise, a zero-length character string.
- 9) Insert this GR If <url server expression> is specified, then the result is
- Case:
- a) If the File Reference of *DV* contains an <http url>, then the <host> contained in that <http url>.
 - b) If the File Reference of *DV* contains a <file url>, then the <host> contained in that <file url>.
 - c) If the File Reference of *DV* conforms to an implementation-defined format, then an implementation-defined value.
 - d) Otherwise, a zero-length character string.

Conformance Rules

No additional Conformance Rules.

6.5 <datalink value expression>

Function

Specify a datalink value.

Format

```
<datalink value expression> ::=  
<datalink value function>  
| <value expression primary>
```

Syntax Rules

- 1) The declared type of <value expression primary> shall be DATALINK.

Access Rules

None.

General Rules

- 1) Case:
 - a) If <datalink value function> *DVF* is specified, then the result of the <datalink value expression> is the result of *DVF*.
 - b) If <value expression primary> *VEP* is specified, then the result of the <datalink value expression> is the result of *VEP*.

Conformance Rules

- 1) Without Feature M001, “Datalinks”, conforming SQL language shall not contain a <datalink value expression>.

6.6 <datalink value function>

Function

Specify a function yielding a datalink value.

Format

<datalink value function> ::= <datalink value constructor>

<datalink value constructor> ::=

DLVALUE <left paren> <data location> <right paren>

| DLNEWCOPY <left paren> <data location> <comma> <token indication> <right paren>

| DLPREVIOUSCOPY <left paren> <data location> <comma> <token indication> <right paren>

<data location> ::= <character value expression>

<token indication> ::= <unsigned integer>

Syntax Rules

- 1) The declared type of a <datalink value constructor> *DVC* is DATALINK.
- 2) The declared type of a <datalink value function> is the declared type of its <datalink value constructor>.
- 3) The character set name of the declared type of <data location> shall be equivalent to the character set name of the datalink character set.

NOTE 28 — “datalink character set” is defined in [Subclause 4.8](#), “Datalinks”.

Access Rules

None.

General Rules

- 1) Let *DLOC* be the result of evaluating <data location>.
 - a) If DLVALUE is specified and *DLOC* is the null value, then the result of *DVC* is the null value.
 - b) If either DLNEWCOPY or DLPREVIOUSCOPY is specified, then:
 - i) Let *TIV* the result of evaluating <token indication>.
 - ii) If *TIV* is neither equal to 0 (zero) nor 1 (one), then an exception condition is raised: *data exception — invalid parameter value*.
 - iii) If *DLOC* is the null value, then an exception condition is raised: *data exception — null argument passed to datalink constructor*.

- iv) If *TIV* is equal to 1 (one) and if the write token included in *DLOC* does not conform to implementation-defined requirements, then an exception condition is raised: *datalink exception — invalid write token*.
- c) Case:
 - i) If *DLVALUE* is specified, then let *DLOCWOT* be *DLOC*.
 - ii) Otherwise:
 - 1) If *TIV* is equal to 0 (zero), then let *DLOCWOT* be *DLOC*.
 - 2) If *TIV* is equal to 1 (one), then let *DLOCWOT* be *DLOC* without the write token included in *DLOC* and let *WT* be the write token included in *DLOC*.
- d) If *DLOCWOT* conforms neither to the Format of Subclause 8.1, “URL format”, nor to an implementation-defined format, then an exception condition is raised: *data exception — invalid data specified for datalink*.
- e) If the number of octets occupied by the implementation-defined representation of the results of *DVC* exceeds the maximum datalink length, then an exception condition is raised: *data exception — datalink value exceeds maximum length*.

NOTE 29 — The term “maximum datalink length” is defined in Subclause 4.8, “Datalinks”.
- f) Otherwise, the result of *DVC* is the datalink value *DL* such that:
 - i) The File Reference of *DL* is *DLOCWOT*.

Case:

 - 1) If *DLOCWOT* conforms to the Format of Subclause 8.1, “URL format”, then

Case:

 - A) If *DLOCWOT* contains an <http url>, then the <http>, <host>, and <hpath> contained in the <http url> are the *scheme* of *DL*, the *host* of *DL*, and the *path* of *DL*, respectively.
 - B) If *DLOCWOT* contains a <file url>, then the <file>, <host>, and <fpath> contained in the <file url> are the *scheme* of *DL*, the *host* of *DL*, and the *path* of *DL*, respectively.
 - 2) Otherwise, the *scheme* of *DL*, the *host* of *DL*, and the *path* of *DL* are implementation-defined.
 - ii) The SQL-Mediated Read Access Indication of *DL* is *False*.
 - iii) The SQL-Mediated Write Access Indication of *DL* is *False*.
 - iv) Case:
 - 1) If either *DLNEWCOPY* or *DLPREVIOUSCOPY* is specified and *TIV* is equal to 1 (one), then the Write Token of *DL* is *WT*.
 - 2) Otherwise, the Write Token of *DL* is the null value.
 - v) Case:
 - 1) If *DLNEWCOPY* is specified, then the Construction Indication of *DL* is *NEWCOPY*.
 - 2) If *DLPREVIOUSCOPY* is specified, then the Construction Indication of *DL* is *PREVIOUSCOPY*.

6.6 <datalink value function>

- 3) Otherwise, the Construction Indication of *DL* is the null value.
- 2) The result of a <datalink value function> *DVF* is the result of the <datalink value constructor> contained in *DVF*.

Conformance Rules

- 1) Without Feature M001, “Datalinks”, conforming SQL language shall not contain a <datalink value function>.

7 Query expressions

This Clause modifies Clause 7, “Query expressions”, in ISO/IEC 9075-2.

7.1 <table reference>

This Subclause modifies Subclause 7.6, “<table reference>”, in ISO/IEC 9075-2.

Function

Reference a table.

Format

No additional Format items.

Syntax Rules

No additional Syntax Rules.

Access Rules

No additional Access Rules.

General Rules

- 1) Replace GR 1)c) Otherwise, let T be the table specified by the <table name> simply contained in TP .

Case:

- a) If T is a view or a base table, then

Case:

- i) If ONLY is specified, then the result of TP is a table that consists of every row in T , except those rows that have a subrow in a proper subtable of T .
- ii) Otherwise, the result of TP is a table that consists of every row of T .
- b) If T is a foreign table with <table name> FTN , then the result of TP is effectively determined as follows:
- i) Let FSN be the name of the foreign server included in the table descriptor of the foreign table identified by FTN . Let WN be the name of the foreign-data wrapper included in the foreign

server descriptor of the foreign server identified by *FSN*. Let *WR* be the foreign-data wrapper identified by *WN*. Let *WRLN* be the name of the library identified in the foreign-data wrapper descriptor of *WR*.

- ii) Case:
 - 1) If the current SQL-session context includes a {foreign-data wrapper name : WrapperEnvHandle} pair whose foreign-data wrapper name is equivalent to *WN*, then let *WEH* be the WrapperEnvHandle associated with *WN*.
 - 2) Otherwise:
 - A) Let *WH* be the WrapperHandle allocated for the foreign-data wrapper identified by *WN*. The resource identified by *WH* is referred to as an *allocated foreign-data wrapper description*.
 - B) Let *WEH* be the WrapperEnvHandle returned by invocation of `AllocWrapperEnv()` in the library identified by *WRLN*, with *WH* as the argument).
 - C) The {*WN* : *WEH*} pair is included in the current SQL-session context.
 - D) *WH* is deallocated and all its resources are freed.
- iii) Case:
 - 1) If the current SQL-session context includes a {foreign server name : FSConnectionHandle} pair whose foreign server name is equivalent to *FSN*, then let *FSCH* be the FSConnectionHandle associated with *FSN*.
 - 2) Otherwise:
 - A) Let *SH* be the ServerHandle allocated for the foreign server identified by *FSN*. The resource identified by *SH* is referred to as an *allocated foreign server description*.
 - B) If there is a user mapping identified by the current authorization identifier, then let *UH* be the UserHandle allocated for that user mapping; otherwise, let *UH* be the UserHandle allocated for the user mapping identified by PUBLIC. The resource identified by *UH* is referred to as an *allocated user mapping description*.
 - C) Let *FSCH* be the FSConnectionHandle returned by invocation of the `ConnectServer()` in the library identified by *WRLN* with *WEH*, *SH*, and *UH* as the arguments.
 - D) The {*FSN* : *FSCH*} pair is included in the current SQL-session context.
 - E) *SH* is deallocated and all its resources are freed.
 - F) *UH* is deallocated and all its resources are freed.
- iv) Let *QCH* be the QueryContextHandle returned by invocation of the `AllocQueryContext()` in the library identified by *WRLN* with *FSCH* as input argument.
- v) Let *TEMP* be either a <query specification> of the form “SELECT * FROM *FTN*” or a <query specification> *IDQS* of the form “SELECT *DistinctOrAll exp₁, exp₂, ..., exp_n* FROM *FTN₁, FTN₂, ..., FTN_m* WHERE *BVE₁* AND *BVE₂* AND ... AND *BVE_p*”, where all of the following are true:
 - 1) *DistinctOrAll* is either “DISTINCT” or “ALL”.

- 2) n , m , and p are implementation-dependent numeric values.
 - 3) For all i , $1 \text{ (one)} \leq i \leq n$, exp_i is an implementation-dependent <value expression> that does not generally contain a <subquery>.
 - 4) For all i , $1 \text{ (one)} \leq i \leq m$, FTN_i is a <foreign table>, and at least one of FTN_i shall be equivalent to FTN .
 - 5) For all i , $1 \text{ (one)} \leq i \leq m$, the table descriptor of FTN_i shall include a foreign server descriptor that is equal to FSN .
 - 6) For all i , $1 \text{ (one)} \leq i \leq p$, BVE_i is a <boolean value expression> that does not generally contain a <subquery>.
- vi) Let RQH be the RequestHandle allocated for $TEMP$.
 - vii) Let NTR be the number of <table reference>s in $TEMP$. Let TRH_i , $1 \text{ (one)} \leq i \leq NTR$, be the TableReferenceHandle allocated for each <table reference> simply contained in $TEMP$.
 - viii) Let N be the number of <value expression>s generally contained in the <select list> simply contained in $TEMP$. Let CN_i , $1 \text{ (one)} \leq i \leq N$, be the i -th such <value expression>. Let VEH_i , $1 \text{ (one)} \leq i \leq N$ be the i -th ValueExpressionHandle allocated for CN_i .
 - ix) Let M be the number of <value expression>s generally contained in the <where clause> simply contained in $TEMP$. Let CN_i , $N+1 \leq i \leq N+M$, be the i -th such <value expression>. Let VEH_i , $N+1 \leq i \leq N+M$, be the i -th ValueExpressionHandle allocated for CN_i .
 - x) For all i , $1 \text{ (one)} \leq i \leq N+M$, if CN_i identifies an <SQL-invoked routine> whose specific name is SRN and there exists a routine mapping descriptor that contains a specific routine name that is equivalent to SRN and a foreign server name that is equivalent to FSN , then let RH_i be the RoutineMappingHandle allocated for that routine mapping. The resource identified by RH_i is referred to as an *allocated routine mapping description*. RH_i is associated with VEH_i .
 - xi) For all i , $1 \text{ (one)} \leq i \leq N+M$, if CN_i is a <column reference> of a table reference TRH_j , then VEH_i is associated with TRH_j .
 - xii) For each CN_i , $1 \text{ (one)} \leq i \leq N+M$, a value expression descriptor is allocated that describes the most specific type and value of CN_i . The value of the TOP_LEVEL_COUNT header field is set to 1 (one). The value of each remaining header field and the value of each field in the contained item descriptor area and subordinate item descriptor field, if any, are implementation-dependent. Let $VEDH_i$ be the ValueExpressionDescriptorHandle associated with the value expression descriptor allocated for CN_i . $VEDH_i$ is associated with VEH_i .
 - xiii) A table reference descriptor TRD is automatically allocated. Each of the fields in TRD that have non-blank entries in Table 34, “Foreign-data wrapper descriptor field default values”, is set to the specified default value. All other fields in TRD are initially undefined.
 - xiv) The General Rules of Subclause 21.4, “Implicit DESCRIBE OUTPUT USING clause”, are applied with $TEMP$ and TRD as $SOURCE$ and $DESCRIPTOR$, respectively.

- xv) A wrapper parameter descriptor *WPD* is automatically allocated. Each of the fields in *WPD* that have non-blank entries in Table 34, “Foreign-data wrapper descriptor field default values”, is set to the specified default value. All other fields in *WPD* are initially undefined. Let *WPDH* be the handle associated with *WPD*.
- xvi) The General Rules of Subclause 21.3, “Implicit DESCRIBE INPUT USING clause”, are applied with *TEMP* and *WPD* as *SOURCE* and *DESCRIPTOR*, respectively.
- xvii) Let *TRDH* be the TableReferenceDescriptorHandle allocated for *TRD*.
- xviii) Let *RPH* and *EXH* be the ReplyHandle and ExecutionHandle, respectively, returned by the invocation of `AdvanceInitRequest()` in the library identified by *WRLN* with *FSCH* and *RQH*, *QCH* as input arguments.
- xix) *TRD* and *WPD* are associated with *EXH*.
- xx) Let *NRTR* be the NumberOfTableReferences that would be returned by an invocation of `GetNumReplyTableRefs()` with *RPH* as the ReplyHandle parameter.
- xxi) Let *TRN_i*, $1 \text{ (one)} \leq i \leq \text{NRTR}$, be the TableReferenceNumber that would be returned by an invocation of `GetReplyTableRef()` with *RPH* as the ReplyHandle parameter and *i* as the Index parameter.
- xxii) Let *NSLE* be the NumberOfSelectListElements that would be returned by an invocation of `GetNumReplySelectElems()` with *RPH* as the ReplyHandle parameter.
- xxiii) Let *SELN_i*, $1 \text{ (one)} \leq i \leq \text{NSLE}$, be the SelectListElementNumber that would be returned by an invocation of `GetReplySelectElem()` with *RPH* as the ReplyHandle parameter and *i* as the Index parameter.
- xxiv) Let *NBVE* be the NumberOfBoolVEs that would be returned by an invocation of `GetNumReplyBoolVE()` with *RPH* as the ReplyHandle parameter.
- xxv) Let *BVEN_i*, $1 \text{ (one)} \leq i \leq \text{NBVE}$, be the BoolVENumber that would be returned by an invocation of `GetReplyBoolVE()` with *RPH* as the ReplyHandle parameter and *i* as the Index parameter.
- xxvi) Let *RCA* be the ReplyCardinality that would be returned by an invocation of `GetReplyCardinality()` with *RPH* as the ReplyHandle parameter.
- xxvii) Let *REFC* be the ReplyExecFirstCost that would be returned by an invocation of `GetReplyFirstCost()` with *RPH* as the ReplyHandle parameter.
- xxviii) Let *RTEC* be the ReplyTotalExecCost that would be returned by an invocation of `GetReplyExecCost()` with *RPH* as the ReplyHandle parameter.
- xxix) Let *RREC* be the ReplyReExecutionCost that would be returned by an invocation of `GetReplyReExecCost()` with *RPH* as the ReplyHandle parameter.
- xxx) It is implementation-dependent whether the `NextReply()` routine with *RPH* as the ReplyHandle parameter is invoked. If the `NextReply()` routine is invoked, then let *RPHN* and *EXHN* be the ReplyHandle and ExecutionHandle, respectively, returned by that invocation; General Rules 1)b)xx) through 1)b)xxx) of this Subclause are applied with *RPHN* and *EXHN* as *RPH* and *EXH*, respectively.

- xxxix) The `FreeReplyHandle()` routine in the library identified by *WRLN* is invoked with *RPH* as the argument.
- xxxii) It is implementation-dependent whether General Rules 1)b)iv) through 1)b)xxxii) of this Subclause are applied once again.
- xxxiii) Let *NC* be the value of the COUNT descriptor field that would be returned by invocation of `GetDescriptor()` with *TRDH* as the DescriptorHandle parameter, 0 (zero) as the Record-Number parameter, and the code for COUNT from Table 30, “Codes used for foreign-data wrapper descriptor fields”, as the FieldIdentifier parameter.
- xxxiv) Let *DT_j* be the effective data type of the *j*-th column, for $1 \text{ (one)} \leq j \leq NC$, as represented by the values of the TYPE, LENGTH, OCTET_LENGTH, PRECISION, SCALE, DATETIME_INTERVAL_CODE, DATETIME_INTERVAL_PRECISION, CHARACTER_SET_CATALOG, CHARACTER_SET_SCHEMA, CHARACTER_SET_NAME, USER_DEFINED_TYPE_CATALOG, USER_DEFINED_TYPE_SCHEMA, USER_DEFINED_TYPE_NAME, SCOPE_CATALOG, SCOPE_SCHEMA, and SCOPE_NAME fields that would be returned by separate invocations of `GetDescriptor()` with *TRDH* as the DescriptorHandle parameter, *j* as the RecordNumber parameter, and the code for the fields TYPE, LENGTH, OCTET_LENGTH, PRECISION, SCALE, DATETIME_INTERVAL_CODE, DATETIME_INTERVAL_PRECISION, CHARACTER_SET_CATALOG, CHARACTER_SET_SCHEMA, CHARACTER_SET_NAME, USER_DEFINED_TYPE_CATALOG, USER_DEFINED_TYPE_SCHEMA, USER_DEFINED_TYPE_NAME, SCOPE_CATALOG, SCOPE_SCHEMA, and SCOPE_NAME from Table 30, “Codes used for foreign-data wrapper descriptor fields”, as the FieldIdentifier parameter.
- xxxv) Let *SRD* be the SRDHandle that would be returned by an invocation of `GetSRDHandle()` with *EXH* as the ExecutionHandle parameter.
- xxxvi) Let *TDT_j* be the effective data type of the *j*-th <target specification>, for $1 \text{ (one)} \leq j \leq NC$, as represented by the values of the TYPE, LENGTH, OCTET_LENGTH, PRECISION, SCALE, DATETIME_INTERVAL_CODE, DATETIME_INTERVAL_PRECISION, CHARACTER_SET_CATALOG, CHARACTER_SET_SCHEMA, CHARACTER_SET_NAME, USER_DEFINED_TYPE_CATALOG, USER_DEFINED_TYPE_SCHEMA, USER_DEFINED_TYPE_NAME, SCOPE_CATALOG, SCOPE_SCHEMA, and SCOPE_NAME fields that would be set by separate invocations of `SetDescriptor()` with *SRD* as the DescriptorHandle parameter, *j* as the RecordNumber parameter, and the code for the fields TYPE, LENGTH, OCTET_LENGTH, PRECISION, SCALE, DATETIME_INTERVAL_CODE, DATETIME_INTERVAL_PRECISION, CHARACTER_SET_CATALOG, CHARACTER_SET_SCHEMA, CHARACTER_SET_NAME, USER_DEFINED_TYPE_CATALOG, USER_DEFINED_TYPE_SCHEMA, USER_DEFINED_TYPE_NAME, SCOPE_CATALOG, SCOPE_SCHEMA, and SCOPE_NAME from Table 30, “Codes used for foreign-data wrapper descriptor fields”, as the FieldIdentifier parameter. TYPE either indicates ROW or is one of the code values in Table 15, “Codes used for application data types in SQL/CLI”.
- xxxvii) For every *DT_j* and *TDT_j*, $1 \text{ (one)} \leq j \leq NC$:
- 1) If *DT_j* is an array data type and *TDT_j* is not an array locator data type, then an exception condition is raised: *FDW-specific condition — invalid data type descriptors*.
 - 2) If *DT_j* is a multiset data type and *TDT_j* is not a multiset locator data type, then an exception condition is raised: *FDW-specific condition — invalid data type descriptors*.

3) If DT_j is a row data type, then

Case:

A) If TDT_j is not a row data type, then an exception condition is raised: *FDW-specific condition — invalid data type descriptors*.

B) If TDT_j is a row data type and DT_j and TDT_j do not conform to the Syntax Rules of Subclause 9.16, “Data type identity”, in ISO/IEC 9075-2, then an exception condition is raised: *FDW-specific condition — invalid data type descriptors*.

4) If DT_j and TDT_j are predefined data types, then let HL be the standard programming language in which the invoking SQL-server is written. Let *operative data type correspondence table* be the data type correspondence table for HL as specified in Subclause 19.5, “SQL/CLI data type correspondences”. Refer to the two columns of the operative data type correspondence table as the “SQL data type column” and the “host data type column”.

Case:

A) If the row that contains the SQL data type corresponding to DT_j in the SQL data type column of the operative data type correspondence table contains “None” in the host data type column, and TDT_j is not a character string type, then an exception condition is raised: *FDW-specific condition — invalid data type descriptors*.

B) Otherwise, if DT_j and TDT_j do not conform to the Syntax Rules of Subclause 9.16, “Data type identity”, in ISO/IEC 9075-2, then an exception condition is raised: *FDW-specific condition — invalid data type descriptors*.

5) If DT_j is a user-defined type, then an exception condition is raised: *FDW-specific condition — invalid data type descriptors*.

xxxviii) Let NP be the value of the COUNT descriptor field that would be returned by invocation of `GetDescriptor()` with $WPDH$ as the DescriptorHandle parameter, 0 (zero) as the Record-Number parameter, and the code for COUNT from Table 30, “Codes used for foreign-data wrapper descriptor fields”, as the FieldIdentifier parameter.

xxxix) Let PDT_j be the effective data type of the j -th column, for $1 \text{ (one)} \leq j \leq NP$, as represented by the values of the TYPE, LENGTH, OCTET_LENGTH, PRECISION, SCALE, DATE-TIME_INTERVAL_CODE, DATETIME_INTERVAL_PRECISION, CHARACTER_SET_CATALOG, CHARACTER_SET_SCHEMA, CHARACTER_SET_NAME, USER_DEFINED_TYPE_CATALOG, USER_DEFINED_TYPE_SCHEMA, USER_DEFINED_TYPE_NAME, SCOPE_CATALOG, SCOPE_SCHEMA, and SCOPE_NAME fields that would be returned by separate invocations of `GetDescriptor()` with $WPDH$ as the DescriptorHandle parameter, j as the RecordNumber parameter, and the code for the fields TYPE, LENGTH, OCTET_LENGTH, PRECISION, SCALE, DATETIME_INTERVAL_CODE, DATETIME_INTERVAL_PRECISION, CHARACTER_SET_CATALOG, CHARACTER_SET_SCHEMA, CHARACTER_SET_NAME, USER_DEFINED_TYPE_CATALOG, USER_DEFINED_TYPE_SCHEMA, USER_DEFINED_TYPE_NAME, SCOPE_CATALOG, SCOPE_SCHEMA, and SCOPE_NAME from Table 30, “Codes used for foreign-data wrapper descriptor fields”, as the FieldIdentifier parameter.

xl) Let SPD be the SPDHandle that would be returned by an invocation of `GetSPDHandle()` with EXH as the ExecutionHandle parameter.

- xli) Let SDT_j be the effective data type of the j -th <target specification>, for 1 (one) $\leq j \leq NP$, as represented by the values of the TYPE, LENGTH, OCTET_LENGTH, PRECISION, SCALE, DATETIME_INTERVAL_CODE, DATETIME_INTERVAL_PRECISION, CHARACTER_SET_CATALOG, CHARACTER_SET_SCHEMA, CHARACTER_SET_NAME, USER_DEFINED_TYPE_CATALOG, USER_DEFINED_TYPE_SCHEMA, USER_DEFINED_TYPE_NAME, SCOPE_CATALOG, SCOPE_SCHEMA, and SCOPE_NAME fields that would be set by separate invocations of `SetDescriptor()` with SPD as the DescriptorHandle parameter, j as the RecordNumber parameter, and the code for the fields TYPE, LENGTH, OCTET_LENGTH, PRECISION, SCALE, DATETIME_INTERVAL_CODE, DATETIME_INTERVAL_PRECISION, CHARACTER_SET_CATALOG, CHARACTER_SET_SCHEMA, CHARACTER_SET_NAME, USER_DEFINED_TYPE_CATALOG, USER_DEFINED_TYPE_SCHEMA, USER_DEFINED_TYPE_NAME, SCOPE_CATALOG, SCOPE_SCHEMA, and SCOPE_NAME from Table 30, “Codes used for foreign-data wrapper descriptor fields”, as the FieldIdentifier parameter. TYPE either indicates ROW or is one of the code values in Table 15, “Codes used for application data types in SQL/CLI”.
- xlii) For every PDT_j and SDT_j , 1 (one) $\leq j \leq NP$:
- 1) If PDT_j is an array data type and SDT_j is not an array locator data type, then an exception condition is raised: *FDW-specific condition — invalid data type descriptors*.
 - 2) If PDT_j is a multiset data type and SDT_j is not a multiset locator data type, then an exception condition is raised: *FDW-specific condition — invalid data type descriptors*.
 - 3) If PDT_j is a row data type, then

Case:

 - A) If SDT_j is not a row data type, then an exception condition is raised: *FDW-specific condition — invalid data type descriptors*.
 - B) If SDT_j is a row data type and PDT_j and SDT_j do not conform to the Syntax Rules of Subclause 9.16, “Data type identity”, in ISO/IEC 9075-2, then an exception condition is raised: *FDW-specific condition — invalid data type descriptors*.
 - 4) If PDT_j and SDT_j are predefined data types, then let HL be the standard programming language in which the invoking SQL-server is written. Let operative data type correspondence table be the data type correspondence table for HL as specified in Subclause 19.5, “SQL/CLI data type correspondences”. Refer to the two columns of the operative data type correspondence table as the “SQL data type column” and the “host data type column”.

Case:

 - A) If the row that contains the SQL data type corresponding to PDT_j in the SQL data type column of the operative data type correspondence table contains “None” in the host data type column, and SDT_j is not a character string type, then an exception condition is raised: *FDW-specific condition — invalid data type descriptors*.
 - B) Otherwise, if PDT_j and SDT_j do not conform to the Syntax Rules of Subclause 9.16, “Data type identity”, in ISO/IEC 9075-2, then an exception condition is raised: *FDW-specific condition — invalid data type descriptors*.

- 5) If DT_j is a user-defined type, then an exception condition is raised: *FDW-specific condition* — *invalid data type descriptors*.
- xliv) For all VEH_i , $1 \text{ (one)} \leq i \leq N+M$, let RH_i be the allocated routine mapping description associated with VEH_i , if any. RH_i is deallocated and all its resources are freed.
- xliv) VEH_i , $1 \text{ (one)} \leq i \leq N+M$, is deallocated and all its resources are freed.
- xliv) TRH is deallocated and all its resources are freed.
- xlvi) RQH is deallocated and all its resources are freed.
- xlvi) The `Open ()` routine in the library identified by $WRLN$ is invoked with EXH as the argument.
- xlvi) The result of TP is a table that consists of every row returned by the repeated invocation of `Iterate ()` in the library identified by $WRLN$ with EXH as the argument until the return code indicates **No data found**.
- xlvi) The `Close ()` routine in the library identified by $WRLN$ is invoked with EXH as the argument.
- l) The `FreeExecutionHandle ()` routine in the library identified by $WRLN$ is invoked with EXH as the argument.

Conformance Rules

No additional Conformance Rules.

8 URLs

8.1 URL format

Function

Specify the precise format of a URL within a datalink. The specification is a direct translation of the format of HTTP and FILE URLs specified in [RFC2396], except that “localhost” has been omitted from the format of FILE URL. [RFC2396] and [RFC2368] specify other URL schemes; URLs formatted according to those other schemes are not supported within datalinks.

Format

```
<url> ::=  
<http url>  
| <file url>  
  
<http url> ::= <http> <colon> <solidus> <solidus> <host port> [ <solidus> <hpath> ]  
  
<http> ::= { h | H } { t | T } { t | T } { p | P }  
  
<host port> ::= <host> [ <colon> <port> ]  
  
<host> ::=  
<host name>  
| <host number>  
  
<host name> ::= [ { <domain label> <period> }... ] <top label>  
  
<domain label> ::=  
<letter or digit>  
| <letter or digit> <label tail>  
  
<letter or digit> ::=  
<simple Latin letter>  
| <digit>  
  
<label tail> ::= [ { <letter or digit> | <minus sign> }... ] <letter or digit>  
  
<top label> ::=  
<simple Latin letter>  
| <simple Latin letter> <label tail>  
  
<host number> ::= <digits> <period> <digits> <period> <digits> <period> <digits>  
  
<digits> ::= <digit>...  
  
<port> ::= <digits>  
  
<hpath> ::= <hsegment> [ { <solidus> <hsegment> }... ]
```

CD ISO/IEC 9075-9:2007 (E)

8.1 URL format

```
<hsegment> ::= [ <hsegment character>... ]

<hsegment character> ::=
<uchar>
| <colon>
| <commercial at>
| <ampersand>
| <equals operator>

<uchar> ::=
<unreserved>
| <escape>

<unreserved> ::=
<simple Latin letter>
| <digit>
| <safe>
| <extra>

<safe> ::=
<dollar sign>
| <minus sign>
| <underscore>
| <period>
| <plus sign>

<extra> ::=
<exclamation point>
| <asterisk>
| <quote>
| <left paren>
| <right paren>
| <comma>

<escape> ::= <percent> <hexit> <hexit>

<file url> ::= <file> <colon> <solidus> <solidus> <host> <solidus> <fpath>

<file> ::= { f | F } { i | I } { l | L } { e | E }

<fpath> ::= <fsegment> [ { <solidus> <fsegment> }... ]

<fsegment> ::= [ <fsegment character>... ]

<fsegment character> ::=
<uchar>
| <question mark>
| <colon>
| <commercial at>
| <ampersand>
| <equals operator>

<commercial at> ::= @

<dollar sign> ::= $

<exclamation point> ::= !
```

Syntax Rules

- 1) In an SQL-environment, a <url> shall reference the same file, regardless of which component in the SQL-environment is interpreting the <url>.

Access Rules

None.

General Rules

None.

Conformance Rules

None.

(Blank page)

9 Additional common rules

This Clause modifies Clause 9, “Additional common rules”, in ISO/IEC 9075-2.

9.1 Retrieval assignment

This Subclause modifies Subclause 9.1, “Retrieval assignment”, in ISO/IEC 9075-2.

Function

Specify rules for assignments to targets that do not support null values or that support null values with indicator parameters (*e.g.*, assigning SQL-data to host parameters or host variables).

Syntax Rules

- 1) Insert this SR If the declared type of *T* is DATALINK, then the declared type of *V* shall be DATALINK.

Access Rules

No additional Access Rules.

General Rules

- 1) Insert after GR 6p) If the declared type of *T* is DATALINK, then the value of *T* is set to *V*.

Conformance Rules

No additional Conformance Rules.

9.2 Store assignment

This Subclause modifies Subclause 9.2, “Store assignment”, in ISO/IEC 9075-2.

Function

Specify rules for assignments where the target permits null without the use of indicator parameters or indicator variables, such as storing SQL-data or setting the value of SQL parameters.

Syntax Rules

- 1) Insert this SR If the declared type of T is DATALINK, then the declared type of V shall be DATALINK.

Access Rules

No additional Access Rules.

General Rules

- 1) Insert after GR 2)b)xvi If the declared type of T is DATALINK, then the value of T is set to V .

Conformance Rules

No additional Conformance Rules.

9.3 Data types of results of aggregations

This Subclause modifies Subclause 9.3, “Data types of results of aggregations”, in ISO/IEC 9075-2.

Function

Specify the result data type of the result of an aggregation over values of compatible data types, such as <case expression>s, <collection value expression>s, or a column in the result of a <query expression>.

Syntax Rules

- 1) Insert after SR 3)g) If any data type in *DTS* is DATALINK, then each data type in *DTS* shall be DATALINK and the result data type is DATALINK.

Access Rules

No additional Access Rules.

General Rules

No additional General Rules.

Conformance Rules

No additional Conformance Rules.

9.4 Type precedence list determination

This Subclause modifies Subclause 9.5, “Type precedence list determination”, in ISO/IEC 9075-2.

Function

Determine the type precedence list of a given type.

Syntax Rules

- 1) Insert this SR If *DT* specifies datalink, then *TPL* is
 DATALINK

Access Rules

No additional Access Rules.

General Rules

No additional General Rules.

Conformance Rules

No additional Conformance Rules.

9.5 Determination of identical values

This Subclause modifies Subclause 9.8, “Determination of identical values”, in ISO/IEC 9075-2.

Function

Determine whether two instances of values are identical, that is to say, are occurrences of the same value.

Syntax Rules

No additional Syntax Rules.

Access Rules

No additional Access Rules.

General Rules

- 1) Insert after GR 2)a) If *V1* and *V2* are datalinks, then *V1* is identical to *V2* if and only if the File Reference of *V1* is identical to the File Reference of *V2* and the SQL-Mediated Access Indication of *V1* is identical to the SQL-Mediated Access Indication of *V2*.

Conformance Rules

No additional Conformance Rules.

9.6 Equality operations

This Subclause modifies Subclause 9.9, “Equality operations”, in ISO/IEC 9075-2.

Function

Specify the prohibitions and restrictions by data type on operations that involve testing for equality.

Syntax Rules

- 1) Insert this SR The declared type of an operand of an equality operation shall not be DATALINK-ordered.

Access Rules

No additional Access Rules.

General Rules

No additional General Rules.

Conformance Rules

No additional Conformance Rules.

9.7 Grouping operations

This Subclause modifies Subclause 9.10, “Grouping operations”, in ISO/IEC 9075-2.

Function

Specify the prohibitions and restrictions by data type on operations that involve grouping of data.

Syntax Rules

- 1) Insert this SR The declared type of an operand of a grouping operation shall not be DATALINK-ordered.

Access Rules

No additional Access Rules.

General Rules

No additional General Rules.

Conformance Rules

No additional Conformance Rules.

9.8 Multiset element grouping operations

This Subclause modifies Subclause 9.11, “Multiset element grouping operations”, in ISO/IEC 9075-2.

Function

Specify the prohibitions and restrictions by data type on the declared element type of a multiset for operations that involve grouping the elements of a multiset.

Format

No additional Format items.

Syntax Rules

- 1) Insert this SR The declared element type of a multiset operand of a multiset element grouping operation shall not be DATALINK-ordered.

Access Rules

No additional Access Rules.

General Rules

No additional General Rules.

Conformance Rules

No additional Conformance Rules.

9.9 Ordering operations

This Subclause modifies Subclause 9.12, “Ordering operations”, in ISO/IEC 9075-2.

Function

Specify the prohibitions and restrictions by data type on operations that involve ordering of data.

Format

No additional Format items.

Syntax Rules

- 1) Insert this SR The declared type of an operand of an ordering operation shall not be DATALINK-ordered.

Access Rules

No additional Access Rules.

General Rules

No additional General Rules.

Conformance Rules

No additional Conformance Rules.

(Blank page)

10 Additional common elements

This Clause modifies Clause 10, “Additional common elements”, in ISO/IEC 9075-2.

10.1 <generic options>

Function

Specify a list of options identified by keywords.

Format

```
<generic options> ::= OPTIONS <left paren> <generic option list> <right paren>  
<generic option list> ::= <generic option> [ { <comma> <generic option> }... ]  
<generic option> ::= <option name> [ <option value> ]  
<option value> ::= <character string literal>
```

Syntax Rules

- 1) Let *GOPL* be the <generic option list>.
- 2) No two <generic option>s immediately contained in *GOPL* shall have the same <option name>.

NOTE 30 — The permissible values of <option name> and <option value> are defined by the foreign-data wrapper that deals with the object for which these generic options are being specified.

Access Rules

None.

General Rules

- 1) A generic options descriptor *GOPD* is created as follows. Let *n* be the number of <generic option>s contained in <generic option list> *GOPL*. For *i* ranging from 1 (one) to *n*, the *i*-th <option name> included in *GOPD* is the *i*-th <option name> contained in *GOPL* and the *i*-th option value included in *GOPD* is the *i*-th <option value> contained in *GOPL*, if any.

Conformance Rules

None.

10.2 <alter generic options>

Function

Change the contents of a generic options descriptor

Format

```
<alter generic options> ::=
OPTIONS <left paren> <alter generic option list> <right paren>

<alter generic option list> ::=
<alter generic option> [ { <comma> <alter generic option> }... ]

<alter generic option> ::= [ <alter operation> ] <option name> [ <option value> ]

<alter operation> ::=
ADD
| SET
| DROP
```

Syntax Rules

- 1) Let *GOPD* be the applicable generic options descriptor. Let *AGOPL* be the <alter generic option list>.
- 2) Let *m* be the number of <alter generic option>s immediately contained in *AGOPL*. For *j* ranging from 1 (one) to *m*:
 - a) Let *AGOP_j* be the *j*-th <alter generic option> immediately contained in *AGOPL*.
 - b) For each *AGOP_j*, if <alter operation> is omitted, then *ADD* is implicit.
 - c) Let *AOP_j* and *OPN_j* be the <alter operation> and <option name>, respectively, specified or implied by *AGOP_j*.

Case:

- i) If *AOP_j* is *ADD*, then:
 - 1) <option value> shall be specified and *GOPD* shall not include an <option name> that is equivalent to *OPN_j*.
 - 2) *AGOPL* shall not immediately contain any other <alter generic option> that immediately contains an <alter operation> that specifies or implies *ADD*, and an <option name> that is equivalent to *OPN_j*.
- ii) If *AOP_j* is *SET*, then <option value> shall be specified and *GOPD* shall include an <option name> that is equivalent to *OPN_j*.
- iii) Otherwise, <option value> shall not be specified and *GOPD* shall include an <option name> that is equivalent to *OPN_j*.

Access Rules

None.

General Rules

- 1) For each <alter generic option> *AGOP* contained in *AGOL*, let *AOP* and *OPN* be the <alter operation> and <option name>, respectively, specified or implied by *AGOP* and let *OPV* be the result of <option value> contained in *AGOP*.

Case:

- a) If *AOP* is ADD, then let *n* be the number of <option name>s included in *GOPD*. *OPN* is added as the *n*+1-th <option name> included in *GOPD* and *OPV* is added as the *n*+1-th <option value> included in *GOPD*.
- b) If *AOP* is SET, then let *i* be the ordinal position of *OPN* in *GOPD*. The *i*-th <option value> in *GOPD* is replaced by *OPV*.
- c) If *AOP* is DROP, then let *i* be the ordinal position of *OPN* in *GOPD*. The *i*-th <option name> and the *i*-th <option value> are removed from *GOPD*. The ordinal positions of all <option name>s and <option value>s having an ordinal position greater than *i* are reduced by 1 (one).

Conformance Rules

None.

(Blank page)

11 Schema definition and manipulation

This Clause modifies Clause 11, “Schema definition and manipulation”, in ISO/IEC 9075-2.

11.1 <schema definition>

This Subclause modifies Subclause 11.1, “<schema definition>”, in ISO/IEC 9075-2.

Function

Define a schema.

Format

```
<schema element> ::=  
!! All alternatives from ISO/IEC 9075-2  
| <foreign table definition>
```

Syntax Rules

No additional Syntax Rules.

Access Rules

No additional Access Rules.

General Rules

No additional General Rules.

Conformance Rules

No additional Conformance Rules.

11.2 <drop schema statement>

This Subclause modifies Subclause 11.2, “<drop schema statement>”, in ISO/IEC 9075-2.

Function

Destroy a schema.

Format

No additional Format items.

Syntax Rules

- 1) Replace SR 3) If RESTRICT is specified, then *S* shall not contain any persistent base tables, global temporary tables, created local temporary tables, foreign tables, views, domains, assertions, character sets, collations, transliterations, triggers, user-defined types, SQL-invoked routines, roles, or sequence generators, and the <schema name> of *S* shall not be generally contained in the SQL routine body of any routine descriptor.

NOTE 31 — If CASCADE is specified, then such objects will be dropped by the effective execution of the SQL schema manipulation statements specified in the General Rules of this Subclause.

Access Rules

No additional Access Rules.

General Rules

- 1) Replace GR 1) Let *T* be the <table name> included in the descriptor of any base table, foreign table, or temporary table included in *S*.

Case:

- a) If *T* is a base table or temporary table, then the following <drop table statement> is effectively executed:

```
DROP TABLE T CASCADE
```

- b) Otherwise, the following <drop foreign table statement> is effectively executed:

```
DROP FOREIGN TABLE T CASCADE
```

Conformance Rules

No additional Conformance Rules.

11.3 <table definition>

This Subclause modifies Subclause 11.3, “<table definition>”, in ISO/IEC 9075-2.

Function

Define a persistent base table, a created local temporary table, or a global temporary table.

Format

```
<column option list> ::=  
!! All options from ISO/IEC 9075-2 [ <datalink control definition> ]
```

Syntax Rules

- 1) Replace SR 8)g)iii) A <column option list> shall immediately contain either a <scope clause> or a <default clause>, or at least one <column constraint definition>, or a <datalink control definition>.
- 2) Insert after SR 8)g)vi) If *CO* specifies <datalink control definition> *DCS*, then let *COLN* be the <column name> contained in *RCD* followed in turn by the <data type> or <domain name> contained in *RCD*, the <default clause> (if any) contained in *RCD*, every <column constraint definition> contained in *RCD*, and *DCS*. *RCD* is replaced by *COLN*.

Access Rules

No additional Access Rules.

General Rules

- 1) Insert after GR 2) For each <column options> *CO*, if *CO* contains a <datalink control definition> *DCD*, then let *CD* be the column descriptor identified by the <column name> specified in *CO*. The link control options specified in *DCD* are included in the datalink data type descriptor that is included in *CD*.

Conformance Rules

No additional Conformance Rules.

11.4 <unique constraint definition>

This Subclause modifies Subclause 11.7, “<unique constraint definition>”, in ISO/IEC 9075-2.

Function

Specify a uniqueness constraint for a table.

Format

No additional Format items.

Syntax Rules

- 1) Insert after SR 1 The declared type of no column identified by any <column name> in the <unique column list> shall be DATALINK-ordered.

Access Rules

No additional Access Rules.

General Rules

No additional General Rules.

Conformance Rules

No additional Conformance Rules.

11.5 <check constraint definition>

This Subclause modifies Subclause 11.9, “<check constraint definition>”, in ISO/IEC 9075-2.

Function

Specify a condition for the SQL-data.

Format

No additional Format items.

Syntax Rules

- 1) Insert this SR The <search condition> shall not generally contain a <table reference> that references a foreign table.

Access Rules

No additional Access Rules.

General Rules

No additional General Rules.

Conformance Rules

No additional Conformance Rules.

11.6 <drop column definition>

This Subclause modifies Subclause 11.18, “<drop column definition>”, in ISO/IEC 9075-2.

Function

Destroy a column of a base table.

Format

No additional Format items.

Syntax Rules

No additional Syntax Rules.

Access Rules

No additional Access Rules.

General Rules

- 1) Insert after GR 2) For each row *R* of *T*, if the value of *C* in *R* is not null, then for every site *DLC* whose value is a constituent of the value of *C* and whose declared type is either DATALINK or some distinct type whose source type is DATALINK, let *EF* be the external file referenced by the value of *DLC*. If *EF* is linked, then *EF* is unlinked.

NOTE 32 — The effect of unlinking depends on the unlink control option, RESTORE or DELETE, included in the data type descriptor of *DLC*, as specified in Subclause 4.8, “Datalinks”.

NOTE 33 — “constituent” is defined in Subclause 4.9, “Columns, fields, and attributes”.

Conformance Rules

No additional Conformance Rules.

11.7 <domain definition>

This Subclause modifies Subclause 11.24, “<domain definition>”, in ISO/IEC 9075-2.

Function

Define a domain.

Format

No additional Format items.

Syntax Rules

- 1) Insert before SR 1 <data type> shall not contain a <datalink control definition>.

Access Rules

No additional Access Rules.

General Rules

No additional General Rules.

Conformance Rules

No additional Conformance Rules.

11.8 <assertion definition>

This Subclause modifies Subclause 11.37, “<assertion definition>”, in ISO/IEC 9075-2.

Function

Specify an integrity constraint.

Format

No additional Format items.

Syntax Rules

- 1) Insert this SR The <search condition> shall not generally contain a <table reference> that references a foreign table.

Access Rules

No additional Access Rules.

General Rules

No additional General Rules.

Conformance Rules

No additional Conformance Rules.

11.9 <user-defined type definition>

This Subclause modifies Subclause 11.41, “<user-defined type definition>”, in ISO/IEC 9075-2.

Function

Define a user-defined type.

Format

No additional Format items.

Syntax Rules

No additional Syntax Rules.

Access Rules

No additional Access Rules.

General Rules

- 1) Replace GR 2)c)i If *SDT* is neither a large object type nor a datalink type, then the following SQL-statement is executed without further Access Rule checking:

```
CREATE ORDERING FOR UDTN
ORDER FULL BY
  MAP WITH FUNCTION FNSDT(UDTN)
FOR UDTN
```

Conformance Rules

No additional Conformance Rules.

11.10 <SQL-invoked routine>

This Subclause modifies Subclause 11.50, “<SQL-invoked routine>”, in ISO/IEC 9075-2.

Function

Define an SQL-invoked routine.

Format

No additional Format items.

Syntax Rules

- 1) Insert before SR 1) Neither <returns type> nor <parameter type> shall contain a <datalink control definition>.

Access Rules

No additional Access Rules.

General Rules

No additional General Rules.

Conformance Rules

No additional Conformance Rules.

11.11 <drop routine statement>

This Subclause modifies Subclause 11.52, “<drop routine statement>”, in ISO/IEC 9075-2.

Function

Destroy an SQL-invoked routine.

Format

No additional Format items.

Syntax Rules

- 1) Insert after SR 5)b)ii) A routine mapping descriptor.

Access Rules

No additional Access Rules.

General Rules

- 1) Insert after GR 2) Let *RM* be any routine mapping descriptor that includes a specific routine name that is equivalent to *SN*. Let *RMN* be the routine mapping name included in *RM*. The following <drop routine mapping statement> is effectively executed without further Access Rule checking:

DROP ROUTINE MAPPING *RMN*

Conformance Rules

No additional Conformance Rules.

11.12 <user-defined cast definition>

This Subclause modifies Subclause 11.53, “<user-defined cast definition>”, in ISO/IEC 9075-2.

Function

Define a user-defined cast.

Format

No additional Format items.

Syntax Rules

- 1) Insert before SR 1) Neither <source data type> nor <target data type> shall contain a <datalink control definition>.

Access Rules

No additional Access Rules.

General Rules

No additional General Rules.

Conformance Rules

No additional Conformance Rules.

11.13 <user-defined ordering definition>

This Subclause modifies Subclause 11.55, “<user-defined ordering definition>”, in ISO/IEC 9075-2.

Function

Define a user-defined ordering for a user-defined type.

Format

No additional Format items.

Syntax Rules

- 1) Insert after SR 6)a)iii The declared type of each attribute of *UDT* shall not be DATALINK-ordered.

Access Rules

No additional Access Rules.

General Rules

No additional General Rules.

Conformance Rules

No additional Conformance Rules.

11.14 <foreign table definition>

Function

Define a foreign table.

Format

```
<foreign table definition> ::=  
CREATE FOREIGN TABLE <table name>  
[ <left paren> <basic column definition list> <right paren> ]  
SERVER <foreign server name> [ <table generic options> ]  
  
<table generic options> ::= <generic options>  
  
<basic column definition list> ::=  
<basic column definition> [ { <comma> <basic column definition> }... ]  
  
<basic column definition> ::= <column name> <data type> [ <column generic options> ]  
  
<column generic options> ::= <generic options>
```

Syntax Rules

- 1) If <foreign table definition> is contained in a <schema definition>, and if the <table name> contains a <schema name>, then that <schema name> shall be equivalent to the specified or implicit <schema name> of the containing <schema definition>.
- 2) Let *TN* be the <table name>. Let *S* be the schema identified by the explicit or implicit schema name of *TN*. *S* shall not include a table descriptor whose table name is equivalent to *TN*.
- 3) If <basic column definition list> is specified, then let *n* be the cardinality of the <basic column definition list>. For all *i*, $1 \text{ (one)} \leq i \leq n$:
 - a) For all *j*, $1 \text{ (one)} \leq j \leq n$, if the <column name> contained in the *i*-th <basic column definition> is equivalent to the <column name> contained in the *j*-th <basic column definition>, then $i=j$.
 - b) If the <data type> contained in the *i*-th <basic column definition> specifies a <character string type> and does not specify a <character set specification>, then the <character set specification> specified or implicit in the <schema character set specification> of the <schema definition> that created the schema *S* is implicit.
- 4) Let *FSN* be the <foreign server name>.
- 5) The catalog identified by the explicit or implicit catalog name of *FSN* shall include a foreign server descriptor whose foreign server name is equivalent to *FSN*.
- 6) If the <foreign table definition> is contained in a <schema definition> *SD*, then let *A* be the explicit or implicit <authorization identifier> of *SD*. Otherwise, let *A* be the <authorization identifier> that owns the schema identified by the implicit or explicit <schema name> of *TN*.

Access Rules

- 1) If <foreign table definition> is contained in an SQL-client module, then the enabled authorization identifiers shall include *A*.
- 2) The applicable privileges shall include the USAGE privilege on the foreign-server identified by <foreign server name>.
- 3) Additional privileges, if any, necessary to execute <foreign table definition> are implementation-defined.

General Rules

- 1) A foreign table descriptor *FTD* is created in *S*. *FTD* includes:
 - a) The table name *TN*.
 - b) The foreign server name *FSN*.
 - c) If <table generic options> *TGO* is specified, then the generic options descriptor created by *TGO*; otherwise, an empty generic options descriptor.
 - d) Case:
 - i) If <basic column definition list> *BCDL* is specified, then *n* column descriptors. For each <basic column definition> BCD_i , $1 \text{ (one)} \leq i \leq n$, the corresponding *i*-th column descriptor includes:
 - 1) The <column name> contained in BCD_i .
 - 2) An indication that the column name is not an implementation-dependent name.
 - 3) The data type descriptor of the <data type> *DT* simply contained in BCD_i .
 - 4) The ordinal position, *i*.
 - 5) The implementation-defined nullability characteristic.
 - 6) The implementation-defined <default option>.
 - 7) If <column generic options> *CGO* is specified, then the generic options descriptor created by *CGO*; otherwise, an empty generic options descriptor.
 - ii) Otherwise, the column descriptors included in *FTD* are implementation-defined.
 - e) An indication that the table is not referenceable.
 - f) An empty list of direct supertable names.
 - g) An empty list of direct subtable names.
 - h) An indication that the table is not insertable-into.
 - i) An indication that the table is not updatable.

NOTE 34 — This part of ISO/IEC 9075 currently restricts foreign tables such that they are neither insertable-into nor updatable. Future versions of this part of ISO/IEC 9075 may relax these restrictions.

- 2) Let T be the table described by FTD . Let m be the number of column descriptors CD_i , $1 \text{ (one)} \leq i \leq m$, included in FTD . The row type of T consists of m fields F_i such that, for all i , $1 \text{ (one)} \leq i \leq m$, the field name of F_i is the column name included in CD_i and the declared type of F_i is the data type described by the data type descriptor included in CD_i .
- 3) A set of privilege descriptors is created that define the privilege SELECT on T and SELECT for every column of T . These privileges are grantable. The grantor for each of these privilege descriptors is set to the special grantor value “_SYSTEM”. The grantee is A .

Conformance Rules

- 1) Without Feature M004, “Foreign data support”, conforming SQL language shall not contain a <foreign table definition>.

11.15 <alter foreign table statement>

Function

Change the definition of a foreign table.

Format

```
<alter foreign table statement> ::=  
ALTER FOREIGN TABLE <table name> <alter foreign table action>  
  
<alter foreign table action> ::=  
<add basic column definition>  
| <alter basic column definition>  
| <drop basic column definition>  
| <alter generic options>
```

Syntax Rules

- 1) The schema *S* identified by the explicit or implicit schema name of the <table name> *TN* shall include a foreign table descriptor *FTD* whose table name is equivalent to *TN*. *FTD* is the descriptor of the foreign table being altered.
- 2) Let *A* be the <authorization identifier> that owns the schema identified by the <schema name> of the table identified by *TN*.
- 3) If <alter generic options> *AGO* is specified, then the Syntax Rules of Subclause 10.2, “<alter generic options>”, are applied to *AGO* with the generic options descriptor included in *FTD* as the applicable generic options descriptor.

Access Rules

- 1) The enabled authorization identifiers shall include *A*.

General Rules

- 1) *FTD* is modified as specified by <alter foreign table action>.
- 2) If <alter generic options> *AGO* is specified, then the General Rules of Subclause 10.2, “<alter generic options>”, are applied to *AGO* with the generic options descriptor included in *FTD* as the applicable generic options descriptor.
- 3) If <alter generic options> is specified, any effect on *FTD*, apart from that on its generic options descriptor, is implementation-defined.
- 4) Let *T* be the table described by *FTD*. Let *m* be the number of column descriptors CD_i , $1 \text{ (one)} \leq i \leq m$, included in *FTD*. The row type of *T* consists of *m* fields F_i such that, for all *i*, $1 \text{ (one)} \leq i \leq m$, the field name of F_i is the column name included in CD_i and the declared type of F_i is the data type described by the data type descriptor included in CD_i .

Conformance Rules

- 1) Without Feature M004, “Foreign data support”, conforming SQL language shall not contain an <alter foreign table statement>.

11.16 <add basic column definition>

Function

Add a column to a foreign table.

Format

<add basic column definition> ::= ADD [COLUMN] <basic column definition>

Syntax Rules

- 1) Let *FTD* be the descriptor of the foreign table being altered.
- 2) *FTD* shall not include a column descriptor whose column name is equivalent to the <column name> *CN* specified in the <basic column definition> *BCD*.
- 3) Let *A* be the <authorization identifier> that owns the schema that includes *FTD*.

Access Rules

None.

General Rules

- 1) Let *n* be the number of column descriptors included in *FTD*.
- 2) The degree of the table being altered by the containing <alter foreign table statement> is increased by 1 (one).
- 3) A column descriptor *CD* is added to *FTD*. *CD* includes:
 - a) The <column name> *CN* contained in *BCD*.
 - b) An indication that the column name is not an implementation-dependent name.
 - c) The data type descriptor of the <data type> *DT* simply contained in *BCD*.
 - d) The ordinal position, *n+1*.
 - e) The implementation-defined nullability characteristic.
 - f) The implementation-defined <default option>.
 - g) If <column generic options> *CGO* is specified, then the generic options descriptor created by *CGO*; otherwise, an empty generic options descriptor.
- 4) Let *T* be the table described by *FTD*. For every table privilege descriptor that specifies *T* and a privilege of SELECT, a new column privilege descriptor is created that specifies *T*, the same action, grantor, and grantee, and the same grantability, and specifies *CN*.

CD ISO/IEC 9075-9:2007 (E)
11.16 <add basic column definition>

Conformance Rules

None.

11.17 <alter basic column definition>

Function

Change the definition of a column of a foreign table.

Format

```
<alter basic column definition> ::=  
ALTER [ COLUMN ] <column name> <alter basic column action>  
  
<alter basic column action> ::= <alter generic options>
```

Syntax Rules

- 1) Let *FTD* be the descriptor of the foreign table identified in the containing <alter table statement>.
- 2) *FTD* shall include a column descriptor *CD* whose column name is equivalent to <column name>.
- 3) Let *C* be the column described by *CD*.

Access Rules

None.

General Rules

- 1) *CD* is modified as specified by <alter basic column action>.
- 2) If <alter generic options> is specified, any effect on *CD*, apart from that on its generic options descriptor, is implementation-defined.

Conformance Rules

None.

11.18 <drop basic column definition>

Function

Destroy a column of a foreign table.

Format

<drop basic column definition> ::= DROP [COLUMN] <column name> <drop behavior>

Syntax Rules

- 1) Let *FTD* be the descriptor of the foreign table being altered.
- 2) *FTD* shall include a column descriptor *CD* whose column name is equivalent to the <column name> *CN*.
- 3) *FTD* shall include at least two column descriptors.
- 4) Let *C* be the column described by *CD*.
- 5) If RESTRICT is specified, then *C* shall not be referenced in any of the following:
 - a) The <query expression> of any view descriptor.
 - b) The <search condition> of any constraint descriptor.
 - c) The <SQL routine body> of any routine descriptor.
 - d) Either an explicit trigger column list or a triggered action column set of any trigger descriptor.

NOTE 35 — A <drop basic column definition> that does not specify CASCADE will fail if there are any references to that column resulting from the use of CORRESPONDING, NATURAL, or SELECT * (except where contained in an exists predicate).

NOTE 36 — If CASCADE is specified, then any such dependent object will be dropped by the execution of the <revoke statement> specified in the General Rules of this Subclause.

NOTE 37 — *CN* may be contained in an implicit trigger column list of a trigger descriptor.

Access Rules

None.

General Rules

- 1) Let *TR* be the trigger name of any trigger descriptor having an explicit trigger column list or a triggered action column set that contains *CN*. The following <drop trigger statement> is effectively executed without further Access Rule checking:

```
DROP TRIGGER TR
```

- 2) Let *A* be the <authorization identifier> that owns *T*. The following <revoke statement> is effectively executed with a current authorization identifier of “_SYSTEM” and without further Access Rule checking:

REVOKE SELECT(*CN*) ON TABLE *TN* FROM A CASCADE

- 3) Let *R* be any SQL-invoked routine whose routine descriptor contains *CN* in the <SQL routine body>. Let *SN* be the <specific name> of *R*. The following <drop routine statement> is effectively executed for every *R* without further Access Rule checking:

DROP SPECIFIC ROUTINE *SN* CASCADE

- 4) *CD* is destroyed and the ordinal position of every column descriptor following *CD* in *FTD* is reduced by 1 (one).
- 5) The degree of the table described by *FTD* is reduced by 1 (one).

Conformance Rules

None.

11.19 <drop foreign table statement>

Function

Destroy a foreign table.

Format

<drop foreign table statement> ::= DROP FOREIGN TABLE <table name> <drop behavior>

Syntax Rules

- 1) The schema *S* identified by the explicit or implicit schema name of the <table name> *TN* shall include a foreign table descriptor *FTD* whose table name is equivalent to *TN*. Let *T* be the table described by *FTD*.
- 2) If RESTRICT is specified, then *T* shall not be referenced in any of the following:
 - a) The <query expression> of any view descriptor.
 - b) The <SQL routine body> of any SQL-invoked routine descriptor.
 - c) The trigger action of any trigger descriptor.

NOTE 38 — If CASCADE is specified, then such referenced objects will be dropped by the execution of the <revoke statement> specified in the General Rules of this Subclause.

Access Rules

- 1) The enabled authorization identifiers shall include the <authorization identifier> that owns *S*.

General Rules

- 1) Every row of *T* is effectively deleted at the end of the SQL-statement, prior to the checking of any integrity constraints.

NOTE 39 — This deletion creates neither a new trigger execution context nor the definition of a new state change in the current trigger execution context.

- 2) The following <revoke statement> is effectively executed with a current authorization identifier of “_SYSTEM” and without further Access Rule checking:

```
REVOKE ALL PRIVILEGES ON TN FROM A CASCADE
```

- 3) Let *R* be any SQL-invoked routine whose routine descriptor contains *TN* in the <SQL routine body>. Let *SN* be the <specific name> of *R*. The following <drop routine statement> is effectively executed without further Access Rule checking:

```
DROP SPECIFIC ROUTINE SN CASCADE
```

- 4) *FTD* is destroyed.

Conformance Rules

- 1) Without Feature M004, “Foreign data support”, conforming SQL language shall not contain a <drop foreign table statement>.

(Blank page)

12 Catalog manipulation

12.1 <foreign server definition>

Function

Define a foreign server.

Format

```
<foreign server definition> ::=  
CREATE SERVER <foreign server name>  
[ TYPE <server type> ] [ VERSION <server version> ]  
FOREIGN DATA WRAPPER <foreign-data wrapper name> [ <generic options> ]  
  
<server type> ::= !! See the Syntax Rules  
  
<server version> ::= !! See the Syntax Rules
```

Syntax Rules

- 1) Let *FSN* be the <foreign server name>. Let *CI* be the catalog identified by the explicit or implicit catalog name of *FSN*. *CI* shall not include a foreign server descriptor whose foreign server name is equivalent to *FSN*.
- 2) Let *WN* be the <foreign-data wrapper name>. Let *C2* be the catalog identified by the explicit or implicit catalog name of *WN*. *C2* shall include a foreign-data wrapper descriptor whose foreign-data wrapper name is *WN*.
- 3) The permissible Format and values for <server type> and <server version> are implementation-defined.

Access Rules

- 1) The applicable privileges shall include the USAGE privilege on the foreign-data wrapper identified by <foreign-data wrapper name>.
- 2) Additional privileges, if any, necessary to execute <foreign server definition> are implementation-defined.

General Rules

- 1) A foreign server descriptor *FSD* is created. *FSD* includes:
 - a) The foreign server name *FSN*.

CD ISO/IEC 9075-9:2007 (E)

12.1 <foreign server definition>

- b) The foreign-data wrapper name *WN*.
 - c) The <server type>, if specified.
 - d) The <server version>, if specified.
 - e) The current authorization identifier.
 - f) If <generic options> *GO* is specified, then the generic options descriptor created by *GO*; otherwise, an empty generic options descriptor.
- 2) A privilege descriptor is created that defines the USAGE privilege on this foreign server to the current authorization identifier>. The grantor of the privilege descriptor is set to the special grantor value “_SYSTEM”. This privilege is grantable.

Conformance Rules

- 1) Without Feature M004, “Foreign data support”, conforming SQL language shall not contain a <foreign server definition>.

12.2 <alter foreign server statement>

Function

Change the definition of a foreign server.

Format

```
<alter foreign server statement> ::=  
ALTER SERVER <foreign server name> [ <new version> ] [ <alter generic options> ]  
  
<new version> ::= VERSION <server version>
```

Syntax Rules

- 1) If <new version> is not specified, then <alter generic options> shall be specified.
- 2) If <alter generic options> is not specified, then <new version> shall be specified.
- 3) Let *FSN* be the <foreign server name>. Let *C* be the catalog identified by the explicit or implicit catalog name of *FSN*. *C* shall include a foreign server descriptor *FSD* whose foreign server name is equivalent to *FSN*.
- 4) If <alter generic options> *AGO* is specified, then the Syntax Rules of [Subclause 10.2](#), “<alter generic options>”, are applied to *AGO* with the generic options descriptor included in *FSD* as the applicable generic options descriptor.
- 5) Let *A* be the authorization identifier that owns the foreign server descriptor identified by *FSN*.

Access Rules

- 1) The enabled authorization identifiers shall include *A*.

General Rules

- 1) If <new version> *NV* is specified, then the <server version> included in *FSD* is the <server version> specified in *NV*.
- 2) If <alter generic options> *AGO* is specified, then the General Rules of [Subclause 10.2](#), “<alter generic options>”, are applied to *AGO* with the generic options descriptor included in *FSD* as the applicable generic options descriptor.

Conformance Rules

- 1) Without Feature M004, “Foreign data support”, conforming SQL language shall not contain an <alter foreign server statement>.

12.3 <drop foreign server statement>

Function

Destroy a foreign server descriptor.

Format

<drop foreign server statement> ::= DROP SERVER <foreign server name> <drop behavior>

Syntax Rules

- 1) Let *FSN* be the <foreign server name>. Let *C* be the catalog identified by the explicit or implicit catalog name of *FSN*. *C* shall include a foreign server descriptor *S* whose foreign server name is equivalent to *FSN*.
- 2) If <drop behavior> specifies RESTRICT, then *S* shall not be referenced by any of the following:
 - a) A foreign table descriptor.
 - b) A routine mapping descriptor.
 - c) A user mapping descriptor.
- 3) Let *A* be the authorization identifier that owns the foreign server descriptor identified by *FSN*.

Access Rules

- 1) The enabled authorization identifiers shall include *A*.

General Rules

- 1) Let *UM* be any user mapping descriptor that includes a foreign server name that is equivalent to *FSN*. Let *AI* be the authorization identifier included in *UM*. The following <drop user mapping statement> is effectively executed without further Access Rule checking:
DROP USER MAPPING FOR *AI* SERVER *FSN*
- 2) Let *RM* be any routine mapping descriptor that includes a foreign server name that is equivalent to *FSN*. Let *RMN* be the routine mapping name included in *RM*. The following <drop routine mapping statement> is effectively executed without further Access Rule checking:
DROP ROUTINE MAPPING *RMN*
- 3) The following <revoke statement> is effectively executed with a current authorization identifier of “_SYSTEM” and without further Access Rule checking:
REVOKE ALL PRIVILEGES ON *FSN* FROM A CASCADE
- 4) The descriptor *S* is destroyed.

Conformance Rules

- 1) Without Feature M004, “Foreign data support”, conforming SQL language shall not contain a <drop foreign server statement>.

12.4 <foreign-data wrapper definition>

Function

Define a foreign-data wrapper

Format

```
<foreign-data wrapper definition> ::=  
CREATE FOREIGN DATA WRAPPER <foreign-data wrapper name>  
[ <library name specification> ] <language clause> [ <generic options> ]  
  
<library name specification> ::= LIBRARY <library name>  
  
<library name> ::= <character string literal>
```

Syntax Rules

- 1) Let *WN* be the <foreign-data wrapper name>. Let *C* be the catalog identified by the explicit or implicit catalog name of *WN*. *C* shall not include a foreign-data wrapper descriptor whose foreign-data wrapper name is equivalent to *WN*.
- 2) If <library name specification> is not specified, then a <library name specification> with an implementation-dependent <library name> is implicit.

Access Rules

- 1) The privileges necessary to execute <foreign-data wrapper definition> are implementation-defined.

General Rules

- 1) A foreign-data wrapper descriptor *WD* is created. *WD* includes:
 - a) The foreign-data wrapper name *WN*.
 - b) The current authorization identifier.
 - c) The implicit or explicit <library name>.
 - d) The name of the language specified in <language clause>.
 - e) If <generic options> *GO* is specified, then the generic options descriptor created by *GO*; otherwise, an empty generic options descriptor.
- 2) A privilege descriptor is created that defines the USAGE privilege on this foreign-data wrapper to the current authorization identifier. The grantor of the privilege descriptor is set to the special grantor value “_SYSTEM”. This privilege is grantable.

Conformance Rules

- 1) Without Feature M004, “Foreign data support”, conforming SQL language shall not contain a <foreign-data wrapper definition>.

12.5 <alter foreign-data wrapper statement>

Function

Change the definition of a foreign-data wrapper.

Format

```
<alter foreign-data wrapper statement> ::=  
ALTER FOREIGN DATA WRAPPER <foreign-data wrapper name>  
[ <library name specification> ] [ <alter generic options> ]
```

Syntax Rules

- 1) Let *WN* be the <foreign-data wrapper name>. Let *C* be the catalog identified by the explicit or implicit catalog name of *FSN*. *C* shall include a foreign-data wrapper descriptor *W* whose foreign-data wrapper name is equivalent to *WN*.
- 2) If <library name specification> is not specified, then <alter generic options> shall be specified.
- 3) If <alter generic options> is not specified, then <library name specification> shall be specified.
- 4) If <alter generic options> *AGO* is specified, then the Syntax Rules of [Subclause 10.2](#), “<alter generic options>”, are applied to *AGO* with the generic options descriptor included in *W* as the applicable generic options descriptor.
- 5) Let *A* be the authorization identifier that owns the foreign-data wrapper descriptor identified by *WN*.

Access Rules

- 1) The enabled authorization identifiers shall include *A*.

General Rules

- 1) If <library name specification> is specified, then the <library name> is included in *W*, replacing any existing <library name>.
- 2) If <alter generic options> *AGO* is specified, then the General Rules of [Subclause 10.2](#), “<alter generic options>”, are applied to *AGO* with the generic options descriptor included in *W* as the applicable generic options descriptor.

Conformance Rules

- 1) Without Feature M004, “Foreign data support”, conforming SQL language shall not contain an <alter foreign-data wrapper statement>.

12.6 <drop foreign-data wrapper statement>

Function

Destroy a foreign-data wrapper.

Format

```
<drop foreign-data wrapper statement> ::=  
DROP FOREIGN DATA WRAPPER <foreign-data wrapper name> <drop behavior>
```

Syntax Rules

- 1) Let *WN* be the <foreign-data wrapper name>. Let *C* be the catalog identified by the explicit or implicit catalog name of *FSN*. *C* shall include a foreign-data wrapper descriptor *W* whose foreign-data wrapper name is equivalent to *WN*.
- 2) If <drop behavior> specifies RESTRICT, then *W* shall not be referenced by the foreign server name included in any foreign server descriptor.
- 3) Let *A* be the authorization identifier that owns the foreign-data wrapper descriptor identified by *WN*.

Access Rules

- 1) The enabled authorization identifiers shall include *A*.

General Rules

- 1) The following <revoke statement> is effectively executed with a current authorization identifier of “_SYSTEM” and without further Access Rule checking:

```
REVOKE ALL PRIVILEGES ON WN FROM A CASCADE
```

- 2) The descriptor of *W* is destroyed.

Conformance Rules

- 1) Without Feature M004, “Foreign data support”, conforming SQL language shall not contain a <drop foreign-data wrapper statement>.

12.7 <import foreign schema statement>

Function

Acquire information about some or all foreign tables associated with a schema managed by a foreign server.

Format

```

<import foreign schema statement> ::=
IMPORT FOREIGN SCHEMA <foreign schema name> [ <import qualifications> ]
FROM SERVER <foreign server name> INTO <local schema name>

<import qualifications> ::=
LIMIT TO <left paren> <table name list> <right paren>
| EXCEPT <left paren> <table name list> <right paren>

<table name list> ::= <table name> [ { <comma> <table name> }... ]

<foreign schema name> ::= <schema name>

<local schema name> ::= <schema name>

```

Syntax Rules

- 1) Let *FSN* be <foreign schema name>.
- 2) For every <table name> *TN* contained in <table name list>:
 - a) If *TN* specifies a <schema name> *SN*, then *SN* shall be equivalent to *FSN*.
 - b) Otherwise, a <schema name> that is equivalent to *FSN* is implicit.
- 3) There shall be an SQL-schema identified by <local schema name> *LSN*.

Access Rules

None.

General Rules

- 1) If the foreign server *FSVR* identified by <foreign server name> *FSVRN* does not maintain information analogous to schemas, or if the foreign-data wrapper by which the SQL-server accesses *FSVR* does not support schema importation, then an exception condition is raised: *FDW-specific condition — no schemas*.
- 2) If *FSVR* does not maintain information about a schema *FS* whose name is equivalent to *FSN*, then an exception condition is raised: *FDW-specific condition — schema not found*.
- 3) Case:
 - a) If <import qualifications> is not specified, then let *ITNL* be a <table name list> that contains the <table name> of every table associated with *FS*.

- b) If <import qualifications> specifies LIMIT TO, then let *ITNL* be the explicit <table name list>.
- c) If <import qualifications> specifies EXCEPT, then let *ITNL* be a <table name list> that contains the <table name> of every table associated with *FS* except the tables whose names are specified in the explicit <table name list>.
- 4) For every <table name> *FTN* contained in *ITNL*, if *FS* does not include a descriptor of a table whose <table name> is equivalent to *FTN*, then an exception condition is raised: *FDW-specific condition — table not found*.
- 5) For every <table name> *FTN* contained in *ITNL*:
 - a) Let *n* be the number of columns whose descriptors are included in the table identified by *FTN*.
 - b) Let BCD_i , $1 \text{ (one)} \leq i \leq n$, be a <basic column definition> that contains a <column name> equivalent to the name of the *i*-th column *COL* of the table identified by *FTN*, a <data type> corresponding to the data type of *COL*, and implementation-defined <column generic options>.
 - c) Let *FTD* be a <foreign table definition> that contains *FTN*, every BCD_i , $1 \text{ (one)} \leq i \leq n$, in sequence, separated by <comma>s, *FSVRN*, and implementation-defined <table generic options>.
 - d) *FTD* is effectively executed.

Conformance Rules

- 1) Without Feature M004, “Foreign data support”, conforming SQL language shall not contain an <import foreign schema statement>.
- 2) Without Feature M005, “Foreign schema support”, conforming SQL language shall not specify <import foreign schema statement>.

12.8 <routine mapping definition>

Function

Define a routine mapping.

Format

```
<routine mapping definition> ::=  
CREATE ROUTINE MAPPING <routine mapping name> FOR <specific routine designator>  
SERVER <foreign server name> [ <generic options> ]
```

Syntax Rules

- 1) Let *FSN* be the <foreign server name>. Let *RMN* be the <routine mapping name>.
- 2) The catalog identified by the explicit or implicit catalog name of *FSN* shall include a foreign server descriptor whose foreign server name is equivalent to *FSN*.
- 3) The SQL-environment shall not include a routine mapping descriptor whose routine mapping name is *RMN*.
- 4) Let *R* be the SQL-invoked routine identified by the <specific routine designator>. *R* shall identify an SQL-invoked regular function.
- 5) Let *SRN* be the <specific name> of *R*.
- 6) The SQL-environment shall not include a routine mapping descriptor whose specific routine name is *SRN* and whose foreign server name is *FSN*.

Access Rules

- 1) The applicable privileges shall include the USAGE privilege on the foreign server identified by *FSN*.
- 2) Additional privileges, if any, necessary to execute <routine mapping definition> are implementation-defined.

General Rules

- 1) A routine mapping descriptor *RMD* is created. *RMD* includes:
 - a) The routine mapping name *RMN*.
 - b) The specific routine name *SRN*.
 - c) The foreign server name *FSN*.
 - d) If <generic options> *GO* is specified, then the generic options descriptor created by *GO*; otherwise, an empty generic options descriptor.

Conformance Rules

- 1) Without Feature M004, “Foreign data support”, conforming SQL language shall not contain a <routine mapping definition>.

12.9 <alter routine mapping statement>

Function

Change the definition of a routine mapping.

Format

```
<alter routine mapping statement> ::=  
ALTER ROUTINE MAPPING <routine mapping name> <alter generic options>
```

Syntax Rules

- 1) Let *RMN* be the <routine mapping name> and let *AGO* be the <alter generic options>.
- 2) The SQL-environment shall include a routine mapping descriptor *RMD* whose routine mapping name is *RMN*.
- 3) The Syntax Rules of [Subclause 10.2](#), “<alter generic options>”, are applied to *AGO* with the generic options descriptor included in *RMD* as the applicable generic options descriptor.

Access Rules

- 1) The privileges necessary to execute <alter routine mapping statement> are implementation-defined.

General Rules

- 1) The General Rules of [Subclause 10.2](#), “<alter generic options>”, are applied to *AGO* with the generic options descriptor included in *RMD* as the applicable generic options descriptor.

Conformance Rules

- 1) Without Feature M004, “Foreign data support”, conforming SQL language shall not contain an <alter routine mapping statement>.

12.10 <drop routine mapping statement>

Function

Destroy a routine mapping.

Format

<drop routine mapping statement> ::= DROP ROUTINE MAPPING <routine mapping name>

Syntax Rules

- 1) Let *RMN* be the <routine mapping name>.
- 2) The SQL-environment shall include a routine mapping descriptor *RMD* whose routine mapping name is *RMN*.

Access Rules

- 1) The privileges necessary to execute <drop routine mapping statement> are implementation-defined.

General Rules

- 1) *RMD* is destroyed.

Conformance Rules

- 1) Without Feature M004, “Foreign data support”, conforming SQL language shall not contain a <drop routine mapping statement>.

(Blank page)

13 Access control

This Clause modifies Clause 12, “Access control”, in ISO/IEC 9075-2.

13.1 <privileges>

This Subclause modifies Subclause 12.3, “<privileges>”, in ISO/IEC 9075-2.

Function

Specify privileges.

Format

```
<object name> ::=  
!! All alternatives from ISO/IEC 9075-2  
| FOREIGN DATA WRAPPER <foreign-data wrapper name>  
| FOREIGN SERVER <foreign server name>
```

Syntax Rules

- 1) Augment SR 3 Add <foreign server name> and <foreign-data wrapper name> to the list of <object name>s that shall require the specification of USAGE.

Access Rules

No additional Access Rules.

General Rules

No additional General Rules.

Conformance Rules

No additional Conformance Rules.

13.2 <revoke statement>

This Subclause modifies Subclause 12.7, “<revoke statement>”, in ISO/IEC 9075-2.

Function

Destroy privileges and role authorizations.

Format

No additional Format items.

Syntax Rules

No additional Syntax Rules.

Access Rules

No additional Access Rules.

General Rules

- 1) Insert after GR 16 Let *T* be any foreign table descriptor included in *SI*. *T* is said to be *abandoned* if the revoke destruction action would result in *AI* no longer having USAGE privilege on the foreign server associated with the foreign table described by *T*.
- 2) Insert after GR 30 Let *FS* be any foreign server descriptor. *FS* is said to be *abandoned* if the revoke destruction action would result in *AI* no longer having USAGE privilege on the foreign-data wrapper associated with the foreign server described by *FS*.
- 3) Augment GR 31 Add abandoned foreign server descriptor and abandoned foreign table descriptor to the list of objects whose existence would cause an exception condition to be raised: *dependent privilege descriptors still exist*.
- 4) Insert this GR For every abandoned foreign server descriptor *FS*, let *FSN* be the <foreign server name> of *FS*. The following <drop foreign server statement> is effectively executed without further Access Rule checking:

```
DROP SERVER FSN CASCADE
```
- 5) Insert this GR For every abandoned foreign table descriptor *FT*, let *FTN* be the <table name> of *FT*. The following <drop foreign table statement> is effectively executed without further Access Rule checking:

```
DROP FOREIGN TABLE SI.FTN CASCADE
```

Conformance Rules

No additional Conformance Rules.

13.3 <user mapping definition>

Function

Define the mapping of an authorization identifier to a foreign server.

Format

```
<user mapping definition> ::=  
CREATE USER MAPPING FOR <specific or generic authorization identifier>  
SERVER <foreign server name> [ <generic options> ]  
  
<specific or generic authorization identifier> ::=  
<authorization identifier>  
| USER  
| CURRENT_USER  
| PUBLIC
```

Syntax Rules

- 1) Let *FSN* be the <foreign server name>. If <authorization identifier> is specified, then let *U* be the <authorization identifier>; if PUBLIC is specified, then let *U* be PUBLIC; otherwise, let *U* be the current authorization identifier.
- 2) The SQL-environment shall not include a user mapping descriptor whose authorization identifier is *U* and whose foreign server name is equivalent to *FSN*.
- 3) The catalog identified by the explicit or implicit catalog name of *FSN* shall include a foreign server descriptor whose foreign server name is equivalent to *FSN*.

Access Rules

- 1) The applicable privileges shall include the USAGE privilege on the foreign server identified by *FSN*.
- 2) Additional privileges, if any, necessary to execute <user mapping definition> are implementation-defined.

General Rules

- 1) A user mapping descriptor *UMD* is created. *UMD* includes:
 - a) Case:
 - i) If <specific or generic authorization identifier> specifies PUBLIC, then PUBLIC.
 - ii) Otherwise, the authorization identifier *U*.
 - b) The foreign server name *FSN*.
 - c) If <generic options> *GO* is specified, then the generic options descriptor created by *GO*; otherwise, an empty generic options descriptor.

Conformance Rules

- 1) Without Feature M004, “Foreign data support”, conforming SQL language shall not contain a <user mapping definition>.

13.4 <alter user mapping statement>

Function

Change the definition of a user mapping.

Format

```
<alter user mapping statement> ::=  
ALTER USER MAPPING <specific or generic authorization identifier>  
SERVER <foreign server name> <alter generic options>
```

Syntax Rules

- 1) Let *FSN* be the <foreign server name> and let *AGO* be the <alter generic options>. If <authorization identifier> is specified, then let *U* be the <authorization identifier>; if PUBLIC is specified, then let *U* be PUBLIC; otherwise, let *U* be the current authorization identifier.
- 2) The SQL-environment shall include a user mapping descriptor *UMD* whose authorization identifier is *U* and whose foreign server name is equivalent to *FSN*.
- 3) The Syntax Rules of Subclause 10.2, “<alter generic options>”, are applied to *AGO* with the generic options descriptor included in *UMD* as the applicable generic options descriptor.

Access Rules

- 1) The privileges necessary to execute <alter user mapping statement> are implementation-defined.

General Rules

- 1) The General Rules of Subclause 10.2, “<alter generic options>”, are applied to *AGO* with the generic options descriptor included in *UMD* as the applicable generic options descriptor.

Conformance Rules

- 1) Without Feature M004, “Foreign data support”, conforming SQL language shall not contain an <alter user mapping statement>.

13.5 <drop user mapping statement>

Function

Destroy a user mapping.

Format

```
<drop user mapping statement> ::=  
DROP USER MAPPING FOR <specific or generic authorization identifier>  
SERVER <foreign server name>
```

Syntax Rules

- 1) Let *FSN* be the <foreign server name>. If <authorization identifier> is specified, then let *U* be the <authorization identifier>; if PUBLIC is specified, then let *U* be PUBLIC; otherwise, let *U* be the current authorization identifier.
- 2) The SQL-environment shall include a user mapping descriptor *UMD* whose authorization identifier is *U* and whose foreign server name is equivalent to *FSN*.

Access Rules

- 1) The privileges necessary to execute <drop user mapping statement> are implementation-defined.

General Rules

- 1) *UMD* is destroyed.

Conformance Rules

- 1) Without Feature M004, “Foreign data support”, conforming SQL language shall not contain a <drop user mapping statement>.

(Blank page)

14 SQL-client modules

This Clause modifies Clause 13, “SQL-client modules”, in ISO/IEC 9075-2.

14.1 <SQL-client module definition>

This Subclause modifies Subclause 13.1, “<SQL-client module definition>”, in ISO/IEC 9075-2.

Function

Define an SQL-client module.

Format

No additional Format items.

Syntax Rules

No additional Syntax Rules.

Access Rules

No additional Access Rules.

General Rules

- 1) Insert after GR 4)a) If the SQL-session context of any of the SQL-sessions associated with the SQL-agent include {foreign server name : FSConnectionHandle} pairs, then for each such pair:
 - a) Let *CH* be the FSConnectionHandle.
 - b) The FreeFSConnection() routine is invoked with *CH* as the argument.
- 2) Insert after GR 4)a) If the SQL-session context of any of the SQL-sessions associated with the SQL-agent include {foreign-data wrapper name : WrapperEnvHandle} pairs, then for each such pair:
 - a) Let *EH* be the WrapperEnvHandle.
 - b) The FreeWrapperEnv() routine is invoked with *EH* as the argument.

Conformance Rules

No additional Conformance Rules.

14.2 <externally-invoked procedure>

This Subclause modifies Subclause 13.3, “<externally-invoked procedure>”, in ISO/IEC 9075-2.

Function

Define an externally-invoked procedure.

Format

No additional Format items.

Syntax Rules

- 1) Insert before SR 1) <host parameter data type> shall not contain a <datalink control definition>.

Access Rules

No additional Access Rules.

General Rules

No additional General Rules.

Conformance Rules

No additional Conformance Rules.

14.3 Calls to an <externally-invoked procedure>

This Subclause modifies Subclause 13.4, “Calls to an <externally-invoked procedure>”, in ISO/IEC 9075-2.

Function

Define the call to an <externally-invoked procedure> by an SQL-agent.

Syntax Rules

1) Insert into SR 2e)

```

DATA_EXCEPTION_DATALINK_VALUE_EXCEEDS_MAXIMUM_LENGTH:
    constant SQLSTATE_TYPE := "2201D";
DATA_EXCEPTION_INVALID_DATA_SPECIFIED_FOR_DATALINK:
    constant SQLSTATE_TYPE := "22017";
DATA_EXCEPTION_NULL_ARGUMENT_PASSED_TO_DATALINK_CONSTRUCTOR:
    constant SQLSTATE_TYPE := "2201A";
DATALINK_EXCEPTION_NO_SUBCLASS:
    constant SQLSTATE_TYPE := "HW000";
DATALINK_EXCEPTION_EXTERNAL_FILE_NOT_LINKED:
    constant SQLSTATE_TYPE := "HW001";
DATALINK_EXCEPTION_EXTERNAL_FILE_ALREADY_LINKED:
    constant SQLSTATE_TYPE := "HW002";
DATALINK_EXCEPTION_INVALID_WRITE_TOKEN:
    constant SQLSTATE_TYPE := "HW004";
DATALINK_EXCEPTION_INVALID_DATALINK_CONSTRUCTION:
    constant SQLSTATE_TYPE := "HW005";
DATALINK_EXCEPTION_INVALID_WRITE_PERMISSION_FOR_UPDATE:
    constant SQLSTATE_TYPE := "HW006";
DATALINK_EXCEPTION_REFERENCED_FILE_DOES_NOT_EXIST:
    constant SQLSTATE_TYPE := "HW003";
DATALINK_EXCEPTION_REFERENCED_FILE_NOT_VALID:
    constant SQLSTATE_TYPE := "HW007";
FDW_SPECIFIC_CONDITION_NO_SUBCLASS:
    constant SQLSTATE_TYPE := "HV000";
FDW_SPECIFIC_CONDITION_COLUMN_NAME_NOT_FOUND:
    constant SQLSTATE_TYPE := "HV005";
FDW_SPECIFIC_CONDITION_DYNAMIC_PARAMETER_VALUE_NEEDED:
    constant SQLSTATE_TYPE := "HV002";
FDW_SPECIFIC_CONDITION_FUNCTION_SEQUENCE_ERROR:
    constant SQLSTATE_TYPE := "HV010";
FDW_SPECIFIC_CONDITION_INCONSISTENT_DESCRIPTOR_INFORMATION:
    constant SQLSTATE_TYPE := "HV021";
FDW_SPECIFIC_CONDITION_INVALID_ATTRIBUTE_VALUE:
    constant SQLSTATE_TYPE := "HV024";
FDW_SPECIFIC_CONDITION_INVALID_COLUMN_NAME:
    constant SQLSTATE_TYPE := "HV007";
FDW_SPECIFIC_CONDITION_INVALID_COLUMN_NUMBER:
    constant SQLSTATE_TYPE := "HV008";
FDW_SPECIFIC_CONDITION_INVALID_DATA_TYPE:
    constant SQLSTATE_TYPE := "HV004";
FDW_SPECIFIC_CONDITION_INVALID_DATA_TYPE_DESCRIPTOR:

```

```

    constant SQLSTATE_TYPE := "HV006";
FDW_SPECIFIC_CONDITION_INVALID_DESCRIPTOR_FIELD_IDENTIFIER:
    constant SQLSTATE_TYPE := "HV091";
FDW_SPECIFIC_CONDITION_INVALID_HANDLE:
    constant SQLSTATE_TYPE := "HV00B";
FDW_SPECIFIC_CONDITION_INVALID_OPTION_INDEX:
    constant SQLSTATE_TYPE := "HV00C";
FDW_SPECIFIC_CONDITION_INVALID_OPTION_NAME:
    constant SQLSTATE_TYPE := "HV00D";
FDW_SPECIFIC_CONDITION_INVALID_STRING_FORMAT:
    constant SQLSTATE_TYPE := "HV00A";
FDW_SPECIFIC_CONDITION_INVALID_STRING_LENGTH_OR_BUFFER_LENGTH:
    constant SQLSTATE_TYPE := "HV090";
FDW_SPECIFIC_CONDITION_INVALID_USE_OF_NULL_POINTER:
    constant SQLSTATE_TYPE := "HV009";
FDW_SPECIFIC_CONDITION_LIMIT_ON_NUMBER_OF_HANDLES_EXCEEDED:
    constant SQLSTATE_TYPE := "HV014";
FDW_SPECIFIC_CONDITION_MEMORY_ALLOCATION_ERROR:
    constant SQLSTATE_TYPE := "HV001";
FDW_SPECIFIC_CONDITION_NO_SCHEMAS:
    constant SQLSTATE_TYPE := "HV00P";
FDW_SPECIFIC_CONDITION_OPTION_NAME_NOT_FOUND:
    constant SQLSTATE_TYPE := "HV00J";
FDW_SPECIFIC_CONDITION_REPLY_HANDLE:
    constant SQLSTATE_TYPE := "HY00K";
FDW_SPECIFIC_CONDITION_SCHEMA_NOT_FOUND:
    constant SQLSTATE_TYPE := "HV00Q";
FDW_SPECIFIC_CONDITION_TABLE_NOT_FOUND:
    constant SQLSTATE_TYPE := "HV00R";
FDW_SPECIFIC_CONDITION_UNABLE_TO_CREATE_EXECUTION:
    constant SQLSTATE_TYPE := "HV00L";
FDW_SPECIFIC_CONDITION_UNABLE_TO_CREATE_REPLY:
    constant SQLSTATE_TYPE := "HV00M";
FDW_SPECIFIC_CONDITION_UNABLE_TO_ESTABLISH_CONNECTION:
    constant SQLSTATE_TYPE := "HV00N";
INVALID_FOREIGN_SERVER_SPECIFICATION_NO_SUBCLASS:
    constant SQLSTATE_TYPE := "0X000";
PASSTHROUGH_SPECIFIC_CONDITION_NO_SUBCLASS:
    constant SQLSTATE_TYPE := "0Y000";
PASSTHROUGH_SPECIFIC_CONDITION_INVALID_CURSOR_OPTION:
    constant SQLSTATE_TYPE := "0Y001";
PASSTHROUGH_SPECIFIC_CONDITION_INVALID_CURSOR_ALLOCATION:
    constant SQLSTATE_TYPE := "0Y002";

```

Access Rules

No additional Access Rules.

General Rules

No additional General Rules.

Conformance Rules

No additional Conformance Rules.

14.4 <SQL procedure statement>

This Subclause modifies Subclause 13.5, “<SQL procedure statement>”, in ISO/IEC 9075-2.

Function

Define all of the SQL-statements that are <SQL procedure statement>s.

Format

```
<SQL schema definition statement> ::=  
!! All alternatives from ISO/IEC 9075-2  
| <foreign table definition>  
| <foreign server definition>  
| <foreign-data wrapper definition>  
| <user mapping definition>  
| <routine mapping definition>  
  
<SQL schema manipulation statement> ::=  
!! All alternatives from ISO/IEC 9075-2  
| <alter foreign table statement>  
| <drop foreign table statement>  
| <alter foreign server statement>  
| <drop foreign server statement>  
| <alter foreign-data wrapper statement>  
| <drop foreign-data wrapper statement>  
| <alter user mapping statement>  
| <drop user mapping statement>  
| <alter routine mapping statement>  
| <drop routine mapping statement>  
  
<SQL session statement> ::=  
!! All alternatives from ISO/IEC 9075-2  
| <set passthrough statement>
```

Syntax Rules

No additional Syntax Rules.

Access Rules

No additional Access Rules.

General Rules

No additional General Rules.

Conformance Rules

No additional Conformance Rules.

14.5 Data type correspondences

This Subclause modifies Subclause 13.6, “Data type correspondences”, in ISO/IEC 9075-2.

Function

Specify the data type correspondences for SQL data types and host language types.

Tables

Table 5, “Data type correspondences for Ada”, modifies Table 16, “Data type correspondences for Ada”, in ISO/IEC 9075-2.

Table 5 — Data type correspondences for Ada

SQL Data Type	Ada Data Type
All alternatives from ISO/IEC 9075-2	
DATALINK	SQL_STANDARD.CHAR, with P'LENGTH of LD^1
¹ The length LD of the Ada character type corresponding with SQL data type DATALINK is the smallest integer not less than the quotient of the division N/B , where N is the maximum datalink length and B is the implementation-defined number of octets contained in a character of the host language. (The term “maximum datalink length” is defined in Subclause 4.8, “Datalinks”.)	

Table 6, “Data type correspondences for C”, modifies Table 17, “Data type correspondences for C”, in ISO/IEC 9075-2.

Table 6 — Data type correspondences for C

SQL Data Type	C Data Type
All alternatives from ISO/IEC 9075-2	
DATALINK	char, with length LD^5
⁵ The length LD of the C character type corresponding with SQL data type DATALINK is the smallest integer not less than the quotient of the division N/B , where N is the maximum datalink length and B is the implementation-defined number of octets contained in a character of the host language. (The term “maximum datalink length” is defined in Subclause 4.8, “Datalinks”.)	

Table 7, “Data type correspondences for COBOL”, modifies Table 18, “Data type correspondences for COBOL”, in ISO/IEC 9075-2.

Table 7 — Data type correspondences for COBOL

SQL Data Type	COBOL Data Type
<i>All alternatives from ISO/IEC 9075-2</i>	
DATALINK	alphanumeric, with length LD^4
⁴ The length LD of the COBOL character type corresponding with SQL data type DATALINK is the smallest integer not less than the quotient of the division N/B , where N is the maximum datalink length and B is the implementation-defined number of octets contained in a character of the host language. (The term “maximum datalink length” is defined in Subclause 4.8, “Datalinks”.)	

Table 8, “Data type correspondences for Fortran”, modifies Table 19, “Data type correspondences for Fortran”, in ISO/IEC 9075-2.

Table 8 — Data type correspondences for Fortran

SQL Data Type	Fortran Data Type
<i>All alternatives from ISO/IEC 9075-2</i>	
DATALINK	CHARACTER with length LD^4
⁴ The length LD of the Fortran character type corresponding with SQL data type DATALINK is the smallest integer not less than the quotient of the division N/B , where N is the maximum datalink length and B is the implementation-defined number of octets contained in a character of the host language. (The term “maximum datalink length” is defined in Subclause 4.8, “Datalinks”.)	

Table 9, “Data type correspondences for M”, modifies Table 20, “Data type correspondences for M”, in ISO/IEC 9075-2.

Table 9 — Data type correspondences for M

SQL Data Type	MUMPS Data Type
<i>All alternatives from ISO/IEC 9075-2</i>	
DATALINK	character

Table 10, “Data type correspondences for Pascal”, modifies Table 21, “Data type correspondences for Pascal”, in ISO/IEC 9075-2.

Table 10 — Data type correspondences for Pascal

SQL Data Type	Pascal Data Type
<i>All alternatives from ISO/IEC 9075-2</i>	
DATALINK	PACKED ARRAY[1.. LD^2] OF CHAR
² The length LD of the Pascal character type corresponding with SQL data type DATALINK is the smallest integer not less than the quotient of the division N/B , where N is the maximum datalink length and B is the implementation-defined number of octets contained in a character of the host language. (The term “maximum datalink length” is defined in Subclause 4.8, “Datalinks”.)	

Table 11, “Data type correspondences for PL/I”, modifies Table 22, “Data type correspondences for PL/I”, in ISO/IEC 9075-2.

Table 11 — Data type correspondences for PL/I

SQL Data Type	PL/I Data Type
<i>All alternatives from ISO/IEC 9075-2</i>	
DATALINK	CHARACTER VARYING(LD^2)
² The length LD of the PL/I character type corresponding with SQL data type DATALINK is the smallest integer not less than the quotient of the division N/B , where N is the maximum datalink length and B is the implementation-defined number of octets contained in a character of the host language. (The term “maximum datalink length” is defined in Subclause 4.8, “Datalinks”.)	

Conformance Rules

No additional Conformance Rules.

(Blank page)

15 Data manipulation

This Clause modifies Clause 14, “Data manipulation”, in ISO/IEC 9075-2.

15.1 Effect of deleting rows from base tables

This Subclause modifies Subclause 14.16, “Effect of deleting rows from base tables”, in ISO/IEC 9075-2.

Function

Specify the effect of deleting rows from one or more base tables.

Syntax Rules

No additional Syntax Rules.

Access Rules

No additional Access Rules.

General Rules

- 1) Insert after For each row *R* that is marked for deletion from *T*, for each site *DLC* whose value is a constituent of the value of *R* such that the declared type of *DLC* is DATALINK or some distinct type whose source data type is DATALINK, and such that the data type descriptor of the declared type of *DLC* is or includes a datalink data type descriptor with link control option FILE LINK CONTROL, let *DLCV* be the value of *DLC*.

NOTE 40 — “constituent” is defined in Subclause 4.9, “Columns, fields, and attributes”.

- 2) Insert after If *DLCV* is not the null value, then let *EF* be the external file referenced by *DLCV*.

Case:

- a) If *EF* is not linked and the integrity control option included in the descriptor of *DLC* specifies INTEGRITY ALL, then an exception condition is raised: *datalink exception — external file not linked*.
- b) If *EF* is linked, then *EF* is unlinked.

NOTE 41 — The effect of unlinking depends on the unlink control option, RESTORE or DELETE, included in the column descriptor of *C*, as specified in Subclause 4.8, “Datalinks”.

Conformance Rules

No additional Conformance Rules.

15.2 Effect of inserting tables into base tables

This Subclause modifies Subclause 14.19, “Effect of inserting tables into base tables”, in ISO/IEC 9075-2.

Function

Specify the effect of inserting each of one or more given tables into its associated base table.

Syntax Rules

No additional Syntax Rules.

Access Rules

No additional Access Rules.

General Rules

- 1) Insert after GR 5)b) For each row *R* inserted into *T*, for each site *DLC* whose value is a constituent of the value of *R* such that the declared type of *DLC* is DATALINK or some distinct type whose source type is DATALINK, and such that the data type descriptor of the declared type of *DLC* is or includes a datalink data type descriptor with link control options FILE LINK CONTROL and either INTEGRITY ALL or INTEGRITY SELECTIVE, let *DLCV* be the value of *DLC*.

NOTE 42 — “constituent” is defined in Subclause 4.9, “Columns, fields, and attributes”.

- a) If *DLCV* is not the null value, then

Case:

- i) If *DLCV* does not reference a file, then an exception condition is raised: *datalink exception — referenced file does not exist*.
- ii) Otherwise, let *EF* be the external file referenced by *DLCV*.

- b) Case:

- i) If the Construction Indication of *DLCV* is not the null value, then an exception condition is raised: *datalink exception — invalid datalink construction*.
- ii) If *EF* is linked, then an exception condition is raised: *datalink exception — external file already linked*.
- iii) If INTEGRITY ALL is specified, then *EF* is linked according to the <datalink file control option> READ PERMISSION and WRITE PERMISSION of *DLC*.
- iv) If INTEGRITY SELECTIVE is specified, then *EF* may be linked in an implementation-defined manner according to the <datalink file control option> READ PERMISSION and WRITE PERMISSION of *DLC*.

- c) Case:

15.2 Effect of inserting tables into base tables

- i) If the read permission option included in the descriptor of *DLC* is DB, then the SQL-Mediated Read Access Indication of *DLCV* is set to True.
- ii) Otherwise, the SQL-Mediated Read Access Indication of *DLCV* is set to False.
- d) Case:
 - i) If the write permission option included in the descriptor of *DLC* is either ADMIN REQUIRING TOKEN FOR UPDATE or ADMIN NOT REQUIRING TOKEN FOR UPDATE, then the SQL-Mediated Write Access Indication of *DLCV* is set to True.
 - ii) Otherwise, the SQL-Mediated Write Access Indication of *DLCV* is set to False.
- e) The Write Token of *DLCV* is set to the null value.
- f) The Construction Indication of *DLCV* is set to the null value.

Conformance Rules

No additional Conformance Rules.

15.3 Effect of replacing rows in base tables

This Subclause modifies Subclause 14.22, “Effect of replacing rows in base tables”, in ISO/IEC 9075-2.

Function

Specify the effect of replacing some of the rows in one or more base tables.

Syntax Rules

No additional Syntax Rules.

Access Rules

No additional Access Rules.

General Rules

- 1) Insert after GR 8 For each replaced row *R*, for each site *DLC* whose value is a constituent of the value of *R* such that the declared type of *DLC* is DATALINK or some distinct type source type is DATALINK, and such that the data type descriptor of the declared type of *DLC* is or includes a datalink data type descriptor with link control options FILE LINK CONTROL and either INTEGRITY ALL or INTEGRITY SELECTIVE, let *DLCV1* be the value of *DLC* and let *DLCV2* be the value of the site in the new transition variable that corresponds to *DLC*.

NOTE 43 — “constituent” is defined in Subclause 4.9, “Columns, fields, and attributes”.

- a) If *DLCV1* is not the null value, then let *EF1* be the external file referenced by *DLCV1*.

Case:

- i) If *EF1* is not linked and the integrity control option included in the descriptor of *DLC* specifies INTEGRITY ALL, then an exception condition is raised: *datalink exception — external file not linked*.
- ii) If *EF1* is linked, *EF1* is unlinked.

NOTE 44 — The effect of unlinking depends on the unlink control option, RESTORE or DELETE, included in the column descriptor of *C*, as specified in Subclause 4.8, “Datalinks”.

- b) If *DLCV2* is not the null value, then

i) Case:

- 1) If *DLCV2* does not reference a file, then an exception condition is raised: *datalink exception — referenced file does not exist*.
- 2) Otherwise, let *EF2* be the external file referenced by *DLCV2*.

ii) Case:

15.3 Effect of replacing rows in base tables

- 1) If *EF2* is linked, then an exception condition is raised: *datalink exception — external file already linked*.
 - 2) If the Construction Indication of *DLCV2* is either *NEWCOPY* or *PREVIOUSCOPY*, then:
 - A) If the write permission option included in the descriptor of *DLC* is *ADMIN REQUIRING TOKEN FOR UPDATE*, then
Case:
 - I) If the Write Token of *DLCV2* is the null value, then an exception condition is raised: *datalink exception — invalid write token*.
 - II) If the Write Token of *DLCV2* is not valid according to implementation-defined rules, then an exception condition is raised: *datalink exception — invalid write token*.
 - B) If the write permission option included in the descriptor of *DLC* is *BLOCKED*, then an exception condition is raised: *datalink exception — invalid write permission for update*.
 - C) If the File Reference of *DLCV1* and the File Reference of *DLCV2* are not identical, then an exception condition is raised: *datalink exception — referenced file not valid*.
 - D) *EF2* is linked according to the read permission option and write permission option included in the descriptor of *DLC*.
 - 3) If *INTEGRITY ALL* is specified, then *EF2* is linked according to the <datalink file control option> of *READ PERMISSION* and *WRITE PERMISSION* of *DLC*.
 - 4) If *INTEGRITY SELECTIVE* is specified, then *EF2* may be linked in an implementation-defined manner according to the <datalink file control option> of *READ PERMISSION* and *WRITE PERMISSION* of *DLC*.
- iii) Case:
- 1) If the read permission option included in the descriptor of *DLC* is *DB*, then the SQL-Mediated Read Access Indication of *DLCV2* is set to *True*.
 - 2) Otherwise, the SQL-Mediated Read Access Indication of *DLCV2* is set to *False*.
- iv) Case:
- 1) If the write permission option included in the descriptor of *DLC* is either *ADMIN REQUIRING TOKEN FOR UPDATE* or *ADMIN NOT REQUIRING TOKEN FOR UPDATE*, then the SQL-Mediated Write Access Indication of *DLCV2* is set to *True*.
 - 2) Otherwise, the SQL-Mediated Write Access Indication of *DLCV2* is set to *False*.
- v) The Write Token of *DLCV2* is set to the null value.
- vi) The Construction Indication of *DLCV2* is set to the null value.

Conformance Rules

No additional Conformance Rules.

16 Session management

This Clause modifies Clause 18, “Session management”, in ISO/IEC 9075-2.

16.1 <set passthrough statement>

Function

Set the pass-through flag to *True* or *False* for the current SQL-session context.

Format

```
<set passthrough statement> ::= SET PASSTHROUGH <passthrough specification>  
  
<passthrough specification> ::=  
<value specification>  
| OFF
```

Syntax Rules

- 1) The declared type of the <value specification> shall be a character string type.

Access Rules

None.

General Rules

- 1) If there is a pass-through foreign server name included in the current SQL-session context, then let *FSN* be that pass-through foreign server name, let *WN* be the name of the foreign-data wrapper included in the foreign server descriptor of the foreign server identified by *FSN*, let *WR* be the foreign-data wrapper identified by *WN*, and let *WRLN* be the name of the library identified in the foreign-data wrapper descriptor of *WR*.
- 2) For each execution handle *EXH_i* that is part of an {<SQL statement name> : ExecutionHandle} pair that is present in the current SQL-session context, the `FreeExecutionHandle()` routine in the library identified by *WRLN* is invoked with *EXH_i* as the argument.
- 3) All {<SQL statement name> : ExecutionHandle} pairs present in the current SQL-session context are removed from the current SQL-session context.
- 4) Case:

16.1 <set passthrough statement>

- a) If <value specification> is specified, then:
 - i) Let S be <value specification> and let V be the character string that is the value of
`TRIM (BOTH ' ' FROM S)`
 - ii) If V does not conform to the Format and Syntax Rules of a <foreign server name>, then an exception condition is raised: *invalid foreign server specification*.
 - iii) If a foreign server descriptor that includes V as the foreign server name exists, then let FS be that foreign server. Otherwise, an exception condition is raised: *invalid foreign server specification*.
 - iv) If the current privileges do not include USAGE privilege on FS , then an exception condition is raised: *invalid foreign server specification*.
 - v) The pass-through flag of the current SQL-session context is set to True.
 - vi) The pass-through foreign server name included in the current SQL-session context is set to the foreign server name of FS .
- b) Otherwise:
 - i) The pass-through flag of the current SQL-session context is set to False.
 - ii) The pass-through foreign server name included in the current SQL-session context is deleted.

Conformance Rules

- 1) Without Feature M004, “Foreign data support”, conforming SQL language shall not contain a <set passthrough statement>.

17 Dynamic SQL

This Clause modifies Clause 19, “Dynamic SQL”, in ISO/IEC 9075-2.

17.1 Description of SQL descriptor areas

This Subclause modifies Subclause 19.1, “Description of SQL descriptor areas”, in ISO/IEC 9075-2.

Function

Specify the identifiers, data types, and codes used in SQL item descriptor areas.

Syntax Rules

- 1) Insert before SR 6)q) TYPE indicates DATALINK.
- 2) Insert before SR 7)w) TYPE indicates DATALINK and *T* is specified by DATALINK.

Access Rules

No additional Access Rules.

General Rules

- 1) Replace GR 1) Table 12, “Codes used for SQL data types in Dynamic SQL”, specifies the codes associated with the SQL data types.

Table 12, “Codes used for SQL data types in Dynamic SQL”, modifies Table 25, “Codes used for SQL data types in Dynamic SQL”, in ISO/IEC 9075-2.

Table 12 — Codes used for SQL data types in Dynamic SQL

Data Type	Code
<i>All alternatives from ISO/IEC 9075-2</i>	<i>All alternatives from ISO/IEC 9075-2</i>
DATALINK	70

Conformance Rules

No additional Conformance Rules.

17.2 <prepare statement>

This Subclause modifies Subclause 19.6, “<prepare statement>”, in ISO/IEC 9075-2.

Function

Prepare a statement for execution.

Format

No additional Format items.

Syntax Rules

No additional Syntax Rules.

Access Rules

No additional Access Rules.

General Rules

- 1) Insert before GR 1 If the pass-through flag of the current SQL-session context is *True* and if <SQL statement variable> conforms to the Format and Syntax Rules of a <preparable statement> other than <set passthrough statement>, then:
 - a) Let *FSN* be the pass-through foreign server name included in the current SQL-session context. Let *WN* be the name of the foreign-data wrapper included in the foreign server descriptor of the foreign server identified by *FSN*. Let *WR* be the foreign-data wrapper identified by *WN*. Let *WRLN* be the name of the library identified in the foreign-data wrapper descriptor of *WR*.
 - b) Case:
 - i) If the current SQL-session context includes a {foreign-data wrapper name : Wrapper-EnvHandle} pair whose foreign-data wrapper name is equivalent to *WN*, then let *WEH* be the WrapperEnvHandle associated with *WN*.
 - ii) Otherwise:
 - 1) Let *WH* be the WrapperHandle allocated for the foreign-data wrapper identified by *WN*. The resource identified by *WH* is referred to as an *allocated foreign-data wrapper description*.
 - 2) Let *WEH* be the WrapperEnvHandle returned by the invocation of `AllocWrapperEnv ()` in the library identified by *WRLN*, with *WH* as the argument.
 - 3) The { *WN* : *WEH* } pair is included in the current SQL-session context.
 - 4) *WH* is deallocated and all its resources are freed.
 - c) Case:

17.2 <prepare statement>

- i) If the current SQL-session context includes a {foreign server name : FSConnection-Handle} pair whose foreign server name is equivalent to *FSN*, then let *FSCH* be the FSConnectionHandle associated with *FSN*.
- ii) Otherwise:
 - 1) Let *SH* be the ServerHandle allocated for the foreign server identified by *FSN*. The resource identified by *SH* is referred to as an *allocated foreign server description*.
 - 2) If there is a user mapping identified by the current authorization identifier, then let *UH* be the UserHandle allocated for that user mapping; otherwise, let *UH* be the UserHandle allocated for the user mapping identified by PUBLIC. The resource identified by *UH* is referred to as an *allocated user mapping description*.
 - 3) Let *FSCH* be the FSConnectionHandle returned by the invocation of ConnectServer () in the library identified by *WRLN* with *WEH*, *SH*, and *UH* as the arguments.
 - 4) The {*FSN* : *FSCH*} pair is included in the current SQL-session context.
 - 5) *SH* is deallocated and all its resources are freed.
 - 6) *UH* is deallocated and all its resources are freed.
- d) Let *STV* be the contents of <SQL statement variable>. Let *STVL* be the length of *STV*. Let *EXH* be the ExecutionHandle returned by the invocation of TransmitRequest () in the library identified by *WRLN* with *FSCH*, *STV*, and *STVL* as arguments.
- e) If the current SQL-session context includes an {SQL statement name : ExecutionHandle} pair whose SQL statement name is equivalent to <SQL statement name>, then let *OEXH* be the ExecutionHandle associated with <SQL statement name>.
 - i) The FreeExecutionHandle () routine in the library identified by *WRLN* is invoked with *OEXH* as the argument.
 - ii) The {SQL statement name : ExecutionHandle} pair whose SQL statement name is equivalent to <SQL statement name> is removed from the current SQL-session context.
- f) The {<SQL statement name> : *EXH*} pair is included in the current SQL-session context.
- g) No further General Rules of this Subclause are applied.

Conformance Rules

No additional Conformance Rules.

17.3 <deallocate prepared statement>

This Subclause modifies Subclause 19.8, “<deallocate prepared statement>”, in ISO/IEC 9075-2.

Function

Deallocate SQL-statements that have been prepared with a <prepare statement>.

Format

No additional Format items.

Syntax Rules

No additional Syntax Rules.

Access Rules

No additional Access Rules.

General Rules

- 1) Insert before GR 1 If the pass-through flag of the current SQL-session context is *True*, and the current SQL-session context includes an {SQL statement name : ExecutionHandle} pair whose SQL statement name is equivalent to <SQL statement name>, then:
 - a) Let *FSN* be the pass-through foreign server name included in the current SQL-session context. Let *WN* be the name of the foreign-data wrapper included in the foreign server descriptor of the foreign server identified by *FSN*. Let *WR* be the foreign-data wrapper identified by *WN*. Let *WRLN* be the name of the library identified in the foreign-data wrapper descriptor of *WR*. Let *EXH* be the ExecutionHandle associated with <SQL statement name>.
 - b) The `FreeExecutionHandle()` routine in the library identified by *WRLN* is invoked with *EXH* as the argument.
 - c) The {SQL statement name : ExecutionHandle} pair whose SQL statement name is equivalent to <SQL statement name> is removed from the current SQL-session context.
 - d) No further General Rules of this Subclause are applied.

Conformance Rules

No additional Conformance Rules.

17.4 <describe statement>

This Subclause modifies Subclause 19.9, “<describe statement>”, in ISO/IEC 9075-2.

Function

Obtain information about the <select list> columns or <dynamic parameter specification>s contained in a prepared statement or about the columns of the result set associated with a cursor.

Format

No additional Format items.

Syntax Rules

No additional Syntax Rules.

Access Rules

No additional Access Rules.

General Rules

- 1) Insert before GR 1) If the pass-through flag of the current SQL-session context is *True*, and the current SQL-session context includes an {SQL statement name : ExecutionHandle} pair whose SQL statement name is equivalent to <SQL statement name>, then:
 - a) Let *EXH* be the ExecutionHandle associated with <SQL statement name>. Let *WPD* and *WRD* be the wrapper parameter descriptor and wrapper row descriptor, respectively, associated with the *WPDHandle* and *WRDHandle*, respectively, that would be returned by the invocation of *GetWPDHandle()* and *GetWRDHandle()* with *EXH* as the ExecutionHandle parameter.
 - b) An SQL system descriptor area shall have been allocated and not yet deallocated whose name is the value of the <descriptor name>'s <simple value specification> and whose scope is that specified by the <scope option>. Otherwise, an exception condition is raised: *invalid SQL descriptor name*.
 - c) Let *DA* be the descriptor area identified by the <descriptor name>. Let *N* be the <occurrences> specified when *DA* was allocated.
 - d) *DA* is set as follows:
 - i) If the statement being executed is a <describe output statement>, then:
 - 1) Let *TD* be the value of the COUNT field in *WRD*.
 - 2) If *TD* is greater than *N*, then a completion condition is raised: *warning — insufficient item descriptor areas*.
 - 3) All header fields are set to the values of the header fields of *WRD* with the same name.

- 4) If TD is 0 (zero) or TD is greater than N , then no item descriptor areas are set. Otherwise, the first TD item descriptor areas are set with values from the corresponding item descriptor areas and, optionally, subordinate descriptors from WRD .
- ii) If the statement being executed is a <describe input statement>, then:
- 1) Let TD be the value of the COUNT field in WPD .
 - 2) If TD is greater than N , then a completion condition is raised: *warning — insufficient item descriptor areas*.
 - 3) All header fields are set to the values of the header fields of WPD with the same name.
 - 4) If TD is 0 (zero) or TD is greater than N , then no item descriptor areas are set. Otherwise, the first TD item descriptor areas are set with values from the corresponding item descriptor areas and, optionally, subordinate descriptors from WPD .
- e) No further General Rules of this Subclause are applied.
- 2) Insert after GR 7)d)x) If TYPE indicates DATALINK, then LENGTH and OCTET_LENGTH are set to the maximum datalink length.

NOTE 45 — The term “maximum datalink length” is defined in Subclause 4.8, “Datalinks”.

Conformance Rules

No additional Conformance Rules.

17.5 <input using clause>

This Subclause modifies Subclause 19.10, “<input using clause>”, in ISO/IEC 9075-2.

Function

Supply input values for an <SQL dynamic statement>.

Format

No additional Format items.

Syntax Rules

No additional Syntax Rules.

Access Rules

No additional Access Rules.

General Rules

- 1) Insert after GR 1) If the pass-through flag of the current SQL-session context is *True*, then:
 - a) Let *HL1* be the standard host language in which the SQL-server is written and let *HL2* be the standard host language in which the foreign-data wrapper is written.
 - b) Case:
 - i) If an <input using clause> is used in a <dynamic open statement>, then let *SN* be the <statement name> of the associated <dynamic declare cursor>.
 - ii) Otherwise, let *SN* be the <SQL statement name> of the <execute statement>.
 - c) Let *EXH* be the ExecutionHandle associated with *SN*. Let *WPD* and *SPD* be the wrapper parameter descriptor and server parameter descriptor, respectively, associated with the WPDHandle and SPDHandle, respectively, that would be returned by the invocation of `GetWPDHandle()` and `GetSPDHandle()` with *EXH* as the ExecutionHandle parameter.
 - d) Let *D* be the value of COUNT in *WPD*.
 - e) If <using arguments> is specified and the number of <using argument>s is not *D*, then an exception condition is raised: *dynamic SQL error — using clause does not match dynamic parameter specifications*.
 - f) If <using input descriptor> is specified, then:
 - i) Let *DA* be the descriptor area identified by <descriptor name>.
 - ii) Let *N* be the value of COUNT in *DA*.

- iii) If N is greater than the value of <occurrences> specified when the SQL descriptor area identified by <descriptor name> was allocated or is less than zero, then an exception condition is raised: *dynamic SQL error — invalid descriptor count.*
- iv) If the first N item descriptor areas in DA are not valid as specified in Subclause 17.1, “Description of SQL descriptor areas”, then an exception condition is raised: *dynamic SQL error — using clause does not match dynamic parameter specifications.*
- v) In the first N item descriptor areas in DA :
 - 1) If the number of item descriptor areas in which the value of LEVEL is 0 (zero) is not D , then an exception condition is raised: *dynamic SQL error — using clause does not match dynamic parameter specifications.*
 - 2) If the value of INDICATOR is not negative, TYPE does not indicate ROW, and the item descriptor area is not subordinate to an item descriptor area whose INDICATOR value is negative or whose TYPE field indicates ARRAY, ARRAY LOCATOR, MULTISSET, or MULTISSET LOCATOR, and if the value of DATA is not a valid value of the data type represented by the item descriptor area, then an exception condition is raised: *dynamic SQL error — using clause does not match dynamic parameter specifications.*
- g) For $1 \text{ (one)} \leq i \leq D$:
 - i) Let TDT be the effective declared type of the i -th input <dynamic parameter specification> defined by the type representation of the corresponding item descriptor area and its subordinate descriptor areas in WPD .
 - ii) Case:
 - 1) If <using input descriptor> is specified, then:
 - A) Let IDA be the i -th item descriptor area in DA whose LEVEL value is 0 (zero).
 - B) Let SDT be the effective declared type represented by IDA .
 - C) Let SV be the associated value of IDA , which is defined to be
 - Case:
 - I) If the value of INDICATOR is negative, then SV is the null value.
 - II) Otherwise,
 - Case:
 - 1) If TYPE indicates ROW, then SV is a row whose type is SDT and whose field values are the associated values of the immediately subordinate descriptor areas of IDA .
 - 2) Otherwise, SV is the value of DATA with data type SDT .
 - 2) If <using arguments> is specified, then let SDT and SV be the declared type and value, respectively, of the i -th <using argument>.
 - iii) Case:
 - 1) If SDT is a locator type, then

Case:

- A) If *SV* is not the null value, then let the value TV_i of the *i*-th dynamic parameter be the value of *SV*.
 - B) Otherwise, let the value TV_i of the *i*-th dynamic parameter be the null value.
- 2) If *SDT* and *TDT* are predefined data types, then

Case:

- A) If the <cast specification>

CAST (*SV* AS *TDT*)

does not conform to the Syntax Rules of Subclause 6.12, “<cast specification>”, in ISO/IEC 9075-2, and there is an implementation-defined conversion from type *SDT* to type *TDT*, then that implementation-defined conversion is effectively performed, converting *SV* to type *TDT*, and the result is the value TV_i of the *i*-th input dynamic parameter.

- B) Otherwise:

- I) If the <cast specification>

CAST (*SV* AS *TDT*)

does not conform to the Syntax Rules of Subclause 6.12, “<cast specification>”, in ISO/IEC 9075-2, then an exception condition is raised: *dynamic SQL error — restricted data type attribute violation*.

- II) If the <cast specification>

CAST (*SV* AS *TDT*)

does not conform to the General Rules of Subclause 6.12, “<cast specification>”, in ISO/IEC 9075-2, then an exception condition is raised in accordance with the General Rules of Subclause 6.12, “<cast specification>”, in ISO/IEC 9075-2.

- III) The <cast specification>

CAST (*SV* AS *TDT*)

is effectively performed and the result is the value TV_i of the *i*-th input dynamic parameter.

- iv) Case:

- 1) If <using input descriptor> is specified, then all fields, except DATA and DATA_POINTER, in the *i*-th item descriptor area of *SPD*, that can be set according to Table 33, “Ability to set foreign-data wrapper descriptor fields”, are set with values from the corresponding fields of the item descriptor area and, optionally, subordinate descriptors of *DA*.
- 2) If <using arguments> is specified, then all fields, except DATA and DATA_POINTER, in the *i*-th item descriptor area of *SPD*, that can be set according to Table 33, “Ability to set foreign-data wrapper descriptor fields”, are set to implementation-dependent values.

- v) Case:

- 1) If *HL1* and *HL2* are both pointer-supporting languages, then the `DATA_POINTER` field in the *i*-th item descriptor area of *SPD* is set to the address of the buffer that contains the value TV_i .
 - 2) Otherwise, the `DATA` field in the *i*-th item descriptor area of *SPD* is set to TV_i .
- h) All header fields in *SPD*, that can be set according to Table 33, “Ability to set foreign-data wrapper descriptor fields”, are set to the values of the header fields of *WPD* with equivalent names.
- i) No further General Rules of this Subclause are applied.

Conformance Rules

No additional Conformance Rules.

17.6 <output using clause>

This Subclause modifies Subclause 19.11, “<output using clause>”, in ISO/IEC 9075-2.

Function

Supply output variables for an <SQL dynamic statement>.

Format

No additional Format items.

Syntax Rules

No additional Syntax Rules.

Access Rules

No additional Access Rules.

General Rules

- 1) Insert after GR 1) If the pass-through flag of the current SQL-session context is *True*, then:
 - a) Let *HL1* be the standard host language in which the SQL-server is written and let *HL2* be the standard host language in which the foreign-data wrapper is written.
 - b) Case:
 - i) If an <output using clause> is used in a <dynamic fetch statement>, then let *SN* be the <statement name> of the associated <dynamic declare cursor>.
 - ii) Otherwise, let *SN* be the <SQL statement name> of the <execute statement>.
 - c) Let *EXH* be the ExecutionHandle associated with *SN*. Let *WRD* and *SRD* be the wrapper row descriptor and server row descriptor, respectively, associated with the WRDHandle and SRDHandle, respectively, that would be returned by the invocation of `GetWRDHandle()` and `GetSRDHandle()` with *EXH* as the ExecutionHandle parameter.
 - d) Let *D* be the value of COUNT in *WRD*.
 - e) If <into arguments> is specified and the number of <into argument>s is not *D*, then an exception condition is raised: *dynamic SQL error — using clause does not match target specifications*.
 - f) If <into descriptor> is specified, then:
 - i) Let *DA* be the descriptor area identified by <descriptor name>.
 - ii) Let *N* be the value of COUNT in *DA*.

- iii) If N is greater than the value of <occurrences> specified when the SQL descriptor area identified by <descriptor name> was allocated or is less than zero, then an exception condition is raised: *dynamic SQL error — invalid descriptor count*.
 - iv) If the first N item descriptor areas in DA are not valid as specified in Subclause 17.1, “Description of SQL descriptor areas”, then an exception condition is raised: *dynamic SQL error — using clause does not match target specifications*.
 - v) In the first N item descriptor areas in DA , if the number of item descriptor areas in which the value of LEVEL is 0 (zero) is not D , then an exception condition is raised: *dynamic SQL error — using clause does not match target specifications*.
- g) For $1 \text{ (one)} \leq i \leq D$:
- i) Let SDT be the effective declared type of i -th descriptor area whose LEVEL value is 0 (zero) and its subordinate descriptor areas in WRD .

Case:

 - 1) If $HL1$ and $HL2$ are both pointer-supporting languages, then let SV be the value of the buffer addressed by the DATA_POINTER field in the corresponding item descriptor area of SRD , with data type SDT .
 - 2) Otherwise, let SV be the value of the DATA field in the corresponding item descriptor area of SRD , with data type SDT .
 - ii) Case:
 - 1) If <into descriptor> is specified, then:
 - A) Let IDA be the i -th item descriptor area in DA whose LEVEL value is 0 (zero).
 - B) Let TDT be the declared type represented by IDA .
 - 2) If <into arguments> is specified, then let TDT be the data type of the i -th <into argument>.
 - iii) If the <output using clause> is used in a <dynamic fetch statement>, then let $LTDT$ be the data type on the most recently executed <dynamic fetch statement>, if any, for the cursor CR . It is implementation-defined whether or not an exception condition is raised: *dynamic SQL error — restricted data type attribute violation* if any of the following are true:
 - 1) $LTDT$ and TDT both identify a binary large object type and only one of $LTDT$ and TDT is a binary large object locator.
 - 2) $LTDT$ and TDT both identify a character large object type and only one of $LTDT$ and TDT is a character large object locator.
 - 3) $LTDT$ and TDT both identify an array type and only one of $LTDT$ and TDT is an array locator.
 - 4) $LTDT$ and TDT both identify a multiset type and only one of $LTDT$ and TDT is a multiset locator.
 - 5) $LTDT$ and TDT both identify a user-defined type and only one of $LTDT$ and TDT is a user-defined type locator.
 - iv) Case:

- 1) If *TDT* is a locator type, then

Case:

- A) If *SV* is not the null value, then a locator *L* that uniquely identifies *SV* is generated and is the value TV_i of the *i*-th <target specification>.
- B) Otherwise, the value TV_i of the *i*-th <target specification> is the null value.

- 2) If *SDT* and *TDT* are predefined data types, then

Case:

- A) If the <cast specification>

CAST (*SV* AS *TDT*)

does not conform to the Syntax Rules of Subclause 6.12, “<cast specification>”, in ISO/IEC 9075-2, and there is an implementation-defined conversion from type *SDT* to type *TDT*, then that implementation-defined conversion is effectively performed, converting *SV* to type *TDT*, and the result is the value TV_i of the *i*-th <target specification>.

- B) Otherwise:

- I) If the <cast specification>

CAST (*SV* AS *TDT*)

does not conform to the Syntax Rules of Subclause 6.12, “<cast specification>”, in ISO/IEC 9075-2, then an exception condition is raised: *dynamic SQL error — restricted data type attribute violation*.

- II) If the <cast specification>

CAST (*SV* AS *TDT*)

does not conform to the General Rules of Subclause 6.12, “<cast specification>”, in ISO/IEC 9075-2, then an exception condition is raised in accordance with the General Rules of Subclause 6.12, “<cast specification>”, in ISO/IEC 9075-2.

- III) The <cast specification>

CAST (*SV* AS *TDT*)

is effectively performed and the result is the value TV_i of the *i*-th <target specification>.

- v) Case:

- 1) If <into descriptor> is specified, then all fields in *IDA* are set with values from the corresponding fields of the item descriptor area and, optionally, subordinate descriptors of *SRD*.
- 2) If <into arguments> is specified, then the Rules in Subclause 9.1, “Retrieval assignment”, are applied to TV_i and the *i*-th <into argument> as *VALUE* and *TARGET*, respectively.

- h) No further General Rules of this Subclause are applied.

Conformance Rules

No additional Conformance Rules.

17.7 <execute statement>

This Subclause modifies Subclause 19.12, “<execute statement>”, in ISO/IEC 9075-2.

Function

Associate input SQL parameters and output targets with a prepared statement and execute the statement.

Format

No additional Format items.

Syntax Rules

No additional Syntax Rules.

Access Rules

No additional Access Rules.

General Rules

- 1) Insert before GR 1 If the pass-through flag of the current SQL-session context is *True*, and the current SQL-session context includes an {SQL statement name : ExecutionHandle} pair whose SQL statement name is equivalent to <SQL statement name>, then:
 - a) Let *FSN* be the pass-through foreign server name included in the current SQL-session context. Let *WN* be the name of the foreign-data wrapper included in the foreign server descriptor of the foreign server identified by *FSN*. Let *WR* be the foreign-data wrapper identified by *WN*. Let *WRLN* be the name of the library identified in the foreign-data wrapper descriptor of *WR*. Let *EXH* be the ExecutionHandle associated with <SQL statement name>.
 - b) If a <parameter using clause> is specified, then the General Rules specified in Subclause 17.5, “<input using clause>”, for a <parameter using clause> in an <execute statement> are applied.
 - c) The `Open ()` routine in the library identified by *WRLN* is invoked with *EXH* as argument.
 - d) If a <result using clause> is specified, then the General Rules specified in Subclause 17.6, “<output using clause>”, for a <result using clause> in an <execute statement> are applied.
 - e) No further General Rules of this Subclause are applied.

Conformance Rules

No additional Conformance Rules.

17.8 <dynamic declare cursor>

This Subclause modifies Subclause 19.14, “<dynamic declare cursor>”, in ISO/IEC 9075-2.

Function

Declare a cursor to be associated with a <statement name>, which may in turn be associated with a <cursor specification>.

Format

No additional Format items.

Syntax Rules

No additional Syntax Rules.

Access Rules

No additional Access Rules.

General Rules

- 1) Insert before GR 1) If the pass-through flag of the current SQL-session context is *True*, then:
 - a) If <cursor sensitivity> is specified, then an exception condition is raised: *pass-through specific condition — invalid cursor option*.
 - b) If <cursor scrollability> is specified, then an exception condition is raised: *pass-through specific condition — invalid cursor option*.
 - c) If <cursor holdability> is specified, then an exception condition is raised: *pass-through specific condition — invalid cursor option*.
 - d) If <cursor returnability> is specified, then an exception condition is raised: *pass-through specific condition — invalid cursor option*.
 - e) No further General Rules of this Subclause are applied.

Conformance Rules

No additional Conformance Rules.

17.9 <allocate cursor statement>

This Subclause modifies Subclause 19.15, “<allocate cursor statement>”, in ISO/IEC 9075-2.

Function

Define a cursor based on a prepared statement for a <cursor specification> or assign a cursor to the ordered set of result sets returned from an SQL-invoked procedure.

Format

No additional Format items.

Syntax Rules

No additional Syntax Rules.

Access Rules

No additional Access Rules.

General Rules

- 1) Insert before GR 1) If the pass-through flag of the current SQL-session context is *True*, then an exception condition is raised: *pass-through specific condition — invalid cursor allocation*.

Conformance Rules

No additional Conformance Rules.

17.10 <dynamic open statement>

This Subclause modifies Subclause 19.16, “<dynamic open statement>”, in ISO/IEC 9075-2.

Function

Associate input dynamic parameters with a <cursor specification> and open the cursor.

Format

No additional Format items.

Syntax Rules

No additional Syntax Rules.

Access Rules

No additional Access Rules.

General Rules

- 1) Insert before GR 1)a) If the pass-through flag of the current SQL-session context is *True*, and the current SQL-session context includes an {SQL statement name : ExecutionHandle} pair whose SQL statement name is equivalent to <SQL statement name>, then:
 - a) Let *FSN* be the name of the pass-through foreign server included in the current SQL-session context. Let *WN* be the name of the foreign-data wrapper included in the foreign server descriptor of the foreign server identified by *FSN*. Let *WR* be the foreign-data wrapper identified by *WN*. Let *WRLN* be the name of the library identified in the foreign-data wrapper descriptor of *WR*. Let *EXH* be the ExecutionHandle associated with <SQL statement name>.
 - b) If an <input using clause> is specified, then the General Rules specified in Subclause 17.5, “<input using clause>”, for <dynamic open statement> are applied.
 - c) The `Open ()` routine in the library identified by *WRLN* is invoked with *EXH* as argument.
 - d) No further General Rules of this Subclause are applied.

Conformance Rules

No additional Conformance Rules.

17.11 <dynamic fetch statement>

This Subclause modifies Subclause 19.17, “<dynamic fetch statement>”, in ISO/IEC 9075-2.

Function

Fetch a row for a cursor declared with a <dynamic declare cursor>.

Format

No additional Format items.

Syntax Rules

No additional Syntax Rules.

Access Rules

No additional Access Rules.

General Rules

- 1) Insert before GR If the pass-through flag of the current SQL-session context is *True*, and the current SQL-session context includes a {SQL statement name : ExecutionHandle} pair whose SQL statement name is equivalent to <SQL statement name>, then:
 - a) Let *FSN* be the pass-through foreign server name included in the current SQL-session context. Let *WN* be the name of the foreign-data wrapper included in the foreign server descriptor of the foreign server identified by *FSN*. Let *WR* be the foreign-data wrapper identified by *WN*. Let *WRLN* be the name of the library identified in the foreign-data wrapper descriptor of *WR*. Let *EXH* be the ExecutionHandle associated with <SQL statement name>.
 - b) The `Iterate()` routine in the library identified by *WRLN* is invoked with *EXH* as argument.
 - c) The General Rules of Subclause 17.6, “<output using clause>”, are applied to the <dynamic fetch statement> and the current row of *CR* as the retrieved row.
 - d) No further General Rules of this Subclause are applied.

Conformance Rules

No additional Conformance Rules.

17.12 <dynamic close statement>

This Subclause modifies Subclause 19.19, “<dynamic close statement>”, in ISO/IEC 9075-2.

Function

Close a cursor.

Format

No additional Format items.

Syntax Rules

No additional Syntax Rules.

Access Rules

No additional Access Rules.

General Rules

- 1) Insert before GR If the pass-through flag of the current SQL-session context is *True*, and the current SQL-session context includes an {SQL statement name : ExecutionHandle} pair whose SQL statement name is equivalent to <SQL statement name>, then:
 - a) Let *FSN* be the pass-through foreign server name included in the current SQL-session context. Let *WN* be the name of the foreign-data wrapper included in the foreign server descriptor of the foreign server identified by *FSN*. Let *WR* be the foreign-data wrapper identified by *WN*. Let *WRLN* be the name of the library identified in the foreign-data wrapper descriptor of *WR*. Let *EXH* be the ExecutionHandle associated with <SQL statement name>.
 - b) The `Close()` routine in the library identified by *WRLN* is invoked with *EXH* as argument.
 - c) No further General Rules of this Subclause are applied.

Conformance Rules

No additional Conformance Rules.

(Blank page)

18 Embedded SQL

This Clause modifies Clause 20, “Embedded SQL”, in ISO/IEC 9075-2.

18.1 <embedded SQL Ada program>

This Subclause modifies Subclause 20.3, “<embedded SQL Ada program>”, in ISO/IEC 9075-2.

Function

Specify an <embedded SQL Ada program>.

Format

```
<Ada derived type specification> ::=  
!! All alternatives from ISO/IEC 9075-2  
| <Ada DATALINK variable>  
  
<Ada DATALINK variable> ::= SQL TYPE IS <datalink type>
```

Syntax Rules

- 1) Insert after SR 5)j) The syntax

```
SQL TYPE IS <datalink type>
```

shall be replaced by

```
Interfaces.SQL.CHAR(1..MDL)
```

where *MDL* is the maximum datalink length, in any <Ada DATALINK variable>.

NOTE 46 — The term “maximum datalink length” is defined in Subclause 4.8, “Datalinks”.

Access Rules

No additional Access Rules.

General Rules

No additional General Rules.

Conformance Rules

- 1) Without Feature M003, “Datalinks via Embedded SQL”, conforming SQL language shall not contain an <Ada DATALINK variable>.
- 2) Without Feature M011, “Datalinks via Ada”, conforming SQL language shall not contain an <Ada DATALINK variable>.

18.2 <embedded SQL C program>

This Subclause modifies Subclause 20.4, “<embedded SQL C program>”, in ISO/IEC 9075-2.

Function

Specify an <embedded SQL C program>.

Format

```
<C derived variable> ::=  
!! All alternatives from ISO/IEC 9075-2  
| <C DATALINK variable>  
  
<C DATALINK variable> ::=  
SQL TYPE IS <datalink type> <C host identifier> [ <C initial value> ]  
[ { <comma> <C host identifier> [ <C initial value> ] }... ]
```

Syntax Rules

- 1) Insert after SR 5)m The syntax

```
SQL TYPE IS <datalink type>
```

shall be replaced by

```
char[MDL]
```

where *MDL* is the maximum datalink length, in any <C DATALINK variable>.

NOTE 47 — The term “maximum datalink length” is defined in Subclause 4.8, “Datalinks”.

Access Rules

No additional Access Rules.

General Rules

No additional General Rules.

Conformance Rules

- 1) Without Feature M003, “Datalinks via Embedded SQL”, conforming SQL language shall not contain a <C DATALINK variable>.
- 2) Without Feature M012, “Datalinks via C”, conforming SQL language shall not contain a <C DATALINK variable>.

18.3 <embedded SQL COBOL program>

This Subclause modifies Subclause 20.5, “<embedded SQL COBOL program>”, in ISO/IEC 9075-2.

Function

Specify an <embedded SQL COBOL program>.

Format

```
<COBOL derived type specification> ::=  
!! All alternatives from ISO/IEC 9075-2  
| <COBOL DATALINK variable>
```

```
<COBOL DATALINK variable> ::= [ USAGE [ IS ] ] SQL TYPE IS <datalink type>
```

Syntax Rules

- 1) Insert after SR 5)j) The syntax

```
SQL TYPE IS <datalink type>
```

shall be replaced by

```
PIC X(MDL) .
```

where *MDL* is the maximum datalink length, in any <COBOL DATALINK variable>.

NOTE 48 — The term “maximum datalink length” is defined in Subclause 4.8, “Datalinks”.

Access Rules

No additional Access Rules.

General Rules

No additional General Rules.

Conformance Rules

- 1) Without Feature M003, “Datalinks via Embedded SQL”, conforming SQL language shall not contain a <COBOL DATALINK variable>.
- 2) Without Feature M013, “Datalinks via COBOL”, conforming SQL language shall not contain a <COBOL DATALINK variable>.

18.4 <embedded SQL Fortran program>

This Subclause modifies Subclause 20.6, “<embedded SQL Fortran program>”, in ISO/IEC 9075-2.

Function

Specify an <embedded SQL Fortran program>.

Format

```
<Fortran derived type specification> ::=  
!! All alternatives from ISO/IEC 9075-2  
| <Fortran DATALINK variable>  
  
<Fortran DATALINK variable> ::= SQL TYPE IS <datalink type>
```

Syntax Rules

- 1) Insert after SR 6)j) The syntax

SQL TYPE IS <datalink type>

for a given <Fortran host identifier> *fhi* shall be replaced by

CHARACTER *fhi* * *MDL*

where *MDL* is the maximum datalink length, in any <Fortran DATALINK variable>.

NOTE 49 — The term “maximum datalink length” is defined in Subclause 4.8, “Datalinks”.

Access Rules

No additional Access Rules.

General Rules

No additional General Rules.

Conformance Rules

- 1) Without Feature M003, “Datalinks via Embedded SQL”, conforming SQL language shall not contain a <Fortran DATALINK variable>.
- 2) Without Feature M014, “Datalinks via Fortran”, conforming SQL language shall not contain a <Fortran DATALINK variable>.

18.5 <embedded SQL MUMPS program>

This Subclause modifies Subclause 20.7, “<embedded SQL MUMPS program>”, in ISO/IEC 9075-2.

Function

Specify an <embedded SQL MUMPS program>.

Format

```
<MUMPS derived type specification> ::=  
!! All alternatives from ISO/IEC 9075-2  
| <MUMPS DATALINK variable>  
  
<MUMPS DATALINK variable> ::= SQL TYPE IS <datalink type>
```

Syntax Rules

- 1) Insert after SR 9)i The syntax

SQL TYPE IS <datalink type>

for a given <MUMPS host identifier> *mhi* shall be replaced by

VARCHAR *mhi* *MDL*

where *MDL* is the maximum datalink length, in any <MUMPS DATALINK variable>.

NOTE 50 — The term “maximum datalink length” is defined in Subclause 4.8, “Datalinks”.

Access Rules

No additional Access Rules.

General Rules

No additional General Rules.

Conformance Rules

- 1) Without Feature M003, “Datalinks via Embedded SQL”, conforming SQL language shall not contain a <MUMPS DATALINK variable>.
- 2) Without Feature M015, “Datalinks via M”, conforming SQL language shall not contain a <MUMPS DATALINK variable>.

18.6 <embedded SQL Pascal program>

This Subclause modifies Subclause 20.8, “<embedded SQL Pascal program>”, in ISO/IEC 9075-2.

Function

Specify an <embedded SQL Pascal program>.

Format

```
<Pascal derived type specification> ::=  
!! All alternatives from ISO/IEC 9075-2  
| <Pascal DATALINK variable>  
  
<Pascal DATALINK variable> ::= SQL TYPE IS <datalink type>
```

Syntax Rules

- 1) Insert after SR 5)k The syntax

SQL TYPE IS <datalink type>

shall be replaced by

PACKED ARRAY [1..*MDL*] OF CHAR

where *MDL* is the maximum datalink length, in any <Pascal DATALINK variable>.

NOTE 51 — The term “maximum datalink length” is defined in Subclause 4.8, “Datalinks”.

Access Rules

No additional Access Rules.

General Rules

No additional General Rules.

Conformance Rules

- 1) Without Feature M003, “Datalinks via Embedded SQL”, conforming SQL language shall not contain a <Pascal DATALINK variable>.
- 2) Without Feature M016, “Datalinks via Pascal”, conforming SQL language shall not contain a <Pascal DATALINK variable>.

18.7 <embedded SQL PL/I program>

This Subclause modifies Subclause 20.9, “<embedded SQL PL/I program>”, in ISO/IEC 9075-2.

Function

Specify an <embedded SQL PL/I program>.

Format

```
<PL/I derived type specification> ::=  
!! All alternatives from ISO/IEC 9075-2  
| <PL/I DATALINK variable>  
  
<PL/I DATALINK variable> ::= SQL TYPE IS <datalink type>
```

Syntax Rules

- 1) Insert after SR 5)j) The syntax

SQL TYPE IS <datalink type>

shall be replaced by

CHARACTER (*MDL*)

where *MDL* is the maximum datalink length, in any <PL/I DATALINK variable>.

NOTE 52 — The term “maximum datalink length” is defined in Subclause 4.8, “Datalinks”.

Access Rules

No additional Access Rules.

General Rules

No additional General Rules.

Conformance Rules

- 1) Without Feature M003, “Datalinks via Embedded SQL”, conforming SQL language shall not contain a <PL/I DATALINK variable>.
- 2) Without Feature M017, “Datalinks via PL/I”, conforming SQL language shall not contain a <PL/I DATALINK variable>.

19 Call-Level Interface specifications

This Clause modifies Clause 5, “Call-Level Interface specifications”, in ISO/IEC 9075-3.

19.1 <CLI routine>

This Subclause modifies Subclause 5.1, “<CLI routine>”, in ISO/IEC 9075-3.

Function

Describe a generic SQL/CLI routine.

Format

```
<CLI routine> ::=  
!! All alternatives from ISO/IEC 9075-3  
| BuildDataLink  
| GetDataLinkAttr
```

Syntax Rules

- 1) *Table 13, “Abbreviated SQL/CLI generic names”, modifies Table 3, “Abbreviated SQL/CLI generic names”, in ISO/IEC 9075-3.*

Table 13 — Abbreviated SQL/CLI generic names

Generic Name	Abbreviation
	<i>All alternatives from ISO/IEC 9075-3</i>
BuildDataLink	BDL
GetDataLinkAttr	GDL

Access Rules

No additional Access Rules.

General Rules

No additional General Rules.

19.2 Implicit DESCRIBE USING clause

This Subclause modifies Subclause 5.5, “Implicit DESCRIBE USING clause”, in ISO/IEC 9075-3.

Function

Specify the rules for an implicit DESCRIBE USING clause.

General Rules

- 1) Insert after GR 5)c)iv)10) If TYPE indicates DATALINK, then LENGTH and OCTET_LENGTH are set to the maximum possible length in octets of the datalink.
- 2) Insert after GR 8)d)vi)10) If TYPE indicates DATALINK, then LENGTH and OCTET_LENGTH are set to the maximum possible length in octets of the datalink.

19.3 Description of CLI item descriptor areas

This Subclause modifies Subclause 5.13, “Description of CLI item descriptor areas”, in ISO/IEC 9075-3.

Function

Specify the identifiers, data types and codes for fields used in CLI item descriptor areas.

Syntax Rules

- 1) Insert after SR 5)c)xiii) TYPE indicates DATALINK.
- 2) Replace SR 7)c)iv) TYPE indicates DEFAULT, CHARACTER, CHARACTER LARGE OBJECT, CHARACTER LARGE OBJECT LOCATOR, BINARY LARGE OBJECT, BINARY LARGE OBJECT LOCATOR, SMALLINT, INTEGER, BIGINT, REAL, DOUBLE PRECISION, USER-DEFINED TYPE LOCATOR, REF, or DATALINK.
- 3) Insert after SR 12)c)ix) TYPE indicates DATALINK and one of the following is true:
 - a) NULL is true.
 - b) DEFERRED is true.
- 4) Replace SR 13)c)iv) TYPE indicates DEFAULT, CHARACTER, CHARACTER LARGE OBJECT, CHARACTER LARGE OBJECT LOCATOR, BINARY LARGE OBJECT, BINARY LARGE OBJECT

LOCATOR, SMALLINT, INTEGER, BIGINT, REAL, DOUBLE PRECISION, USER-DEFINED TYPE
 LOCATOR, REF, or DATALINK.

General Rules

- 1) *Table 14, “Codes used for implementation data types in SQL/CLI”, modifies Table 6, “Codes used for implementation data types in SQL/CLI”, in ISO/IEC 9075-3.*

Table 14 — Codes used for implementation data types in SQL/CLI

Data Type	Code
	<i>All alternatives from ISO/IEC 9075-3</i>
DATALINK	70

- 2) *Table 15, “Codes used for application data types in SQL/CLI”, modifies Table 7, “Codes used for application data types in SQL/CLI”, in ISO/IEC 9075-3.*

Table 15 — Codes used for application data types in SQL/CLI

Data Type	Code
	<i>All alternatives from ISO/IEC 9075-3</i>
DATALINK	70

19.4 Other tables associated with CLI

This Subclause modifies Subclause 5.14, “Other tables associated with CLI”, in ISO/IEC 9075-3.

Table 16, “Codes used to identify SQL/CLI routines”, modifies Table 27, “Codes used to identify SQL/CLI routines”, in ISO/IEC 9075-3.

Table 16 — Codes used to identify SQL/CLI routines

Generic Name	Code
	<i>All alternatives from ISO/IEC 9075-3</i>
BuildDataLink	1029
GetDataLinkAttr	1034

Table 17, “Codes and data types for implementation information”, modifies Table 28, “Codes and data types for implementation information”, in ISO/IEC 9075-3.

Table 17 — Codes and data types for implementation information

Information Type	Code	Data Type
<i>All alternatives from ISO/IEC 9075-3</i>		
MAXIMUM DATALINK LENGTH	20004	INTEGER

Table 18 — Codes used for datalink attributes

Attribute	Code
URL COMPLETE	3
URL PATH	4
URL PATH ONLY	5
URL SCHEME	6
URL SERVER	7
Implementation-defined datalink attribute	< 0

Table 19, “Data types of attributes”, modifies Table 19, “Data types of attributes”, in ISO/IEC 9075-3.

Table 19 — Data types of attributes

Attribute	Data type	Values
	<i>All alternatives from ISO/IEC 9075-3</i>	
URL COMPLETE	CHARACTER VARYING(L) ¹	Datalink complete URL
URL PATH	CHARACTER VARYING(L) ¹	Datalink URL path
URL PATH ONLY	CHARACTER VARYING(L) ¹	Datalink URL path only
URL SCHEME	CHARACTER VARYING(L) ¹	Datalink URL scheme
URL SERVER	CHARACTER VARYING(L) ¹	Datalink URL server

Attribute	Data type	Values
Implementation-defined datalink attribute	Implementation-defined data type	Implementation-defined value

¹ Where L is an implementation-defined integer not less than the maximum datalink length. (The term “maximum datalink length” is defined in Subclause 4.8, “Datalinks”.)

Conformance Rules

No additional Conformance Rules.

19.5 SQL/CLI data type correspondences

This Subclause modifies Subclause 5.15, “SQL/CLI data type correspondences”, in ISO/IEC 9075-3.

Function

Replace first paragraph Specify the SQL/CLI data type correspondences for SQL data types and host language types associated with the required parameter mechanisms, as shown in Table 2, “Supported calling conventions of SQL/CLI routines by language”, in ISO/IEC 9075-3.

Tables

Table 20, “SQL/CLI data type correspondences for Ada”, modifies Table 44, “SQL/CLI data type correspondences for Ada”, in ISO/IEC 9075-3.

Table 20 — SQL/CLI data type correspondences for Ada

SQL Data Type	Ada Data Type
All alternatives from ISO/IEC 9075-3	All alternatives from ISO/IEC 9075-3
DATALINK	SQL_STANDARD.CHAR, with PLength of LD ¹
¹ The length LD of the Ada character type corresponding with SQL data type DATALINK is implementation-defined.	

Table 21, “SQL/CLI data type correspondences for C”, modifies Table 45, “SQL/CLI data type correspondences for C”, in ISO/IEC 9075-3.

Table 21 — SQL/CLI data type correspondences for C

SQL Data Type	C Data Type
All alternatives from ISO/IEC 9075-3	All alternatives from ISO/IEC 9075-3
DATALINK	char, with length LD ³
³ The length LD of the C character type corresponding with SQL data type DATALINK is implementation-defined.	

Table 22, “SQL/CLI data type correspondences for COBOL”, modifies Table 46, “SQL/CLI data type correspondences for COBOL”, in ISO/IEC 9075-3.

Table 22 — SQL/CLI data type correspondences for COBOL

SQL Data Type	COBOL Data Type
<i>All alternatives from ISO/IEC 9075-3</i>	<i>All alternatives from ISO/IEC 9075-3</i>
DATALINK	alphanumeric, with length LD^3
³ The length LD of the COBOL character type corresponding with SQL data type DATALINK is implementation-defined.	

Table 23, “SQL/CLI data type correspondences for Fortran”, modifies Table 47, “SQL/CLI data type correspondences for Fortran”, in ISO/IEC 9075-3.

Table 23 — SQL/CLI data type correspondences for Fortran

SQL Data Type	Fortran Data Type
<i>All alternatives from ISO/IEC 9075-3</i>	<i>All alternatives from ISO/IEC 9075-3</i>
DATALINK	CHARACTER with length LD^2
² The length LD of the Fortran character type corresponding with SQL data type DATALINK is implementation-defined.	

Table 24, “SQL/CLI data type correspondences for M”, modifies Table 48, “SQL/CLI data type correspondences for M”, in ISO/IEC 9075-3.

Table 24 — SQL/CLI data type correspondences for M

SQL Data Type	MUMPS Data Type
<i>All alternatives from ISO/IEC 9075-3</i>	<i>All alternatives from ISO/IEC 9075-3</i>
DATALINK	character

Table 25, “SQL/CLI data type correspondences for Pascal”, modifies Table 49, “SQL/CLI data type correspondences for Pascal”, in ISO/IEC 9075-3.

Table 25 — SQL/CLI data type correspondences for Pascal

SQL Data Type	Pascal Data Type
<i>All alternatives from ISO/IEC 9075-3</i>	<i>All alternatives from ISO/IEC 9075-3</i>
DATALINK	PACKED ARRAY[1.. LD^2] OF CHAR

SQL Data Type	Pascal Data Type
² The length <i>LD</i> of the Pascal character type corresponding with SQL data type DATALINK is implementation-defined.	

Table 26, “SQL/CLI data type correspondences for PL/I”, modifies Table 50, “SQL/CLI data type correspondences for PL/I”, in ISO/IEC 9075-3.

Table 26 — SQL/CLI data type correspondences for PL/I

SQL Data Type	PL/I Data Type
<i>All alternatives from ISO/IEC 9075-3</i>	<i>All alternatives from ISO/IEC 9075-3</i>
DATALINK	CHARACTER VARYING(<i>LD</i>), where <i>LD</i> is implementation-defined

20 SQL/CLI routines

This Clause modifies Clause 6, “SQL/CLI routines”, in ISO/IEC 9075-3.

20.1 BuildDataLink

Function

Build a datalink value.

Definition

```
BuildDataLink (
    StatementHandle      IN  INTEGER,
    DataLocation         IN  CHARACTER(L1),
    DataLocationLength  IN  INTEGER,
    DataLink             OUT CHARACTER(L2),
    BufferLength         IN  INTEGER,
    StringLength        OUT INTEGER )
RETURNS SMALLINT
```

where *L1* has a maximum value equal to the implementation-defined maximum length of a variable-length character string and *L2* has a maximum value equal to the implementation-defined maximum length of a datalink.

General Rules

- 1) Let *SH* be the value of StatementHandle.
NOTE 53 — *SH* is used only if BuildDataLink issues a completion or exception condition.
- 2) Let *DL* be the datalink value whose File Reference is DataLocation.
NOTE 54 — *File Reference* is defined in Subclause 4.8, “Datalinks”.
- 3) Let *DLL* be the length in octets of *DL*.
- 4) If *DLL* is greater than the maximum datalink length, then an exception condition is raised: *CLI-specific condition* — *invalid datalink value*.
NOTE 55 — The term “maximum datalink length” is defined in Subclause 4.8, “Datalinks”.
- 5) Apply the General Rules of Subclause 5.9, “Character string retrieval”, in ISO/IEC 9075-3 with DataLink, *DL*, BufferLength, and StringLength as *TARGET*, *VALUE*, *OCTET LENGTH*, and *RETURNED OCTET LENGTH*, respectively.

Conformance Rules

- 1) Without Feature M002, “Datalinks via SQL/CLI”, conforming SQL language shall not contain Build-DataLink().

20.2 GetDataLinkAttr

Function

Retrieve the value of a datalink attribute.

Definition

```
GetDataLinkAttr (
    StatementHandle      IN  INTEGER,
    Attribute            IN  SMALLINT,
    DataLink             IN  CHARACTER(L),
    DataLinkLength      IN  INTEGER,
    Value                OUT ANY,
    BufferLength         IN  INTEGER,
    StringLength        OUT INTEGER )
RETURNS SMALLINT
```

where *L* has a maximum value equal to the implementation-defined maximum length of a datalink.

General Rules

- 1) Let *SH* be the value of StatementHandle.
NOTE 56 — *SH* is used only if GetDataLinkAttr issues a completion or exception condition.
- 2) Let *A* be the value of Attribute.
- 3) If *A* is not one of the code values in Table 18, “Codes used for datalink attributes”, then an exception condition is raised: *CLI-specific condition — invalid attribute identifier*.
- 4) Let *DLL* be the value of DataLinkLength.
- 5) Case:
 - a) If *DLL* is not negative, then let *DL* be the first *DLL* octets of Datalink.
 - b) Otherwise, an exception condition is raised: *CLI-specific condition — invalid string length or buffer length*.
- 6) Let *ML* be the implementation-defined maximum length in characters of a datalink value.
- 7) If *DL* is not a valid datalink value, then an exception condition is raised: *CLI-specific condition — invalid datalink value*.
- 8) Let *BL* be the value of BufferLength.
- 9) If *A* specifies an implementation-defined datalink attribute, then
Case:

20.2 GetDataLinkAttr

- a) If the data type for the datalink attribute is specified as INTEGER in Table 19, “Data types of attributes”, then Value is set to the value of the implementation-defined datalink attribute and no further General Rules of this Subclause are applied.
- b) Otherwise:
 - i) Let *AV* be the value of the implementation-defined datalink attribute.
 - ii) The General Rules of Subclause 5.9, “Character string retrieval”, in ISO/IEC 9075-3 are applied with Value, *AV*, *BL*, and StringLength as *TARGET*, *VALUE*, *OCTET LENGTH*, and *RETURNED OCTET LENGTH*, respectively.

10) Case:

- a) If *A* indicates URL COMPLETE, then *AV* is set to the value of the File Reference of *DL*.
- b) If *A* indicates URL PATH, then *AV* is set to the value of the path of *DL*, possibly combined with an access token under the General Rules of Subclause 6.4, “<string value function>”.
- c) If *A* indicates URL PATH ONLY, then *AV* is set to the value of the path of *DL*.
- d) If *A* indicates URL SCHEME, then *AV* is set to the value of the scheme of *DL*.
- e) If *A* indicates URL SERVER, then *AV* is set to the value of the host of *DL*.

NOTE 57 — “host”, “scheme”, and “path” are defined in Subclause 6.6, “<datalink value function>”.

- 11) The General Rules of Subclause 5.9, “Character string retrieval”, in ISO/IEC 9075-3 are applied with Value, *AV*, *BL*, and StringLength as *TARGET*, *VALUE*, *OCTET LENGTH*, and *RETURNED OCTET LENGTH*, respectively.

Conformance Rules

- 1) Without Feature M002, “Datalinks via SQL/CLI”, conforming SQL language shall not contain Get-DataLinkAttr().

20.3 GetInfo

This Subclause modifies Subclause 6.38, “GetInfo”, in ISO/IEC 9075-3.

Function

Get information about the implementation.

Definition

No additional Definition.

General Rules

- 1) Insert into the dashed list in [GR 10](#)
— MAXIMUM DATALINK LENGTH

Conformance Rules

- 1) Without Feature M002, “Datalinks via SQL/CLI”, in conforming SQL language, the value of InfoType shall not indicate MAXIMUM DATALINK LENGTH.

(Blank page)

21 SQL/MED common specifications

21.1 Description of foreign-data wrapper item descriptor areas

Function

Specify the identifiers, data types and codes for fields used in foreign-data wrapper item descriptor areas.

Syntax Rules

- 1) A foreign-data wrapper item descriptor area consists of the fields specified in Table 4, “Fields in foreign-data wrapper descriptor areas”.
- 2) Let *HL1* be the standard host language in which the SQL-server is written and let *HL2* be the standard host language in which the foreign-data wrapper is written.
- 3) Given a foreign-data wrapper item descriptor area *IDA* in which the value of LEVEL is some value *N*, the immediately subordinate descriptor areas of *IDA* are those foreign-data wrapper item descriptor areas in which the value of LEVEL is *N+1* and whose position in the foreign-data wrapper descriptor area follows that of *IDA* and precedes that of any foreign-data wrapper item descriptor area in which the value of LEVEL is less than *N+1*. The subordinate descriptor areas of *IDA* are those foreign-data wrapper item descriptor areas that are immediately subordinate descriptor areas of *IDA* or that are subordinate descriptor areas of a foreign-data wrapper item descriptor area that is immediately subordinate to *IDA*.
- 4) Given a data type *DT* and its descriptor *DE*, the immediately subordinate descriptors of *DE* are defined to be

Case:

 - a) If *DT* is ROW, then the field descriptors of the fields of *DT*. The *i*-th immediately subordinate descriptor is the descriptor of the *i*-th field of *DT*.
 - b) If *DT* is ARRAY or MULTISSET, then the descriptor of the associated element type of *DT*. The subordinate descriptors of *DE* are those descriptors that are immediately subordinate descriptors of *DE* or that are subordinate descriptors of a descriptor that is immediately subordinate to *DE*.
- 5) Given a descriptor *DE*, let *SDE_j* represent its *j*-th immediately subordinate descriptor. There is an implied ordering of the subordinate descriptors of *DE*, such that:
 - a) *SDE₁* is in the first ordinal position.
 - b) The ordinal position of *SDE_{j+1}* is *K+NS+1*, where *K* is the ordinal position of *SDE_j* and *NS* is the number of subordinate descriptors of *SDE_j*. The implicitly ordered subordinate descriptors of *SDE_j* occupy contiguous ordinal positions starting at position *K+1*.

21.1 Description of foreign-data wrapper item descriptor areas

- 6) Let *HL* be the standard programming language of the invoking SQL-server. Let *operative data type correspondence table* be the data type correspondence table for *HL* as specified in Subclause 19.5, “SQL/CLI data type correspondences”. Refer to the two columns of the operative data type correspondence table as the *SQL data type column* and the *host data type column*.
- 7) A foreign-data wrapper item descriptor area *IDA* in a foreign-data wrapper descriptor area that is a server row descriptor or a server parameter descriptor is *consistent* if and only if all of the following are true:
 - a) TYPE indicates ROW or is one of the code values in Table 15, “Codes used for application data types in SQL/CLI”.
 - b) Exactly one of the following is true:
 - i) TYPE indicates NUMERIC, and PRECISION and SCALE are valid precision and scale values for the NUMERIC data type.
 - ii) TYPE indicates DECIMAL, and PRECISION and SCALE are valid precision and scale values for the DECIMAL data type.
 - iii) TYPE indicates DEFAULT, CHARACTER, CHARACTER LARGE OBJECT, CHARACTER LARGE OBJECT LOCATOR, BINARY LARGE OBJECT, BINARY LARGE OBJECT LOCATOR, SMALLINT, INTEGER, BIGINT, REAL, DOUBLE PRECISION, BOOLEAN, USER-DEFINED TYPE LOCATOR, REF, or DATALINK.
 - iv) TYPE indicates FLOAT, and PRECISION is a valid precision value for the FLOAT data type.
 - v) TYPE indicates ROW and, where *N* is the value of the DEGREE field, there are exactly *N* immediately subordinate descriptor areas of *IDA*, and those item descriptor areas are valid.
 - vi) TYPE indicates ARRAY LOCATOR or MULTISET LOCATOR, there is exactly 1 (one) immediately subordinate descriptor area of *IDA*, and that item descriptor area is valid.
 - vii) TYPE indicates an implementation-defined data type.
- 8) Let *IDA* be a foreign-data wrapper item descriptor area in a server parameter descriptor.
- 9) If the value of INDICATOR is the appropriate 'Code' for SQL NULL DATA in Table 26, “Miscellaneous codes used in CLI”, in ISO/IEC 9075-3, then NULL is true for *IDA*. Otherwise, NULL is false for *IDA*.
- 10) *IDA* is *valid* if and only if:
 - a) TYPE is one of the code values in Table 15, “Codes used for application data types in SQL/CLI”, or TYPE indicates ROW.
 - b) If LEVEL is 0 (zero) for *IDA*, then let *TLC* be the value of TOP_LEVEL_COUNT in the server parameter descriptor associated with *IDA*. *IDA* shall be one of exactly *TLC* item descriptor areas in the server parameter descriptor.
 - c) One of the following is true:

Case:

 - i) TYPE indicates CHARACTER, CHARACTER LARGE OBJECT, or BINARY LARGE OBJECT, and the value *V* of OCTET_LENGTH is greater than zero, and

Case:

21.1 Description of foreign-data wrapper item descriptor areas

- 1) If *HL1* and *HL2* are both pointer-supporting languages, then the number of characters wholly contained in the first *V* octets of the host variable addressed by *DATA_POINTER* is a valid length value for a CHARACTER, CHARACTER LARGE OBJECT, or BINARY LARGE OBJECT data type, as indicated by *TYPE*.
 - 2) Otherwise, the number of characters wholly contained in the first *V* octets of *DATA* is a valid length value for a CHARACTER, CHARACTER LARGE OBJECT, or BINARY LARGE OBJECT data type, as indicated by *TYPE*.
- ii) *TYPE* indicates CHARACTER LARGE OBJECT LOCATOR, BINARY LARGE OBJECT LOCATOR, or USER-DEFINED TYPE LOCATOR.
 - iii) *TYPE* indicates NUMERIC, and *PRECISION* and *SCALE* are valid precision and scale values for the NUMERIC data type.
 - iv) *TYPE* indicates DECIMAL, and *PRECISION* and *SCALE* are valid precision and scale values for the DECIMAL data type.
 - v) *TYPE* indicates SMALLINT, INTEGER, BIGINT, REAL, or DOUBLE PRECISION.
 - vi) *TYPE* indicates FLOAT, and *PRECISION* is a valid precision value for the FLOAT data type.
 - vii) *TYPE* indicates REF.
 - viii) *TYPE* indicates DATALINK.
 - ix) *TYPE* indicates ROW and, where *N* is the value of the DEGREE field, there are exactly *N* immediately subordinate foreign-data wrapper descriptor areas of *IDA*, and those foreign-data wrapper item descriptor areas are valid.
 - x) *TYPE* indicates ARRAY LOCATOR or MULTISSET LOCATOR, there is exactly 1 (one) immediately subordinate descriptor area of *IDA*, and that subordinate descriptor area is valid.
 - xi) *TYPE* indicates an implementation-defined data type.
- d) Case:
- i) If *HL1* and *HL2* are both pointer-supporting languages, then one of the following is true:
 - 1) *DATA_POINTER* is zero and NULL is true.
 - 2) *DATA_POINTER* is not zero and the value of the host variable addressed by *DATA_POINTER* is a valid value of the data type indicated by *TYPE*.
 - ii) Otherwise, *DATA* is a valid value of the data type indicated by *TYPE*.
- 11) A foreign-data wrapper item descriptor area *IDA* in a server row descriptor is valid if and only if:
- a) *TYPE* is one of the code values in Table 15, “Codes used for application data types in SQL/CLI”, or *TYPE* indicates ROW.
 - b) If *LEVEL* is 0 (zero) for *IDA*, then let *TLC* be the value of *TOP_LEVEL_COUNT* in the server row descriptor associated with *IDA*. *IDA* shall be one of exactly *TLC* foreign-data wrapper item descriptor areas in the server row descriptor.
 - c) One of the following is true:

Case:

21.1 Description of foreign-data wrapper item descriptor areas

- i) TYPE indicates NUMERIC, and PRECISION and SCALE are valid precision and scale values for the NUMERIC data type.
- ii) TYPE indicates DECIMAL, and PRECISION and SCALE are valid precision and scale values for the DECIMAL data type.
- iii) TYPE indicates FLOAT, and PRECISION is a valid precision value for the FLOAT data type.
- iv) TYPE indicates CHARACTER, CHARACTER LARGE OBJECT, CHARACTER LARGE OBJECT LOCATOR, BINARY LARGE OBJECT, BINARY LARGE OBJECT LOCATOR, SMALLINT, INTEGER, BIGINT, REAL, DOUBLE PRECISION, BOOLEAN, USER-DEFINED TYPE LOCATOR, REF, or DATALINK.
- v) TYPE indicates ROW and, where *N* is the value of the DEGREE field, there are exactly *N* immediately subordinate descriptor areas of *IDA*, and those subordinate descriptor areas are valid.
- vi) TYPE indicates ARRAY LOCATOR or MULTISSET LOCATOR, there is exactly 1 (one) immediately subordinate descriptor area of *IDA*, and that subordinate descriptor area is valid.
- vii) TYPE indicates an implementation-defined data type.

General Rules

None.

Conformance Rules

None.

21.2 Implicit cursor

Function

Specify the rules for an implicit DECLARE CURSOR and OPEN statement.

General Rules

- 1) Let *AE* be an *ALLOCATED FDW-EXECUTION* specified in an application of this Subclause.
- 2) If there is no cursor effectively associated with *AE*, then a cursor is effectively associated with *AE* and the cursor name associated with *AE* becomes the name of the cursor.
- 3) Let *CT* be 'NO SCROLL'.
- 4) Let *CS* be 'ASENSITIVE'.
- 5) Let *CH* be 'WITHOUT HOLD'.
- 6) Let *SS* be the SQL-statement that is effectively associated with *AE*.
- 7) Let *CN* be the name of the cursor effectively associated with *AE* and let *CR* be the following <declare cursor>:

```
DECLARE CN CS CT CURSOR CH FOR SS
```

- 8) Cursor *CN* is effectively opened in the following steps:
 - a) A copy of *SS* is effectively created in which:
 - i) Each <dynamic parameter specification> is replaced by the value of the corresponding dynamic parameter.
 - ii) Each <value specification> generally contained in *SS* that is *CURRENT_USER*, *CURRENT_ROLE*, *SESSION_USER*, *SYSTEM_USER*, *CURRENT_CATALOG*, *CURRENT_SCHEMA*, *CURRENT_PATH*, *CURRENT_DEFAULT_TRANSFORM_GROUP*, or *CURRENT_TRANSFORM_GROUP_FOR_TYPE* <path-resolved user-defined type name> is effectively replaced by the value resulting from evaluation of *CURRENT_USER*, *CURRENT_ROLE*, *SESSION_USER*, *SYSTEM_USER*, *CURRENT_CATALOG*, *CURRENT_SCHEMA*, *CURRENT_PATH*, *CURRENT_DEFAULT_TRANSFORM_GROUP*, or *CURRENT_TRANSFORM_GROUP_FOR_TYPE* <path-resolved user-defined type name>, respectively, with all such evaluations effectively done at the same instant in time.
 - iii) Each <datetime value function> generally contained in *SS* is effectively replaced by the value resulting from evaluation of that <datetime value function>, with all such evaluations effectively done at the same instant in time.
 - b) Let *T* be the table specified by the copy of *SS*.
 - c) A table descriptor for *T* is effectively created.
 - d) The General Rules of Subclause 14.1, “<declare cursor>”, in ISO/IEC 9075-2, are effectively applied to *CR*.

21.2 Implicit cursor

- e) Cursor *CN* is effectively placed in the open state and its position is before the first row of *T*.

Conformance Rules

None.

21.3 Implicit DESCRIBE INPUT USING clause

Function

Populate a specified descriptor area with information about the input values required to execute a foreign server request.

General Rules

- 1) Let *S* and *DESC* be a *SOURCE* and a *DESCRIPTOR* specified in the rules of this Subclause.
- 2) Let *HL* be the standard programming language of the invoking SQL-server.
- 3) The value of *DYNAMIC_FUNCTION* and *DYNAMIC_FUNCTION_CODE* in *DESC* are respectively a character string representation of the foreign server request and a numeric code that identifies the foreign server request, and are set to the value of the 'Identifier' and 'Code' columns, respectively, of the row in Table 36, "SQL-statement codes", that identifies in the 'SQL-statement' column the foreign server request.
- 4) A descriptor for the <dynamic parameter specification>s for the foreign server request is stored in *DESC* as follows:
 - a) Let *D* be the number of <dynamic parameter specification>s in *S*. Let NS_i , $1 \text{ (one)} \leq i \leq D$, be the number of subordinate descriptors of the descriptor for the *i*-th input dynamic parameter.
 - b) *TOP_LEVEL_COUNT* is set to *D*. If *D* is 0 (zero), then let *TD* be 0 (zero); otherwise, let *TD* be $D + \sum_{i=1}^D (NS_i)$. *COUNT* is set to *TD*.
NOTE 58 — The *KEY_TYPE* field is not relevant in this case.
 - c) If *TD* is zero, then no item descriptor areas are set. Otherwise, the first *TD* item descriptor areas are set so that the *i*-th item descriptor area contains a descriptor of the *j*-th <dynamic parameter specification> such that:
 - i) The descriptor for the first such <dynamic parameter specification> is assigned to the first descriptor area.
 - ii) The descriptor for the *j*+1-th <dynamic parameter specification> is assigned to the $i+NS_j+1$ -th item descriptor area.
 - iii) The implicitly ordered subordinate descriptors for the *j*-th <dynamic parameter specification>, if any, are assigned to contiguous item descriptor areas starting at the $i+1$ -th item descriptor area.
 - d) The descriptor of a <dynamic parameter specification> consists of values for *LEVEL*, *TYPE*, *NUL-LABLE*, *NAME*, *UNNAMED*, *PARAMETER_MODE*, *PARAMETER_ORDINAL_POSITION*, *PARAMETER_SPECIFIC_CATALOG*, *PARAMETER_SPECIFIC_SCHEMA*, *PARAMETER_SPECIFIC_NAME*, and other fields depending on the value of *TYPE* as described below. Those fields and fields that are not applicable for a particular value of *TYPE* are set to implementation-dependent values. The *DATA*, *DATA_POINTER*, *INDICATOR*, *OCTET_LENGTH*, *RETURNED_CARDINALITY*, and *KEY_MEMBER* fields are not relevant in this case.

21.3 Implicit DESCRIBE INPUT USING clause

- i) If the item descriptor area is set to a descriptor that is immediately subordinate to another whose LEVEL value is some value k , then LEVEL is set to $k+1$; otherwise, LEVEL is set to 0 (zero).
- ii) TYPE is set to a code as shown in Table 6, “Codes used for implementation data types in SQL/CLI”, in ISO/IEC 9075-3, indicating the data type of the <dynamic parameter specification> or subordinate descriptor.
- iii) NULLABLE is set to 1 (one).
NOTE 59 — This indicates that the <dynamic parameter specification> can have the null value.
- iv) KEY_MEMBER is set to 0 (zero).
- v) UNNAMED is set to 1 (one) and NAME is set to an implementation-dependent value.
- vi) Case:
 - 1) If TYPE indicates a <character string type>, then: LENGTH is set to the length or maximum length in characters of the character string and OCTET_LENGTH is set to the maximum possible length in octets of the character string; CHARACTER_SET_CATALOG, CHARACTER_SET_SCHEMA, and CHARACTER_SET_NAME are set to the <character set name> of the character string's character set; COLLATION_CATALOG, COLLATION_SCHEMA, and COLLATION_NAME are set to the <collation name> of the character string's collation.
 - 2) If TYPE indicates a <binary string type>, then LENGTH is set to the maximum length in octets of the binary string.
 - 3) If TYPE indicates an <exact numeric type>, then PRECISION and SCALE are set to the precision and scale of the exact numeric.
 - 4) If TYPE indicates an <approximate numeric type>, then PRECISION is set to the precision of the approximate numeric.
 - 5) If TYPE indicates a <datetime type>, then LENGTH is set to the length in positions of the datetime type, DATETIME_INTERVAL_CODE is set to a code as specified in Table 8, “Codes associated with datetime data types in SQL/CLI”, in ISO/IEC 9075-3, to indicate the specific datetime data type and PRECISION is set to the <time precision> or <timestamp precision> if either is applicable.
 - 6) If TYPE indicates INTERVAL, then LENGTH is set to the length in positions of the interval type, DATETIME_INTERVAL_CODE is set to a code as specified in Table 9, “Codes associated with <interval qualifier> in SQL/CLI”, in ISO/IEC 9075-3, to indicate the specific <interval qualifier>, DATETIME_INTERVAL_PRECISION is set to the <interval leading field precision>, and PRECISION is set to the <interval fractional seconds precision>, if applicable.
 - 7) If TYPE indicates REF, then LENGTH and OCTET_LENGTH are set to the length in octets of the <reference type>, USER_DEFINED_TYPE_CATALOG, USER_DEFINED_TYPE_SCHEMA, and USER_DEFINED_TYPE_NAME are set to the <user-defined type name> of the <reference type>, and SCOPE_CATALOG, SCOPE_SCHEMA, and SCOPE_NAME are set to the qualified name of the referenceable base table.
 - 8) If TYPE indicates USER-DEFINED TYPE, then USER_DEFINED_TYPE_CATALOG, USER_DEFINED_TYPE_SCHEMA, and USER_DEFINED_TYPE_NAME are set to the

<user-defined type name> of the user-defined type. SPECIFIC_TYPE_CATALOG, SPECIFIC_TYPE_SCHEMA, and SPECIFIC_TYPE_NAME are set to the <user-defined type name> of the user-defined type and CURRENT_TRANSFORM_GROUP is set to the CURRENT_TRANSFORM_GROUP_FOR_TYPE <user-defined type name>.

- 9) If TYPE indicates ROW, then DEGREE is set to the degree of the row type.
- 10) If TYPE indicates ARRAY, then CARDINALITY is set to the maximum cardinality of the array type.
- 11) If TYPE indicates DATALINK, then LENGTH and OCTET_LENGTH are set to the maximum possible length in octets of the datalink.

Conformance Rules

None.

21.4 Implicit DESCRIBE OUTPUT USING clause

Function

Populate a specified descriptor area with information about the values returned by an execution of a foreign server request.

General Rules

- 1) Let *S* and *DESC* be a *SOURCE* and a *DESCRIPTOR* specified in the rules of this Subclause.
- 2) Let *HL* be the standard programming language of the invoking SQL-server.
- 3) The value of *DYNAMIC_FUNCTION* and *DYNAMIC_FUNCTION_CODE* in *DESC* are respectively a character string representation of the foreign server request and a numeric code that identifies the foreign server request, and are set to the value of the 'Identifier' and 'Code' columns, respectively, of the row in Table 36, "SQL-statement codes", that identifies in the 'SQL-statement' column the foreign server request.
- 4) A representation of the column descriptors of the <select list> columns for the foreign server request is stored in *DESC* as follows:
 - a) Case:
 - i) If there is a select source associated with *DESC*, then:
 - 1) Let *TBL* be the table defined by *S* and let *D* be the degree of *TBL*. Let NS_i , $1 \text{ (one)} \leq i \leq D$, be the number of subordinate descriptors of the descriptor for the *i*-th column of *T*.
 - 2) *TOP_LEVEL_COUNT* is set to *D*. If *D* is 0 (zero), then let *TD* be 0 (zero); otherwise, let TD be $D + \sum_{i=1}^D (NS_i)$. *COUNT* is set to *TD*.
 - 3) Case:
 - A) If some subset of *SL* is the primary key of *TBL*, then *KEY_TYPE* is set to 1 (one).
 - B) If some subset of *SL* is the preferred key of *TBL*, then *KEY_TYPE* is set to 2.
 - C) Otherwise, *KEY_TYPE* is set to 0 (zero).
 - ii) Otherwise:
 - 1) Let *D* be 0 (zero). Let *TD* be 0 (zero).
 - 2) *KEY_TYPE* is set to 0 (zero).
 - b) If *TD* is zero, then no item descriptor areas are set. Otherwise, the first *TD* item descriptor areas are set so that the *i*-th item descriptor area contains a descriptor of the *j*-th column such that:
 - i) The descriptor for the first such column is assigned to the first descriptor area.
 - ii) The descriptor for the *j*+1-th column is assigned to the $i+NS_j+1$ -th item descriptor area.
 - iii) The implicitly ordered subordinate descriptors for the *j*-th column, if any, are assigned to contiguous item descriptor areas starting at the *i*+1-th item descriptor area.

- c) The descriptor of a column consists of values for LEVEL, TYPE, NULLABLE, NAME, UNNAMED, KEY_MEMBER, and other fields depending on the value of TYPE as described below. Those fields and fields that are not applicable for a particular value of TYPE are set to implementation-dependent values. The DATA, DATA_POINTER, INDICATOR, and OCTET_LENGTH fields are not relevant in this case.
- i) If the item descriptor area is set to a descriptor that is immediately subordinate to another whose LEVEL value is some value k , then LEVEL is set to $k+1$; otherwise, LEVEL is set to 0 (zero).
 - ii) TYPE is set to a code as shown in Table 6, “Codes used for implementation data types in SQL/CLI”, in ISO/IEC 9075-3, indicating the data type of the column or subordinate descriptor.
 - iii) Case:
 - 1) If the value of LEVEL is 0 (zero), then:
 - A) If the resulting column is possibly nullable, then NULLABLE is set to 1 (one); otherwise NULLABLE is set to 0 (zero).
 - B) If the column name is implementation-dependent, then NAME is set to the implementation-dependent name of the column and UNNAMED is set to 1 (one); otherwise, NAME is set to the <derived column> name for the column and UNNAMED is set to 0 (zero).
 - C) Case:
 - I) If a <select list> column C is a member of a primary or preferred key of TBL , then KEY_MEMBER is set to 1 (one).
 - II) Otherwise, KEY_MEMBER is set to 0 (zero).
 - 2) Otherwise:
 - A) NULLABLE is set to 1 (one).
 - B) Case:
 - I) If the item descriptor area describes a field of a row, then

Case:

 - 1) If the name of the field is implementation-dependent, then NAME is set to the implementation-dependent name of the field and UNNAMED is set to 1 (one).
 - 2) Otherwise, NAME is set to the name of the field and UNNAMED is set to 0 (zero).
 - II) Otherwise, UNNAMED is set to 1 (one) and NAME is set to an implementation-dependent value.
 - C) KEY_MEMBER is set to 0 (zero).
 - iv) Case:
 - 1) If TYPE indicates a <character string type>, then: LENGTH is set to the length or maximum length in characters of the character string and OCTET_LENGTH is set to the maximum possible length in octets of the character string; CHARACTER_SET_CATALOG, CHARACTER_SET_SCHEMA, and CHARACTER_SET_NAME are set to the <character set

21.4 Implicit DESCRIBE OUTPUT USING clause

name> of the character string's character set; COLLATION_CATALOG, COLLATION_SCHEMA, and COLLATION_NAME are set to the <collation name> of the character string's collation.

- 2) If TYPE indicates a <binary string type>, then LENGTH is set to the maximum length in octets of the binary string.
- 3) If TYPE indicates an <exact numeric type>, then PRECISION and SCALE are set to the precision and scale of the exact numeric.
- 4) If TYPE indicates an <approximate numeric type>, then PRECISION is set to the precision of the approximate numeric.
- 5) If TYPE indicates a <datetime type>, then LENGTH is set to the length in positions of the datetime type, DATETIME_INTERVAL_CODE is set to a code as specified in Table 8, “Codes associated with datetime data types in SQL/CLI”, in ISO/IEC 9075-3, to indicate the specific datetime data type and PRECISION is set to the <time precision> or <timestamp precision> if either is applicable.
- 6) If TYPE indicates INTERVAL, then LENGTH is set to the length in positions of the interval type, DATETIME_INTERVAL_CODE is set to a code as specified in Table 9, “Codes associated with <interval qualifier> in SQL/CLI”, in ISO/IEC 9075-3, to indicate the specific <interval qualifier>, DATETIME_INTERVAL_PRECISION is set to the <interval leading field precision>, and PRECISION is set to the <interval fractional seconds precision>, if applicable.
- 7) If TYPE indicates REF, then LENGTH and OCTET_LENGTH are set to the length in octets of the <reference type>, USER_DEFINED_TYPE_CATALOG, USER_DEFINED_TYPE_SCHEMA, and USER_DEFINED_TYPE_NAME are set to the <user-defined type name> of the <reference type>, and SCOPE_CATALOG, SCOPE_SCHEMA, and SCOPE_NAME are set to the qualified name of the referenceable base table.
- 8) If TYPE indicates USER-DEFINED TYPE, then USER_DEFINED_TYPE_CATALOG, USER_DEFINED_TYPE_SCHEMA, and USER_DEFINED_TYPE_NAME are set to the <user-defined type name> of the user-defined type. SPECIFIC_TYPE_CATALOG, SPECIFIC_TYPE_SCHEMA, and SPECIFIC_TYPE_NAME are set to the <user-defined type name> of the user-defined type and CURRENT_TRANSFORM_GROUP is set to the CURRENT_TRANSFORM_GROUP_FOR_TYPE <user-defined type name>.
- 9) If TYPE indicates ROW, then DEGREE is set to the degree of the row type.
- 10) If TYPE indicates ARRAY, then CARDINALITY is set to the maximum cardinality of the array type.
- 11) If TYPE indicates DATALINK, then LENGTH and OCTET_LENGTH are set to the maximum possible length in octets of the datalink.

Conformance Rules

None.

21.5 Implicit EXECUTE USING and OPEN USING clauses

Function

Specify the rules for an implicit EXECUTE USING clause and an implicit OPEN USING clause.

General Rules

- 1) Let *T* and *AE* be a *TYPE* and *ALLOCATED FWD-EXECUTION* specified in the rules of this Subclause.
- 2) Let *HL1* be the standard host language in which the SQL-server is written and let *HL2* be the standard host language in which the foreign-data wrapper is written.
- 3) Let *WPD* and *SPD* be the wrapper parameter descriptor and server parameter descriptor, respectively, for *AE*.
- 4) *WPD* and *SPD* describe the <dynamic parameter specification>s and <dynamic parameter specification> values, respectively, for the foreign server request being executed. Let *NSPD* be the value of COUNT for *SPD* and let *NWPD* be the value of COUNT for *WPD*.
 - a) If *NSPD* is less than zero, then an exception condition is raised: *dynamic SQL error — invalid descriptor count*.
 - b) Let *AD* be the minimum of *NSPD* and *NWPD*.
 - c) For each of the first *AD* item descriptor areas of *SPD*, if *TYPE* indicates DEFAULT, then:
 - i) Let *TP*, *P*, and *SC* be the values of the *TYPE*, *PRECISION*, and *SCALE* fields, respectively, for the corresponding item descriptor area of *WPD*.
 - ii) The data type, precision, and scale of the described <dynamic parameter specification> value (or part thereof, if the item descriptor area is a subordinate descriptor) are set to *TP*, *P*, and *SC*, respectively, for the purposes of this invocation only.
 - d) If the first *AD* item descriptor areas of *SPD* are not valid as specified in Subclause 21.1, “Description of foreign-data wrapper item descriptor areas”, then an exception condition is raised: *dynamic SQL error — using clause does not match dynamic parameter specifications*.
 - e) For the first *AD* item descriptor areas in *SPD*:
 - i) If the number of item descriptor areas in which the value of *LEVEL* is 0 (zero) is not *NWPD*, then an exception condition is raised: *dynamic SQL error — using clause does not match dynamic parameter specifications*.
 - ii) If all of the following are true, then an exception condition is raised: *dynamic SQL error — using clause does not match dynamic parameter specifications*.
 - 1) The value of *INDICATOR* is not negative.
 - 2) Either of the following is true:
 - A) *TYPE* does not indicate ROW and the item descriptor area is not subordinate to an item descriptor area for which the value of *INDICATOR* is not negative.
 - B) *TYPE* indicates ARRAY, ARRAY LOCATOR, MULTISSET, or MULTISSET LOCATOR.

C) Case:

- I) If *HL1* and *HL2* are both pointer-supporting languages, then the value of the host variable addressed by *DATA_POINTER* is not a valid value of the data type represented by the item descriptor area.
- II) Otherwise, the value of *DATA* is not a valid value of the data type represented by the item descriptor area.

f) Let *IDA* be the *i*-th item descriptor area of *SPD* whose *LEVEL* value is 0 (zero). Let *SDT* be the data type represented by *IDA*. The associated value of *IDA*, denoted by *SV*, is defined as follows.

Case:

i) If *NULL* is true for *IDA*, then *SV* is the null value.

ii) If *TYPE* indicates *ROW*, then *SV* is a row whose type is *SDT* and whose field values are the associated values of the immediately subordinate descriptor areas of *IDA*.

iii) Otherwise:

1) Case:

A) If *HL1* and *HL2* are both pointer-supporting languages, then let *V* be the value of the host variable addressed by *DATA_POINTER*.

B) Otherwise, let *V* be the value of *DATA*.

2) Case:

A) If *TYPE* indicates *CHARACTER*, then let *Q* be the value of *OCTET_LENGTH* and let *L* be the number of characters wholly contained in the first *Q* octets of *V*.

B) Otherwise, let *L* be zero.

3) Let *SV* be *V* with effective data type *SDT*, as represented by the length value *L* and by the values of the *TYPE*, *PRECISION*, and *SCALE* fields.

g) Let *TDT* be the effective data type of the *i*-th parameter as represented by the values of the *TYPE*, *LENGTH*, *PRECISION*, *SCALE*, *DATETIME_INTERVAL_CODE*, *DATETIME_INTERVAL_PRECISION*, *CHARACTER_SET_CATALOG*, *CHARACTER_SET_SCHEMA*, *CHARACTER_SET_NAME*, *USER_DEFINED_TYPE_CATALOG*, *USER_DEFINED_TYPE_SCHEMA*, *USER_DEFINED_TYPE_NAME*, *SCOPE_CATALOG*, *SCOPE_SCHEMA*, and *SCOPE_NAME* fields in the *i*-th item descriptor area of *WPD* for which the *LEVEL* value is 0 (zero), and all its subordinate descriptor areas.

h) If *SDT* is an array locator data type or multiset locator data type, then let *TV* be the value *SV*.

i) If *SDT* and *TDT* are predefined data types, then

Case:

i) If *SDT* and *TDT* are binary string types, then the <cast specification>

`CAST (SV AS TDT)`

is effectively performed and the result is the value *TV* of the *i*-th parameter.

ii) If *SDT* and *TDT* are numeric data types, then the <cast specification>

21.5 Implicit EXECUTE USING and OPEN USING clauses

CAST (*SV AS TDT*)

is effectively performed and the result is the value *TV* of the *i*-th parameter.

- iii) Otherwise, the <cast specification>

CAST (*SV AS TDT*)

is effectively performed and the result is the value *TV* of the *i*-th parameter.

Conformance Rules

None.

21.6 Implicit FETCH USING clause

Function

Specify the rules for an implicit FETCH USING clause.

General Rules

- 1) Let *OE* be an *OPENED FDW-EXECUTION* specified in the rules of this Subclause.
- 2) Let *HL1* be the standard host language in which the SQL-server is written and let *HL2* be the standard host language in which the foreign-data wrapper is written.
- 3) Case:
 - a) If the PASSTHROUGH flag associated with *OE* is *True*, then let *RD* be the wrapper row descriptor associated with *OE*.
 - b) Otherwise, let *RD* be the table reference descriptor associated with *OE*.
- 4) Let *SRD* be the server row descriptor associated with *OE*.
- 5) *RD* and *SRD* describe the <select list> columns and <target specification>s, respectively, for the column values that are to be retrieved.
 - a) Let *AD* be the value of the COUNT field of *SRD*. If *AD* is less than zero, then an exception condition is raised: *dynamic SQL error — invalid descriptor count*.
 - b) Case:
 - i) If *HL1* and *HL2* are both pointer-supporting languages, then for each item descriptor area in *SRD* whose LEVEL is 0 (zero) in the first *AD* item descriptor areas of *SRD*, and for all of their subordinate descriptor areas, refer to a <target specification> whose corresponding item descriptor areas have a non-zero DATA_POINTER as a *bound target* and refer to the corresponding <select list> column as a *bound column*.
 - ii) Otherwise, for each item descriptor area in *SRD* whose LEVEL is 0 (zero) in the first *AD* item descriptor areas of *SRD*, and for all of their subordinate descriptor areas, refer to a <target specification> as a *bound target* and refer to the corresponding <select list> column as a *bound column*.
 - c) If any item descriptor area corresponding to a bound target in the first *AD* item descriptor areas of *SRD* is not valid as specified in Subclause 21.1, “Description of foreign-data wrapper item descriptor areas”, then an exception condition is raised: *dynamic SQL error — using clause does not match target specifications*.
 - d) Let *SDT* be the effective data type of the *i*-th bound column as represented by the values of the TYPE, LENGTH, PRECISION, SCALE, DATETIME_INTERVAL_CODE, DATETIME_INTERVAL_PRECISION, CHARACTER_SET_CATALOG, CHARACTER_SET_SCHEMA, CHARACTER_SET_NAME, USER_DEFINED_TYPE_CATALOG, USER_DEFINED_TYPE_SCHEMA, USER_DEFINED_TYPE_NAME, SCOPE_CATALOG, SCOPE_SCHEMA, and SCOPE_NAME fields in the *i*-th item descriptor area of *RD* whose LEVEL is 0 (zero) and all of its subordinate descriptor areas.

- e) Let *TYPE*, *OL*, *D*, *DP*, *IP*, and *LP* be the values of the TYPE, OCTET_LENGTH, DATA, DATA_POINTER, INDICATOR, and OCTET_LENGTH fields, respectively, in the item descriptor area of *SRD* corresponding to the *i*-th bound target (or part thereof, if the item descriptor area is a subordinate descriptor).
- f) Let *SV* be the value of the <select list> column, with data type *SDT*.
- g) Case:
- i) If *TYPE* indicates CHARACTER, then:
- 1) Let *UT* be the code value corresponding to CHARACTER VARYING as specified in Table 6, “Codes used for implementation data types in SQL/CLI”, in ISO/IEC 9075-3.
 - 2) Let *LV* be the implementation-defined maximum length for a CHARACTER VARYING data type.
- ii) Otherwise, let *UT* be *TYPE* and let *LV* be 0 (zero).
- h) Let *TDT* be the effective data type of the *i*-th bound target as represented by the type *UT*, the length value *LV*, and the values of the PRECISION, SCALE, CHARACTER_SET_CATALOG, CHARACTER_SET_SCHEMA, CHARACTER_SET_NAME, USER_DEFINED_TYPE_CATALOG, USER_DEFINED_TYPE_SCHEMA, USER_DEFINED_TYPE_NAME, SCOPE_CATALOG, SCOPE_SCHEMA, and SCOPE_NAME fields in the item descriptor area of *SRD* whose LEVEL is 0 (zero) and all of its subordinate descriptor areas.
- i) If *TDT* is an array locator data type or a multiset locator data type, then
- Case:
- i) If *SV* is not the null value, then a locator *L* that uniquely identifies *SV* is generated and the value *TV* of the *i*-th bound target is set to an implementation-dependent four-octet value that represents *L*.
- ii) Otherwise, the value *TV* of the *i*-th bound target is the null value.
- j) If *SDT* and *TDT* are predefined data types, then
- Case:
- i) If *SDT* and *TDT* are binary string types, then the <cast specification>
- ```
CAST (SV AS TDT)
```
- is effectively performed and the result is the value *TV* of the *i*-th parameter.
- ii) If *SDT* and *TDT* are numeric data types, then the <cast specification>
- ```
CAST ( SV AS TDT )
```
- is effectively performed and the result is the value *TV* of the *i*-th parameter.
- iii) Otherwise, the <transcoding>
- ```
CONVERT (CAST (SV AS CHARACTER VARYING (M)) USING UTF16)
```
- is effectively performed, where *M* is the implementation-defined maximum length of a variable-length character string, and the result is the value *TV* of the *i*-th parameter.

- k) Let *IDA* be the top-level item descriptor area corresponding to the *i*-th bound column.
- l) Case:
  - i) If TYPE indicates ROW, then
    - Case:
      - 1) If *TV* is the null value, then the value of *IP* for *IDA* and that in all subordinate descriptor areas of *IDA* that are not subordinate to an item descriptor area whose TYPE indicates ARRAY, ARRAY LOCATOR, MULTISSET, or MULTISSET LOCATOR, is set to the appropriate 'Code' for SQL NULL DATA in Table 26, “Miscellaneous codes used in CLI”, in ISO/IEC 9075-3, and the value of the host variable addressed by *DP* and the values of *D* and *LP* are implementation-dependent.
      - 2) Otherwise, the *i*-th subordinate descriptor area of *IDA* is set to reflect the value of the *i*-th field of *TV* by applying General Rule 5)l) to the *i*-th subordinate descriptor area of *IDA* as *IDA*, the value of *i*-th field of *TV* as *TV*, the value of the *i*-th field of *SV* as *SV*, and the data type of the *i*-th field of *SV* as *SDT*.
    - ii) Otherwise,
      - Case:
        - 1) If *TV* is the null value, then the value of *IP* is set to the appropriate 'Code' for SQL NULL DATA in Table 26, “Miscellaneous codes used in CLI”, in ISO/IEC 9075-3, and the value of the host variable addressed by *DP* and the value of *D* and the value of *LP* are implementation-dependent.
        - 2) Otherwise:
          - A) The value of *IP* is set to 0 (zero).
          - B) Case:
            - I) If TYPE indicates CHARACTER or CHARACTER LARGE OBJECT, then:
              - 1) If *TV* is a zero-length character string, then it is implementation-defined whether or not an exception condition is raised: *data exception — zero-length character string*.
              - 2) Case:
                - a) If *HL1* and *HL2* are both pointer-supporting languages, then the General Rules of Subclause 21.7, “Character string retrieval”, are applied with *DP*, *TV*, *OL*, and *LP* as *TARGET*, *VALUE*, *TARGET OCTET LENGTH*, and *RETURNED OCTET LENGTH*, respectively.
                - b) Otherwise, the General Rules of Subclause 21.7, “Character string retrieval”, are applied with *D*, *TV*, *OL*, and *LP*, as *TARGET*, *VALUE*, *TARGET OCTET LENGTH*, and *RETURNED OCTET LENGTH*, respectively.
            - II) If TYPE indicates BINARY LARGE OBJECT, then
              - Case:

- 1) If *HL1* and *HL2* are both pointer-supporting languages, then the General Rules of Subclause 21.8, “Binary large object string retrieval”, are applied with *DP*, *TV*, *OL*, and *LP* as *TARGET*, *VALUE*, *TARGET OCTET LENGTH*, and *RETURNED OCTET LENGTH*, respectively.
  - 2) Otherwise, the General Rules of Subclause 21.8, “Binary large object string retrieval”, are applied with *D*, *TV*, *OL*, and *LP* as *TARGET*, *VALUE*, *TARGET OCTET LENGTH*, and *RETURNED OCTET LENGTH*, respectively.
- III) If TYPE indicates ARRAY, ARRAY LOCATOR, MULTISSET, or MULTISSET LOCATOR, then the value of RETURNED\_CARDINALITY is set to the cardinality of *TV*.
- IV) Otherwise,
- Case:
- 1) If *HL1* and *HL2* are both pointer-supporting languages, then the value of the host variable addressed by *DP* is set to *TV* and the value of *LP* is implementation-dependent.
  - 2) Otherwise, the value of *D* is set to *TV* and the value of *LP* is implementation-dependent.

## Conformance Rules

*None.*

## 21.7 Character string retrieval

### Function

Specify the rules for retrieving character string values.

### General Rules

- 1) Let  $T$ ,  $V$ ,  $TL$ , and  $RL$  be a *TARGET*, *VALUE*, *TARGET OCTET LENGTH*, and *RETURNED OCTET LENGTH* specified in an application of this Subclause.
- 2) If  $TL$  is not greater than zero, then an exception condition is raised: *FDW-specific condition — invalid string length or buffer length*.
- 3) Let  $L$  be the length in octets of  $V$ .
- 4) If  $RL$  is not a null pointer, then  $RL$  is set to  $L$ .
- 5) Case:
  - a) If  $L$  is not greater than  $TL$ , then the first  $L$  octets of  $T$  are set to  $V$  and the values of the remaining octets of  $T$  are implementation-dependent.
  - b) Otherwise,  $T$  is set to the first  $TL$  octets of  $V$  and a completion condition is raised: *warning — string data, right truncation*.

### Conformance Rules

*None.*

## 21.8 Binary large object string retrieval

### Function

Specify the rules for retrieving BINARY LARGE OBJECT string values.

### General Rules

- 1) Let  $T$ ,  $V$ ,  $TL$ , and  $RL$  be a *TARGET*, *VALUE*, *TARGET OCTET LENGTH*, and *RETURNED OCTET LENGTH* specified in an application of this Subclause.
- 2) If  $TL$  is not greater than zero, then an exception condition is raised: *FDW-specific condition — invalid string length or buffer length*.
- 3) Let  $L$  be the length in octets of  $V$ .
- 4) If  $RL$  is not a null pointer, then  $RL$  is set to  $L$ .
- 5) Case:
  - a) If  $L$  is not greater than  $TL$ , then the first  $L$  octets of  $T$  are set to  $V$  and the values of the remaining octets of  $T$  are implementation-dependent.
  - b) Otherwise,  $T$  is set to the first  $TL$  octets of  $V$  and a completion condition is raised: *warning — string data, right truncation*.

### Conformance Rules

*None.*

## 21.9 Tables used with SQL/MED

The tables contained in this Subclause are used to specify the codes used by the various foreign-data wrapper interface routines.

**Table 27 — Codes used for <table reference> types**

| <table reference> type | Code |
|------------------------|------|
| TABLE_NAME             | 1    |

**Table 28 — Codes used for <value expression> kinds**

| <value expression> kind | Code |
|-------------------------|------|
| COLUMN_NAME             | 1    |
| CONSTANT                | 2    |
| OPERATOR                | 3    |
| PARAMETER               | 4    |

**Table 29 — Codes used for foreign-data wrapper diagnostic fields**

| Field                | Code | Type   |
|----------------------|------|--------|
| CLASS_ORIGIN         | 1    | Status |
| MESSAGE_LENGTH       | 2    | Status |
| MESSAGE_OCTET_LENGTH | 3    | Status |
| MESSAGE_TEXT         | 4    | Status |
| MORE                 | 5    | Header |
| NATIVE_CODE          | 6    | Status |
| NUMBER               | 7    | Header |
| RETURNCODE           | 8    | Header |
| SQLSTATE             | 9    | Status |
| SUBCLASS_ORIGIN      | 10   | Status |

| Field                                           | Code | Type   |
|-------------------------------------------------|------|--------|
| Implementation-defined diagnostics header field | < 0  | Header |
| Implementation-defined diagnostics status field | < 0  | Status |

**Table 30 — Codes used for foreign-data wrapper descriptor fields**

| Field                       | Code | SQL Item Descriptor Name    | Type   |
|-----------------------------|------|-----------------------------|--------|
| CARDINALITY                 | 1040 | CARDINALITY                 | Item   |
| CHARACTER_SET_CATALOG       | 1018 | CHARACTER_SET_CATALOG       | Item   |
| CHARACTER_SET_NAME          | 1020 | CHARACTER_SET_NAME          | Item   |
| CHARACTER_SET_SCHEMA        | 1019 | CHARACTER_SET_SCHEMA        | Item   |
| COLLATION_CATALOG           | 1015 | COLLATION_CATALOG           | Item   |
| COLLATION_NAME              | 1017 | COLLATION_NAME              | Item   |
| COLLATION_SCHEMA            | 1016 | COLLATION_SCHEMA            | Item   |
| COUNT                       | 1001 | COUNT                       | Header |
| CURRENT_TRANSFORM_GROUP     | 1039 | (Not applicable)            | Item   |
| DATA                        | 1050 | DATA                        | Item   |
| DATA_POINTER                | 1010 | DATA                        | Item   |
| DATETIME_INTERVAL_CODE      | 1007 | DATETIME_INTERVAL_CODE      | Item   |
| DATETIME_INTERVAL_PRECISION | 26   | DATETIME_INTERVAL_PRECISION | Item   |
| DEGREE                      | 1041 | DEGREE                      | Item   |
| DYNAMIC_FUNCTION            | 1031 | DYNAMIC_FUNCTION            | Header |
| DYNAMIC_FUNCTION_CODE       | 1032 | DYNAMIC_FUNCTION_CODE       | Header |
| INDICATOR                   | 1051 | INDICATOR                   | Item   |
| KEY_MEMBER                  | 1030 | KEY_MEMBER                  | Item   |
| KEY_TYPE                    | 1029 | KEY_TYPE                    | Header |
| LENGTH                      | 1003 | LENGTH                      | Item   |



**CD ISO/IEC 9075-9:2007 (E)**  
**21.9 Tables used with SQL/MED**

| <b>Field</b>               | <b>Code</b> | <b>SQL Item Descriptor Name</b>                              | <b>Type</b> |
|----------------------------|-------------|--------------------------------------------------------------|-------------|
| LEVEL                      | 1042        | LEVEL                                                        | Item        |
| NAME                       | 1011        | NAME                                                         | Item        |
| NULLABLE                   | 1008        | NULLABLE                                                     | Item        |
| OCTET_LENGTH               | 1013        | OCTET_LENGTH                                                 | Item        |
| PARAMETER_MODE             | 1021        | PARAMETER_MODE                                               | Item        |
| PARAMETER_ORDINAL_POSITION | 1022        | PARAMETER_ORDINAL_POSITION                                   | Item        |
| PARAMETER_SPECIFIC_CATALOG | 1023        | PARAMETER_SPECIFIC_CATALOG                                   | Item        |
| PARAMETER_SPECIFIC_NAME    | 1025        | PARAMETER_SPECIFIC_NAME                                      | Item        |
| PARAMETER_SPECIFIC_SCHEMA  | 1024        | PARAMETER_SPECIFIC_SCHEMA                                    | Item        |
| PRECISION                  | 1005        | PRECISION                                                    | Item        |
| RETURNED_CARDINALITY       | 1052        | RETURNED_CARDINALITY                                         | Item        |
| RETURNED_OCTET_LENGTH      | 1053        | Both OCTET_LENGTH (input) and RETURNED_OCTET_LENGTH (output) | Item        |
| SCALE                      | 1006        | SCALE                                                        | Item        |
| SCOPE_CATALOG              | 1033        | SCOPE_CATALOG                                                | Item        |
| SCOPE_NAME                 | 1034        | SCOPE_NAME                                                   | Item        |
| SCOPE_SCHEMA               | 1035        | SCOPE_SCHEMA                                                 | Item        |
| SPECIFIC_TYPE_CATALOG      | 1036        | (Not applicable)                                             | Item        |
| SPECIFIC_TYPE_NAME         | 1038        | (Not applicable)                                             | Item        |
| SPECIFIC_TYPE_SCHEMA       | 1037        | (Not applicable)                                             | Item        |
| TOP_LEVEL_COUNT            | 1044        | TOP_LEVEL_COUNT                                              | Header      |
| TYPE                       | 1002        | TYPE                                                         | Item        |
| UNNAMED                    | 1012        | UNNAMED                                                      | Item        |
| USER_DEFINED_TYPE_CATALOG  | 1026        | USER_DEFINED_TYPE_CATALOG                                    | Item        |
| USER_DEFINED_TYPE_NAME     | 1028        | USER_DEFINED_TYPE_NAME                                       | Item        |
| USER_DEFINED_TYPE_SCHEMA   | 1027        | USER_DEFINED_TYPE_SCHEMA                                     | Item        |

| Field                                                               | Code                                                                          | SQL Item Descriptor Name                                            | Type   |
|---------------------------------------------------------------------|-------------------------------------------------------------------------------|---------------------------------------------------------------------|--------|
| Implementation-defined foreign-data wrapper descriptor header field | 0 (zero) through 999, or $\geq 1200$ , excluding values defined in this table | Implementation-defined foreign-data wrapper descriptor header field | Header |
| Implementation-defined foreign-data wrapper descriptor item field   | 0 (zero) through 999, or $\geq 1200$ , excluding values defined in this table | Implementation-defined foreign-data wrapper descriptor item field   | Item   |

**Table 31 — Codes used for foreign-data wrapper handle types**

| Handle type           | Code |
|-----------------------|------|
| ExecutionHandle       | 1    |
| FSConnectionHandle    | 2    |
| ReplyHandle           | 3    |
| RequestHandle         | 4    |
| ServerHandle          | 6    |
| TableReferenceHandle  | 7    |
| UserHandle            | 8    |
| ValueExpressionHandle | 9    |
| WrapperHandle         | 10   |
| WrapperEnvHandle      | 11   |
| DescriptorHandle      | 12   |

Table 32 — Ability to retrieve foreign-data wrapper descriptor fields

| Field                       | May be retrieved |            |     |     |
|-----------------------------|------------------|------------|-----|-----|
|                             | SRD              | WRD or TRD | SPD | WPD |
| CARDINALITY                 | No               |            | No  |     |
| CHARACTER_SET_CATALOG       |                  |            |     |     |
| CHARACTER_SET_NAME          |                  |            |     |     |
| CHARACTER_SET_SCHEMA        |                  |            |     |     |
| COLLATION_CATALOG           |                  |            |     |     |
| COLLATION_NAME              |                  |            |     |     |
| COLLATION_SCHEMA            |                  |            |     |     |
| COUNT                       |                  |            |     |     |
| CURRENT_TRANSFORM_GROUP     |                  |            |     |     |
| DATA                        |                  | No         |     | No  |
| DATA_POINTER                |                  | No         |     | No  |
| DATETIME_INTERVAL_CODE      |                  |            |     |     |
| DATETIME_INTERVAL_PRECISION |                  |            |     |     |
| DEGREE                      | No               |            | No  |     |
| DYNAMIC_FUNCTION            | No               |            | No  |     |
| DYNAMIC_FUNCTION_CODE       | No               |            | No  |     |
| INDICATOR                   |                  | No         |     | No  |
| KEY_MEMBER                  | No               |            | No  | No  |
| KEY_TYPE                    | No               |            | No  | No  |
| LENGTH                      |                  |            |     |     |
| LEVEL                       |                  |            |     |     |
| NAME                        |                  |            |     |     |
| NULLABLE                    |                  |            |     |     |

|                                                                     | May be retrieved |            |     |     |
|---------------------------------------------------------------------|------------------|------------|-----|-----|
| Field                                                               | SRD              | WRD or TRD | SPD | WPD |
| OCTET_LENGTH                                                        |                  |            |     |     |
| PARAMETER_MODE                                                      | No               |            | No  |     |
| PARAMETER_ORDINAL_POSITION                                          | No               |            | No  |     |
| PARAMETER_SPECIFIC_CATALOG                                          | No               |            | No  |     |
| PARAMETER_SPECIFIC_NAME                                             | No               |            | No  |     |
| PARAMETER_SPECIFIC_SCHEMA                                           | No               |            | No  |     |
| PRECISION                                                           |                  |            |     |     |
| RETURNED_CARDINALITY                                                |                  | No         |     | No  |
| RETURNED_OCTET_LENGTH                                               |                  | No         |     | No  |
| SCALE                                                               |                  |            |     |     |
| SCOPE_CATALOG                                                       |                  |            |     |     |
| SCOPE_NAME                                                          |                  |            |     |     |
| SCOPE_SCHEMA                                                        |                  |            |     |     |
| SPECIFIC_TYPE_CATALOG                                               |                  |            |     |     |
| SPECIFIC_TYPE_NAME                                                  |                  |            |     |     |
| SPECIFIC_TYPE_SCHEMA                                                |                  |            |     |     |
| TOP_LEVEL_COUNT                                                     |                  |            |     |     |
| TYPE                                                                |                  |            |     |     |
| UNNAMED                                                             |                  |            |     |     |
| USER_DEFINED_TYPE_CATALOG                                           |                  |            |     |     |
| USER_DEFINED_TYPE_NAME                                              |                  |            |     |     |
| USER_DEFINED_TYPE_SCHEMA                                            |                  |            |     |     |
| Implementation-defined foreign-data wrapper descriptor header field | ID               | ID         | ID  | ID  |

|                                                                                                                                                                                                                                                                                                                                                                                                       | May be retrieved |            |     |     |
|-------------------------------------------------------------------------------------------------------------------------------------------------------------------------------------------------------------------------------------------------------------------------------------------------------------------------------------------------------------------------------------------------------|------------------|------------|-----|-----|
| Field                                                                                                                                                                                                                                                                                                                                                                                                 | SRD              | WRD or TRD | SPD | WPD |
| Implementation-defined foreign-data wrapper descriptor item field                                                                                                                                                                                                                                                                                                                                     | ID               | ID         | ID  | ID  |
| † <b>Where</b> “No” means that the descriptor field is not retrievable, <i>PS</i> means that the descriptor field is retrievable from the IRD only when a prepared or executed statement is associated with the IRD, the absence of any notation means that the descriptor field is retrievable, and “ID” means that it is implementation-defined whether or not the descriptor field is retrievable. |                  |            |     |     |

**Table 33 — Ability to set foreign-data wrapper descriptor fields**

|                             | May be set |            |     |     |
|-----------------------------|------------|------------|-----|-----|
| Field                       | SRD        | WRD or TRD | SPD | WPD |
| CARDINALITY                 | No         | No         | No  |     |
| CHARACTER_SET_CATALOG       |            | No         |     |     |
| CHARACTER_SET_NAME          |            | No         |     |     |
| CHARACTER_SET_SCHEMA        |            | No         |     |     |
| COLLATION_CATALOG           |            | No         |     |     |
| COLLATION_NAME              |            | No         |     |     |
| COLLATION_SCHEMA            |            | No         |     |     |
| COUNT                       |            | No         |     |     |
| CURRENT_TRANSFORM_GROUP     | No         | No         | No  | No  |
| DATA                        |            | No         |     |     |
| DATA_POINTER                |            | No         |     |     |
| DATETIME_INTERVAL_CODE      |            | No         |     |     |
| DATETIME_INTERVAL_PRECISION |            | No         |     |     |
| DEGREE                      | No         | No         | No  |     |
| DYNAMIC_FUNCTION            | No         | No         | No  | No  |
| DYNAMIC_FUNCTION_CODE       | No         | No         | No  | No  |
| INDICATOR                   |            | No         |     | No  |

|                            | May be set |            |     |     |
|----------------------------|------------|------------|-----|-----|
| Field                      | SRD        | WRD or TRD | SPD | WPD |
| KEY_MEMBER                 | No         | No         | No  | No  |
| KEY_TYPE                   | No         | No         | No  | No  |
| LENGTH                     |            | No         |     |     |
| LEVEL                      |            | No         |     |     |
| NAME                       |            | No         |     |     |
| NULLABLE                   |            | No         |     |     |
| OCTET_LENGTH               |            | No         |     |     |
| PARAMETER_MODE             | No         | No         | No  |     |
| PARAMETER_ORDINAL_POSITION | No         | No         | No  |     |
| PARAMETER_SPECIFIC_CATALOG | No         | No         | No  |     |
| PARAMETER_SPECIFIC_NAME    | No         | No         | No  |     |
| PARAMETER_SPECIFIC_SCHEMA  | No         | No         | No  |     |
| PRECISION                  |            | No         |     |     |
| RETURNED_CARDINALITY       |            | No         |     | No  |
| RETURNED_OCTET_LENGTH      |            | No         |     | No  |
| SCALE                      |            | No         |     |     |
| SCOPE_CATALOG              |            | No         |     |     |
| SCOPE_NAME                 |            | No         |     |     |
| SCOPE_SCHEMA               |            | No         |     |     |
| SPECIFIC_TYPE_CATALOG      | No         | No         | No  | No  |
| SPECIFIC_TYPE_NAME         | No         | No         | No  | No  |
| SPECIFIC_TYPE_SCHEMA       | No         | No         | No  | No  |
| TOP_LEVEL_COUNT            |            | No         |     |     |
| TYPE                       |            | No         |     |     |

|                                                                     | May be set |            |     |     |
|---------------------------------------------------------------------|------------|------------|-----|-----|
| Field                                                               | SRD        | WRD or TRD | SPD | WPD |
| UNNAMED                                                             |            | No         |     |     |
| USER_DEFINED_TYPE_CATALOG                                           |            | No         |     |     |
| USER_DEFINED_TYPE_NAME                                              |            | No         |     |     |
| USER_DEFINED_TYPE_SCHEMA                                            |            | No         |     |     |
| Implementation-defined foreign-data wrapper descriptor header field | ID         | ID         | ID  | ID  |
| Implementation-defined foreign-data wrapper descriptor item field   | ID         | ID         | ID  | ID  |

† **Where** “No” means that the descriptor field is not settable, “ID” means that it is implementation-defined whether or not the descriptor field is settable, and the absence of any notation means that the descriptor field is settable.

**Table 34 — Foreign-data wrapper descriptor field default values**

|                         | Default values |            |          |     |
|-------------------------|----------------|------------|----------|-----|
| Field                   | SRD            | WRD or TRD | APD      | WPD |
| CARDINALITY             |                |            |          |     |
| CHARACTER_SET_CATALOG   |                |            |          |     |
| CHARACTER_SET_NAME      |                |            |          |     |
| CHARACTER_SET_SCHEMA    |                |            |          |     |
| COLLATION_CATALOG       |                |            |          |     |
| COLLATION_NAME          |                |            |          |     |
| COLLATION_SCHEMA        |                |            |          |     |
| COUNT                   | 0 (zero)       |            | 0 (zero) |     |
| CURRENT_TRANSFORM_GROUP |                |            |          |     |
| DATA                    |                |            |          |     |
| DATA_POINTER            | Null           |            | Null     |     |
| DATETIME_INTERVAL_CODE  |                |            |          |     |

| Field                       | Default values |            |     |     |
|-----------------------------|----------------|------------|-----|-----|
|                             | SRD            | WRD or TRD | APD | WPD |
| DATETIME_INTERVAL_PRECISION |                |            |     |     |
| DEGREE                      |                |            |     |     |
| DYNAMIC_FUNCTION            |                |            |     |     |
| DYNAMIC_FUNCTION_CODE       |                |            |     |     |
| INDICATOR                   |                |            |     |     |
| KEY_MEMBER                  |                |            |     |     |
| KEY_TYPE                    |                |            |     |     |
| LENGTH                      |                |            |     |     |
| LEVEL                       | 0 (zero)       |            |     |     |
| NAME                        |                |            |     |     |
| NULLABLE                    |                |            |     |     |
| OCTET_LENGTH                |                |            |     |     |
| PARAMETER_MODE              |                |            |     |     |
| PARAMETER_ORDINAL_POSITION  |                |            |     |     |
| PARAMETER_SPECIFIC_CATALOG  |                |            |     |     |
| PARAMETER_SPECIFIC_NAME     |                |            |     |     |
| PARAMETER_SPECIFIC_SCHEMA   |                |            |     |     |
| PRECISION                   |                |            |     |     |
| RETURNED_CARDINALITY        |                |            |     |     |
| RETURNED_OCTET_LENGTH       |                |            |     |     |
| SCALE                       |                |            |     |     |
| SCOPE_CATALOG               |                |            |     |     |
| SCOPE_NAME                  |                |            |     |     |
| SCOPE_SCHEMA                |                |            |     |     |



CD ISO/IEC 9075-9:2007 (E)  
 21.9 Tables used with SQL/MED

| Field                                                               | Default values |            |          |     |
|---------------------------------------------------------------------|----------------|------------|----------|-----|
|                                                                     | SRD            | WRD or TRD | APD      | WPD |
| SPECIFIC_TYPE_CATALOG                                               |                |            |          |     |
| SPECIFIC_TYPE_NAME                                                  |                |            |          |     |
| SPECIFIC_TYPE_SCHEMA                                                |                |            |          |     |
| TOP_LEVEL_COUNT                                                     | 0 (zero)       |            | 0 (zero) |     |
| TYPE                                                                |                |            |          |     |
| UNNAMED                                                             |                |            |          |     |
| USER_DEFINED_TYPE_CATALOG                                           |                |            |          |     |
| USER_DEFINED_TYPE_NAME                                              |                |            |          |     |
| USER_DEFINED_TYPE_SCHEMA                                            |                |            |          |     |
| Implementation-defined foreign-data wrapper descriptor header field | ID             | ID         | ID       | ID  |
| Implementation-defined foreign-data wrapper descriptor item field   | ID             | ID         | ID       | ID  |

† **Where** “Null” means that the descriptor field’s default value is a null pointer, the absence of any notation means that the descriptor field’s default value is initially undefined, “ID” means that the descriptor field’s default value is implementation-defined, and any other value specifies the descriptor field’s default value.

**Table 35 — Codes used for the format of the character string transmitted by GetSQLString()**

| Format                         | Code  |
|--------------------------------|-------|
| SQL-string format              | 1     |
| Implementation-defined formats | $x^1$ |

<sup>1</sup> An implementation-defined negative number different from the value associated with any other format.

## 22 Foreign-data wrapper interface routines

### 22.1 <foreign-data wrapper interface routine>

#### Function

Describe a generic foreign-data wrapper interface routine.

#### Format

```

<foreign-data wrapper interface routine> ::=
<foreign-data wrapper interface routine prefix>
<foreign-data wrapper interface routine generic>

<foreign-data wrapper interface routine prefix> ::= MED

<foreign-data wrapper interface routine generic> ::=
<foreign-data wrapper interface routine name>
<foreign-data wrapper parameter list>
[<foreign-data wrapper returns clause>]

<foreign-data wrapper interface routine name> ::=
AdvanceInitRequest
| AllocDescriptor
| AllocQueryContext
| AllocWrapperEnv
| Close
| ConnectServer
| FreeDescriptor
| FreeExecutionHandle
| FreeFSConnection
| FreeQueryContext
| FreeReplyHandle
| FreeWrapperEnv
| GetAuthorizationId
| GetBoolVE
| GetDescriptor
| GetDiagnostics
| GetDistinct
| GetNextReply
| GetNumBoolVE
| GetNumChildren
| GetNumOrderByElems
| GetNumReplyBoolVE
| GetNumReplyOrderBy
| GetNumReplySelectElems
| GetNumReplyTableRefs
| GetNumRoutMapOpts

```

## CD ISO/IEC 9075-9:2007 (E)

### 22.1 <foreign-data wrapper interface routine>

- | GetNumSelectElems
- | GetNumServerOpts
- | GetNumTableColOpts
- | GetNumTableOpts
- | GetNumTableRefElems
- | GetNumUserOpts
- | GetNumWrapperOpts
- | GetOpts
- | GetOrderByElem
- | GetReplyBoolVE
- | GetReplyCardinality
- | GetReplyDistinct
- | GetReplyExecCost
- | GetReplyFirstCost
- | GetReplyOrderElem
- | GetReplyReExecCost
- | GetReplySelectElem
- | GetReplyTableRef
- | GetRoutineMapping
- | GetRoutMapOpt
- | GetRoutMapOptName
- | GetSelectElem
- | GetSelectElemType
- | GetServerName
- | GetServerOpt
- | GetServerOptByName
- | GetServerType
- | GetServerVersion
- | GetSPDHandle
- | GetSQLString
- | GetSRDHandle
- | GetStatistics
- | GetTableColOpt
- | GetTableColOptByName
- | GetTableOpt
- | GetTableOptByName
- | GetTableRefElem
- | GetTableRefElemType
- | GetTableRefTableName
- | GetTableServerName
- | GetTRDHandle
- | GetUserOpt
- | GetUserOptByName
- | GetValExprColName
- | GetValueExpDesc
- | GetValueExpKind
- | GetValueExpName
- | GetValueExpTable
- | GetVEChild
- | GetWPDHandle
- | GetWrapperLibraryName
- | GetWrapperName
- | GetWrapperOpt
- | GetWrapperOptByName
- | GetWRDHandle
- | InitRequest
- | Iterate

```

| Open
| ReOpen
| SetDescriptor
| TransmitRequest

<foreign-data wrapper parameter list> ::=
<left paren> <foreign-data wrapper parameter declaration>
[{ <comma> <foreign-data wrapper parameter declaration> }...] <right paren>

<foreign-data wrapper parameter declaration> ::=
<foreign-data wrapper parameter name>
<foreign-data wrapper parameter mode>
<foreign-data wrapper parameter data type>

<foreign-data wrapper parameter name> ::=
!! See the individual foreign-data wrapper interface routine definitions

<foreign-data wrapper parameter mode> ::=
IN
| OUT
| INOUT

<foreign-data wrapper parameter data type> ::=
INTEGER
| SMALLINT
| ANY
| CHARACTER <left paren> <length> <right paren>

<foreign-data wrapper returns clause> ::= RETURNS SMALLINT

```

## Syntax Rules

- 1) A <foreign-data wrapper interface routine> defines a predefined routine written in a standard programming language that is invoked by a compilation unit of the same standard programming language. Let *HL* be that standard programming language. *HL* shall be one of Ada, C, COBOL, Fortran, M, Pascal, or PL/I.
- 2) A <foreign-data wrapper interface routine> that contains a <foreign-data wrapper returns clause> is called a *foreign-data wrapper interface function*. A <foreign-data wrapper interface routine> that does not contain a <foreign-data wrapper returns clause> is called a *foreign-data wrapper interface procedure*.
- 3) For each foreign-data wrapper interface function *WF*, there is a corresponding foreign-data wrapper interface procedure *WP*, with the same <foreign-data wrapper interface routine name>. The <foreign-data wrapper parameter list> for *WP* is the same as the <foreign-data wrapper parameter list> for *WF* but with the following additional <foreign-data wrapper parameter declaration>:

```
ReturnCode OUT SMALLINT
```

- 4) *HL* shall support either the invocation of *WF* or the invocation of *WP*. It is implementation-defined which is supported.
- 5) Case:
  - a) If <foreign-data wrapper parameter mode> is IN, then the parameter is an *input parameter*.
  - b) If <foreign-data wrapper parameter mode> is OUT, then the parameter is an *output parameter*.

22.1 <foreign-data wrapper interface routine>

- c) If <foreign-data wrapper parameter mode> is INOUT, then the parameter is both an input parameter and an output parameter.

NOTE 60 — An output parameter is either a non-pointer host variable passed by reference or a pointer host variable passed by value.

- 6) There shall be no <separator> between the <foreign-data wrapper interface routine prefix> and the <foreign-data wrapper interface routine generic> in a <foreign-data wrapper interface routine name>.
- 7) Let *WR* be a <foreign-data wrapper interface routine> and let *RN* be its <foreign-data wrapper interface routine name>. Let *RNU* be the value of UPPER (*RN*).

Case:

- a) If *HL* supports case sensitive routine names, then the name used for the invocation of *WR* shall be *RN*.
  - b) If *HL* does not support <simple Latin lower case letter>s, then the name used for the invocation of *WR* shall be *RNU*.
  - c) If *HL* does not support case sensitive routine names, then the name used for the invocation of *WR* shall be *RN* or *RNU*.
- 8) Let *operative data type correspondence table* be the data type correspondence table for *HL* as specified in Subclause 19.5, “SQL/CLI data type correspondences”. Refer to the two columns of the operative data type correspondence table as the “SQL data type column” and the “host data type column”.
  - 9) Let *TI*, *TS*, *TC*, and *TV* be the types listed in the host data type column for the rows that contains INTEGER, SMALLINT, CHARACTER(L) and CHARACTER VARYING(L), respectively, in the SQL data type column.
- a) If *TS* is “None”, then let *TS* = *TI*.
  - b) If *TC* is “None”, then let *TC* = *TV*.
  - c) For each parameter *P*,

Case:

- i) If the foreign-data wrapper parameter data type is INTEGER, then the type of the corresponding argument shall be *TI*.
- ii) If the foreign-data wrapper parameter data type is SMALLINT, then the type of the corresponding argument shall be *TS*.
- iii) If the foreign-data wrapper parameter data type is CHARACTER(L), then the type of the corresponding argument shall be *TC*.
- iv) If the foreign-data wrapper parameter data type is ANY, then

Case:

- 1) If *HL* is C, then the type of the corresponding argument shall be "void \*".
  - 2) Otherwise, the type of the corresponding argument shall be any type (other than 'None') listed in the host data type column.
- d) If the foreign-data wrapper interface routine is a foreign-data wrapper interface function, then the type of the returned value is *TS*.

## Access Rules

*None.*

## General Rules

- 1) The rules for invocation of the <foreign-data wrapper interface routine> are specified in Subclause 22.2, “<foreign-data wrapper interface routine> invocation”.

## Conformance Rules

- 1) Without Feature M018, “Foreign-data wrapper interface routines in Ada”, a conforming foreign-data wrapper shall not contain an invocation of a <foreign-data wrapper interface routine> written in Ada.
- 2) Without Feature M019, “Foreign-data wrapper interface routines in C”, a conforming foreign-data wrapper shall not contain an invocation of a <foreign-data wrapper interface routine> written in C.
- 3) Without Feature M020, “Foreign-data wrapper interface routines in COBOL”, a conforming foreign-data wrapper shall not contain an invocation of a <foreign-data wrapper interface routine> written in COBOL.
- 4) Without Feature M021, “Foreign-data wrapper interface routines in Fortran”, a conforming foreign-data wrapper shall not contain an invocation of a <foreign-data wrapper interface routine> written in Fortran.
- 5) Without Feature M022, “Foreign-data wrapper interface routines in MUMPS”, a conforming foreign-data wrapper shall not contain an invocation of a <foreign-data wrapper interface routine> written in M.
- 6) Without Feature M023, “Foreign-data wrapper interface routines in Pascal”, a conforming foreign-data wrapper shall not contain an invocation of a <foreign-data wrapper interface routine> written in Pascal.
- 7) Without Feature M024, “Foreign-data wrapper interface routines in PL/I”, a conforming foreign-data wrapper shall not contain an invocation of a <foreign-data wrapper interface routine> written in PL/I.
- 8) Without Feature M018, “Foreign-data wrapper interface routines in Ada”, a conforming SQLserver shall not contain an invocation of a <foreign-data wrapper interface routine> written in Ada.
- 9) Without Feature M019, “Foreign-data wrapper interface routines in C”, a conforming SQLserver shall not contain an invocation of a <foreign-data wrapper interface routine> written in C.
- 10) Without Feature M020, “Foreign-data wrapper interface routines in COBOL”, a conforming SQL-server shall not contain an invocation of a <foreign-data wrapper interface routine> written in COBOL.
- 11) Without Feature M021, “Foreign-data wrapper interface routines in Fortran”, a conforming SQL-server shall not contain an invocation of a <foreign-data wrapper interface routine> written in Fortran.
- 12) Without Feature M022, “Foreign-data wrapper interface routines in MUMPS”, a conforming SQL-server shall not contain an invocation of a <foreign-data wrapper interface routine> written in M.
- 13) Without Feature M023, “Foreign-data wrapper interface routines in Pascal”, a conforming SQL-server shall not contain an invocation of a <foreign-data wrapper interface routine> written in Pascal.
- 14) Without Feature M024, “Foreign-data wrapper interface routines in PL/I”, a conforming SQLserver shall not contain an invocation of a <foreign-data wrapper interface routine> written in PL/I.

## 22.2 <foreign-data wrapper interface routine> invocation

### Function

Specify the rules for invocation of a <foreign-data wrapper interface routine>.

### Syntax Rules

- 1) Let *HL* be the standard programming language of *CP*, the caller of a <foreign-data wrapper interface routine>.
- 2) A foreign-data wrapper interface function or foreign-data wrapper interface procedure is invoked by the *HL* mechanism for invoking functions or procedures, respectively.
- 3) Let *RN* be the <foreign-data wrapper interface routine name> of the <foreign-data wrapper interface routine> invoked by *CP*. The number of arguments provided in the invocation shall be the same as the number of <foreign-data wrapper parameter declaration>s for *RN*.
- 4) Let *DA* be the data type of the *i*-th argument in the invocation and let *DP* be the <foreign-data wrapper parameter data type> of the *i*-th <foreign-data wrapper parameter declaration> of *RN*. *DA* shall be the *HL* equivalent of *DP* as specified by the rules of [Subclause 22.1](#), “<foreign-data wrapper interface routine>”.
- 5) Each argument to a <foreign-data wrapper interface routine> that is of type CHARACTER(*n*) shall be passed by reference, according to the mechanisms of *HL*.

Case:

- a) Of *HL* is C, then each input argument to a <foreign-data wrapper interface routine> that is not of type CHARACTER(*n*) shall be passed by value. Each output argument to a <foreign-data wrapper interface routine> that is not of type CHARACTER(*n*) that identifies a non-pointer host variable shall be passed by reference; each output argument to a <foreign-data wrapper interface routine> that is not of type CHARACTER(*n*) that identifies a pointer host variable shall be passed by value.
- b) Otherwise, each input or output argument to a <foreign-data wrapper interface routine> that is not of type CHARACTER(*n*) shall be passed by reference.

### Access Rules

*None.*

### General Rules

- 1) If the value of any input argument provided by *CP* falls outside the set of allowed values of the data type of the parameter, or if the value of any output argument resulting from the execution of the <foreign-data wrapper interface routine> falls outside the set of values supported by *CP* for that parameter, then the effect is implementation-defined.
- 2) When the <foreign-data wrapper interface routine> is called by *CP*:
  - a) The values of all input arguments to *RN* are established.
  - b) *RN* is invoked.

- 3) Case:
- a) If the <foreign-data wrapper interface routine> is a foreign-data wrapper interface function, then:
    - i) The values of all output arguments are established.
    - ii) Let *RC* be the return value.
  - b) If the <foreign-data wrapper interface routine> is a foreign-data wrapper interface procedure, then:
    - i) The values of all output arguments are established except for the argument associated with the *ReturnCode* parameter.
    - ii) Let *RC* be the argument associated with the *ReturnCode* parameter.
- 4) Case:
- a) If *RN* executed successfully, then:
    - i) Either a completion condition is raised: *successful completion*, or a completion condition is raised: *no data*.
    - ii) Case:
      - 1) If a completion condition is raised: *successful completion*, then *RC* is set to indicate **Success**.
      - 2) If a completion condition is raised: *warning*, then *RC* is set to indicate **Success with information**.
      - 3) If a completion condition is raised: *no data*, then *RC* is set to indicate **No data found**.
  - b) If *RN* did not execute successfully, then:
    - i) All changes made to SQL-data or schemas by the execution of *RN* are canceled.
    - ii) One or more exception conditions are raised as determined by the General Rules of this and other Subclauses of this part of ISO/IEC 9075 or by implementation-defined rules.
    - iii) Case:
      - 1) If an exception condition is raised: *FDW-specific condition — invalid handle*, then *RC* is set to indicate **Invalid handle**.
      - 2) Otherwise, *RC* is set to indicate **Error**.
    - iv) If *RN* is a foreign-data wrapper interface wrapper routine, then the actions of invoking the SQL-server in response to the failed execution of *RN* are implementation-dependent.

## Conformance Rules

*None.*



## 22.3 Foreign-data wrapper interface wrapper routines

### 22.3.1 AdvanceInitRequest

#### Function

Determine whether a foreign-data wrapper can execute a foreign server request and gather multiple different FDW-replies and FDW-executions.

#### Definition

```
AdvanceInitRequest (
 FSConnectionHandle IN INTEGER,
 RequestHandle IN INTEGER,
 ReplyHandle OUT INTEGER,
 ExecutionHandle OUT INTEGER,
 QueryContextHandle IN INTEGER)
RETURNS SMALLINT
```

#### General Rules

- 1) Let *FSCH* be the value of *FSConnectionHandle*.
- 2) If *FSCH* does not identify an allocated *FSconnection*, then an exception condition is raised: *FDW-specific condition — invalid handle*.
- 3) Let *QCH* be the value of *QueryContextHandle*.
- 4) If *QCH* does not identify an allocated query context, then an exception condition is raised: *FDW-specific condition — invalid handle*.
- 5) Let *RQH* be the value of *RequestHandle*.
- 6) A set *SRH* of pairs of reply handles and corresponding execution handles is created as follows:
  - a) Let *RPH<sub>i</sub>* and *EXH<sub>i</sub>* be the *ReplyHandle* and *ExecutionHandle*, respectively, that would be returned by an invocation of *InitRequest* ( ) with *FSCH* and *RQH* as input arguments.
  - b) *RPH<sub>i</sub>* and *EXH<sub>i</sub>* are the *i*-th pair included in *SRH*.
- 7) Let *RPH* and *EXH* be a pair of reply handle and execution handle included in *SRH*, chosen in a foreign-data wrapper implementation-dependent way.
- 8) *ReplyHandle* is set to *RPH*.
- 9) *ExecutionHandle* is set to *EXH*.

## Conformance Rules

- 1) Without Feature M010, “Foreign-data wrapper support”, a conforming SQL-server shall not contain an invocation of a <foreign-data wrapper interface routine> that contains a <foreign-data wrapper interface routine name> that contains AdvanceInitRequest.

### 22.3.2 AllocQueryContext

#### Function

Allocate a query context and assign a handle to it.

#### Definition

```
AllocQueryContext (
 FSConnectionHandle IN INTEGER,
 QueryContextHandle OUT INTEGER)
RETURNS SMALLINT
```

#### General Rules

- 1) Let *FSCH* be the value of FSConnectionHandle.
- 2) If *FSCH* does not identify an allocated FSConnection, then an exception condition is raised: *FDW-specific condition — invalid handle*.
- 3) If the foreign-data wrapper implementation-dependent maximum number of query contexts that can be allocated at one time has already been reached, then an exception condition is raised: *FDW-specific condition — limit on number of handles exceeded*. A skeleton query context is allocated and is assigned a unique value that is returned in QueryContextHandle.
- 4) Case:
  - a) If the memory requirements to manage a query context cannot be satisfied, then QueryContextHandle is set to 0 (zero) and an exception condition is raised: *FDW-specific condition — memory allocation error*.  
 NOTE 61 — No diagnostic information is generated in this case, as there is no valid QueryContextHandle that can be used to obtain diagnostics information.
  - b) If the resources to manage a query context cannot be allocated for foreign-data wrapper implementation-defined reasons, then an implementation-defined exception condition is raised. A skeleton query context is allocated and is assigned a unique value that is returned in QueryContextHandle.
  - c) Otherwise, the resources to manage a query context are allocated and are referred to as an *allocated query context*. The allocated query context is assigned a unique value that is returned in QueryContextHandle.

#### Conformance Rules

- 1) Without Feature M010, “Foreign-data wrapper support”, a conforming SQL-server shall not contain an invocation of a <foreign-data wrapper interface routine> that contains a <foreign-data wrapper interface routine name> that contains AllocQueryContext.

### 22.3.3 AllocWrapperEnv

## Function

Allocate a foreign-data wrapper environment and assign a handle to it.

## Definition

```
AllocWrapperEnv (
 WrapperHandle IN INTEGER ,
 WrapperEnvHandle OUT INTEGER)
RETURNS SMALLINT
```

## General Rules

- 1) Let *WH* be the value of WrapperHandle.
- 2) If *WH* does not identify an allocated foreign-wrapper description, then an exception condition is raised: *FDW-specific condition — invalid handle*.
- 3) If the implementation-defined maximum number of foreign-data wrapper environments that can be allocated at one time has already been reached, then an exception condition is raised: *FDW-specific condition — limit on number of handles exceeded*. A skeleton FDW-environment is allocated and is assigned a unique value that is returned in WrapperEnvHandle.
- 4) Case:
  - a) If the memory requirements to manage an foreign-data wrapper environment cannot be satisfied, then WrapperEnvHandle is set to zero and an exception condition is raised: *FDW-specific condition — memory allocation error*.  
 NOTE 62 — No diagnostic information is generated in this case, as there is no valid WrapperEnvHandle that can be used to obtain diagnostics information.
  - b) If the resources to manage an foreign-data wrapper environment cannot be allocated for implementation-defined reasons, then an implementation-defined exception condition is raised. A skeleton FDW-environment is allocated and is assigned a unique value that is returned in WrapperEnvHandle.
  - c) Otherwise, the resources to manage an foreign-data wrapper environment are allocated and are referred to as an *allocated FDW-environment*. The allocated FDW-environment is assigned a unique value that is returned in WrapperEnvHandle.
- 5) If an exception condition is raised in any of the routines invoked in any of the following General Rules, then the diagnostics records returned by the invoked routines are transferred to the diagnostics area associated with the WrapperEnvHandle and further processing of this routine is terminated as if the exception condition had been raised in this routine.
- 6) Let *WN* be the WrapperName that would be returned by an invocation of GetWrapperName ( ) with *WH* as the WrapperHandle parameter.

**22.3 Foreign-data wrapper interface wrapper routines**

- 7) Let *WL* be the `WrapperLibraryName` that would be returned by an invocation of `GetWrapperLibraryName ( )` with *WH* as the `WrapperHandle` parameter.
- 8) It is implementation-dependent what use the `AllocWrapperEnv ( )` routine makes of the values of *WN* and *WL*.

**Conformance Rules**

- 1) Without Feature M010, “Foreign-data wrapper support”, a conforming SQL-server shall not contain an invocation of a <foreign-data wrapper interface routine> that contains a <foreign-data wrapper interface routine name> that contains `AllocWrapperEnv`.

### 22.3.4 Close

#### Function

Close an FDW-execution.

#### Definition

```
Close (
 ExecutionHandle IN INTEGER)
RETURNS SMALLINT
```

#### General Rules

- 1) Let *EH* be the value of ExecutionHandle.
- 2) If *EH* does not identify an opened FDW-execution, then an exception condition is raised: *FDW-specific condition — function sequence error*.
- 3) Let *E* be the opened FDW-execution identified by *EH*.
- 4) Case:
  - a) If there is no open cursor associated with *E*, then an exception condition is raised: *invalid cursor state*.
  - b) Otherwise:
    - i) The open cursor associated with *E* is placed in the closed state and its copy of the select source is destroyed.
    - ii) Any fetched row associated with *E* is removed from association with *E*.
- 5) *EH* is reset to be an allocated FDW-execution.

#### Conformance Rules

- 1) Without Feature M010, “Foreign-data wrapper support”, a conforming SQL-server shall not contain an invocation of a <foreign-data wrapper interface routine> that contains a <foreign-data wrapper interface routine name> that contains Close.

### 22.3.5 ConnectServer

## Function

Establish a connection to a foreign server and assign a handle to it.

## Definition

```
ConnectServer (
 WrapperEnvHandle IN INTEGER,
 ServerHandle IN INTEGER,
 UserHandle IN INTEGER,
 FSConnectionHandle OUT INTEGER)
RETURNS SMALLINT
```

## General Rules

- 1) If WrapperEnvHandle does not identify an allocated FDW-environment, then an exception condition is raised: *FDW-specific condition — invalid handle*.
- 2) Let *SH* be the value of ServerHandle.
- 3) If *SH* does not identify an allocated foreign server description, then an exception condition is raised: *FDW-specific condition — invalid handle*.
- 4) Let *UH* be the value of UserHandle.
- 5) If *UH* does not identify an allocated user mapping description, then an exception condition is raised: *FDW-specific condition — invalid handle*.
- 6) If an exception condition is raised in any of the routines invoked in any of the following General Rules, then the diagnostics records returned by the invoked routines are transferred to the foreign-data wrapper diagnostics area associated with the WrapperEnvHandle and further processing of this routine is terminated as if the exception condition had been raised in this routine.
- 7) Let *UN* be the AuthorizationId that would be returned by an invocation of GetAuthorizationId() with *UH* as the UserHandle parameter.
- 8) Let *SN* be the ServerName that would be returned by an invocation of GetServerName() with *SH* as the ServerHandle parameter.
- 9) Let *ST* be the ServerType that would be returned by an invocation of GetServerType() with *SH* as the ServerHandle parameter.
- 10) Let *SV* be the ServerVersion that would be returned by an invocation of GetServerVersion() with *SH* as the ServerHandle parameter.
- 11) Let *E* be the FDW-environment identified by WrapperEnvHandle.
- 12) The foreign-data wrapper diagnostics area associated with *E* is emptied.

**22.3 Foreign-data wrapper interface wrapper routines**

- 13) If the implementation-defined maximum number of FS-connections that can be allocated at one time has already been reached, then FSConnectionHandle is set to zero and an exception condition is raised: *FDW-specific condition — limit on number of handles exceeded.*
- 14) Case:
  - a) If the memory requirements to manage an FS-connection cannot be satisfied, then FSConnectionHandle is set to zero and an exception condition is raised: *FDW-specific condition — memory allocation error.*
  - b) If the resources to manage an FS-connection cannot be allocated for implementation-defined reasons, then FSConnectionHandle is set to zero and an implementation-defined exception condition is raised.
  - c) Otherwise, the resources to manage an FS-connection are allocated and are referred to as an allocated FS-connection. The allocated FS-connection is assigned a unique value that is returned in FSConnectionHandle.
- 15) Case:
  - a) If a connection to *FS* cannot be made, then an exception condition is raised: *FDW-specific condition — unable to establish connection.*
  - b) Otherwise, the connection to *FS* is established.
- 16) It is implementation-dependent what use the foreign-data wrapper makes of the values of *UN*, *SN*, *ST*, and *SV*.

**Conformance Rules**

- 1) Without Feature M010, “Foreign-data wrapper support”, a conforming SQL-server shall not contain an invocation of a <foreign-data wrapper interface routine> that contains a <foreign-data wrapper interface routine name> that contains ConnectServer.



### 22.3.6 FreeExecutionHandle

#### Function

Deallocate an FDW-execution.

#### Definition

```
FreeExecutionHandle (
 ExecutionHandle IN INTEGER)
RETURNS SMALLINT
```

#### General Rules

- 1) Let *EH* be the value of ExecutionHandle.
- 2) If *EH* does not identify an allocated FDW-execution, then an exception condition is raised: *FDW-specific condition — invalid handle*.
- 3) Let *E* be the FDW-execution identified by *EH*.
- 4) The foreign-data wrapper diagnostics area associated with *E* is emptied.
- 5) If there is an open cursor associated with *E*, then:
  - a) The open cursor associated with *E* is placed in the closed state and its copy of the select source is destroyed.
  - b) Any fetched row associated with *E* is removed from association with *E*.
- 6) Case:
  - a) If the PASSTHROUGH flag associated with *EH* is *False*, then:
    - i) Let *SRD* be the server row descriptor associated with *E* and let *SRDHandle* be the descriptor handle that identifies *SRD*. The FreeDescriptor ( ) routine is invoked with *SRDHandle* as the DescriptorHandle parameter.
    - ii) Let *SPD* be the server parameter descriptor associated with *E* and let *SPDHandle* be the descriptor handle that identifies *SPD*. The FreeDescriptor ( ) routine is invoked with *SPDHandle* as the DescriptorHandle parameter.
  - b) Otherwise:
    - i) Let *SRD* be the server row descriptor associated with *E* and let *SRDHandle* be the descriptor handle that identifies *SRD*. The FreeDescriptor ( ) routine is invoked with *SRDHandle* as the DescriptorHandle parameter.
    - ii) Let *SPD* be the server parameter descriptor associated with *E* and let *SPDHandle* be the descriptor handle that identifies *SPD*. The FreeDescriptor ( ) routine is invoked with *SPDHandle* as the DescriptorHandle parameter.

**22.3 Foreign-data wrapper interface wrapper routines**

- iii) Let *WRD* be the wrapper row descriptor associated with *E* and let *WRDHandle* be the descriptor handle that identifies *WRD*. The `FreeDescriptor()` routine is invoked with *WRDHandle* as the `DescriptorHandle` parameter.
  - iv) Let *WPD* be the wrapper parameter descriptor associated with *E* and let *WPDHandle* be the descriptor handle that identifies *WPD*. The `FreeDescriptor()` routine is invoked with *WPDHandle* as the `DescriptorHandle` parameter.
- 7) *E* is deallocated and all its resources are freed.

**Conformance Rules**

- 1) Without Feature M010, “Foreign-data wrapper support”, a conforming SQL-server shall not contain an invocation of a <foreign-data wrapper interface routine> that contains a <foreign-data wrapper interface routine name> that contains `FreeExecutionHandle`.

### 22.3.7 FreeFSConnection

#### Function

Deallocate a FS-connection.

#### Definition

```
FreeFSConnection (
 FSConnectionHandle IN INTEGER)
RETURNS SMALLINT
```

#### General Rules

- 1) Let *FSCH* be the value of FSConnectionHandle.
- 2) If *FSCH* does not identify an allocated FS-connection, then an exception condition is raised: *FDW-specific condition — invalid handle*.
- 3) Let *C* be the allocated FS-connection identified by *FSCH*.
- 4) The foreign-data wrapper diagnostics area associated with *C* is emptied.
- 5) If an allocated query context is associated with *C*, then an exception condition is raised: *FDW-specific condition — function sequence error*.
- 6) *C* is deallocated and all its resources are freed.

#### Conformance Rules

- 1) Without Feature M010, “Foreign-data wrapper support”, a conforming SQL-server shall not contain an invocation of a <foreign-data wrapper interface routine> that contains a <foreign-data wrapper interface routine name> that contains FreeFSConnection.

### 22.3.8 FreeQueryContext

#### Function

Deallocate a query context.

#### Definition

```
FreeQueryContext (
 QueryContextHandle IN INTEGER)
RETURNS SMALLINT
```

#### General Rules

- 1) Let  $QCH$  be the value of QueryContextHandle.
- 2) If  $QCH$  does not identify an allocated query context, then an exception condition is raised: *FDW-specific condition — invalid handle*.
- 3) Let  $Q$  be the allocated query context identified by  $QCH$ .
- 4) The foreign-data wrapper diagnostics area associated with  $Q$  is emptied.
- 5) If an allocated reply description or FDW-execution is associated with  $Q$ , then an exception condition is raised: *FDW-specific condition — function sequence error*.
- 6)  $Q$  is deallocated and all its resources are freed.

#### Conformance Rules

- 1) Without Feature M010, “Foreign-data wrapper support”, a conforming SQL-server shall not contain an invocation of a <foreign-data wrapper interface routine> that contains a <foreign-data wrapper interface routine name> that contains FreeQueryContext.

### 22.3.9 FreeReplyHandle

#### Function

Deallocate an FDW-reply.

#### Definition

```
FreeReplyHandle (
 ReplyHandle IN INTEGER)
RETURNS SMALLINT
```

#### General Rules

- 1) Let *RH* be the value of ReplyHandle.
- 2) If *RH* does not identify an allocated reply description, then an exception condition is raised: *FDW-specific condition — invalid handle*.
- 3) Let *R* be the FDW-reply identified by *RH*.
- 4) The foreign-data wrapper diagnostics area associated with *R* is emptied.
- 5) *R* is deallocated and all its resources are freed.

#### Conformance Rules

- 1) Without Feature M010, “Foreign-data wrapper support”, a conforming SQL-server shall not contain an invocation of a <foreign-data wrapper interface routine> that contains a <foreign-data wrapper interface routine name> that contains FreeReplyHandle.

### 22.3.10 FreeWrapperEnv

#### Function

Deallocate a FDW-environment.

#### Definition

```
FreeWrapperEnv (
 WrapperEnvHandle IN INTEGER)
RETURNS SMALLINT
```

#### General Rules

- 1) Let *WEH* be the value of `WrapperEnvHandle`.
- 2) If *WEH* does not identify an allocated FDW-environment, then an exception condition is raised: *FDW-specific condition — invalid handle*.
- 3) Let *E* be the allocated FDW-environment identified by *WEH*.
- 4) The foreign-data wrapper diagnostics area associated with *E* is emptied.
- 5) If an allocated FS-connection is associated with *E*, then an exception condition is raised: *FDW-specific condition — function sequence error*.
- 6) *E* is deallocated and all its resources are freed.

#### Conformance Rules

- 1) Without Feature M010, “Foreign-data wrapper support”, a conforming SQL-server shall not contain an invocation of a <foreign-data wrapper interface routine> that contains a <foreign-data wrapper interface routine name> that contains `FreeWrapperEnv`.

### 22.3.11 GetNextReply

#### Function

Get a new reply handle and execution handle for a foreign server request.

#### Definition

```
GetNextReply (
 ReplyHandle IN INTEGER,
 NextReplyHandle OUT INTEGER,
 NextExecutionHandle OUT INTEGER)
RETURNS SMALLINT
```

#### General Rules

- 1) Let *RH* be the value of ReplyHandle.
- 2) If *RH* does not identify an allocated reply description, then an exception condition is raised: *FDW-specific condition — invalid handle*.
- 3) Let *SRH* be the set of reply handles that was allocated during the execution of the AdvanceInitRequest( ) routine during which *RH* was allocated.
- 4) Let *NRH* be a handle referencing an allocated reply description included in *SRH*.
- 5) Let *NEH* be the handle referencing an FDW-execution that corresponds to *NRH*.
- 6) NextReplyHandle is set to *NRH*.
- 7) NextExecutionHandle is set to *NEH*.

#### Conformance Rules

- 1) Without Feature M010, “Foreign-data wrapper support”, a conforming SQL-server shall not contain an invocation of a <foreign-data wrapper interface routine> that contains a <foreign-data wrapper interface routine name> that contains GetNextReply.

### 22.3.12 GetNumReplyBoolVE

#### Function

Get the number of <boolean value expression>s simply contained in the <where clause> of a query that the foreign-data wrapper is capable of handling.

#### Definition

```
GetNumReplyBoolVE (
 ReplyHandle IN INTEGER,
 NumberOfBoolVEs OUT INTEGER)
RETURNS SMALLINT
```

#### General Rules

- 1) Let *RH* be the value of ReplyHandle.
- 2) If *RH* does not identify an allocated reply description, then an exception condition is raised: *FDW-specific condition — invalid handle*.
- 3) Let *Q* be the query associated with *RH*.
- 4) Let *N* be the number of <boolean value expression> elements simply contained in the <where clause> of *Q* that the foreign-data wrapper is capable of handling.
- 5) NumberOfBoolVEs is set to *N*.

#### Conformance Rules

- 1) Without Feature M010, “Foreign-data wrapper support”, a conforming SQL-server shall not contain an invocation of a <foreign-data wrapper interface routine> that contains a <foreign-data wrapper interface routine name> that contains GetNumReplyBoolVE.



### 22.3.13 GetNumReplyOrderBy

#### Function

Get the number of columns that are used to order the result that the foreign-data wrapper is capable of handling.

#### Definition

```
GetNumReplyOrderBy (
 ReplyHandle IN INTEGER,
 NumberOfOrderByElems OUT SMALLINT)
RETURNS SMALLINT
```

#### General Rules

- 1) Let *RH* be the value of ReplyHandle.
- 2) If *RH* does not identify an allocated reply description, then an exception condition is raised: *FDW-specific condition — invalid handle*.
- 3) Let *NOE* be the number of <value expression>s used to order the result of the query associated with *RH* that the foreign-data wrapper is capable of handling.
- 4) NumberOfOrderByElems is set to *NOE*.

#### Conformance Rules

- 1) Without Feature M010, “Foreign-data wrapper support”, a conforming SQL-server shall not contain an invocation of a <foreign-data wrapper interface routine> that contains a <foreign-data wrapper interface routine name> that contains GetNumReplyOrderBy.

### 22.3.14 GetNumReplySelectElems

#### Function

Get the number of <value expressions>s in the <select list> of a query that the foreign-data wrapper is capable of handling.

#### Definition

```
GetNumReplySelectElems (
 ReplyHandle IN INTEGER,
 NumberOfSelectListElements OUT SMALLINT)
RETURNS SMALLINT
```

#### General Rules

- 1) Let *RH* be the value of ReplyHandle.
- 2) If *RH* does not identify an allocated reply description, then an exception condition is raised: *FDW-specific condition — invalid handle*.
- 3) Let *Q* be the query associated with *RH*.
- 4) Let *N* be the number of <value expression> elements simply contained in the <select list> of *Q* that the foreign-data wrapper is capable of handling.
- 5) NumberOfSelectListElements is set to *N*.

#### Conformance Rules

- 1) Without Feature M010, “Foreign-data wrapper support”, a conforming SQL-server shall not contain an invocation of a <foreign-data wrapper interface routine> that contains a <foreign-data wrapper interface routine name> that contains GetNumReplySelectElems.

### 22.3.15 GetNumReplyTableRefs

#### Function

Get the number of <table reference>s in the <from clause> of a query that can be processed by the foreign-data wrapper.

#### Definition

```
GetNumReplyTableRefs (
 ReplyHandle IN INTEGER,
 NumberOfTableReferences OUT SMALLINT)
RETURNS SMALLINT
```

#### General Rules

- 1) Let *RH* be the value of ReplyHandle.
- 2) If *RH* does not identify an allocated reply description, then an exception condition is raised: *FDW-specific condition — invalid handle*.
- 3) Let *Q* be the query associated with *RH*.
- 4) Let *N* be the number of <table reference> elements simply contained in the <from clause> of *Q* that the foreign-data wrapper is capable of handling.
- 5) NumberOfTableReferences is set to *N*.

#### Conformance Rules

- 1) Without Feature M010, “Foreign-data wrapper support”, a conforming SQL-server shall not contain an invocation of a <foreign-data wrapper interface routine> that contains a <foreign-data wrapper interface routine name> that contains GetNumReplyTableRefs.

### 22.3.16 GetOpts

#### Function

Request the foreign-data wrapper to supply information about the capabilities of a given object, and other information pertaining to that object.

#### Definition

```

GetOpts (
 InputHandle IN INTEGER,
 HandleType IN SMALLINT,
 ReturnFormat OUT INTEGER,
 Options OUT CHARACTER VARYING(L2) ,
 BufferLength IN INTEGER,
 StringLength OUT INTEGER)
RETURNS SMALLINT

```

where: *L2* is determined by the value of *StringLength* and has a maximum value equal to the implementation-defined maximum length of a variable-length character string.

#### General Rules

- 1) Let *IH* be the value of *InputHandle* and let *HT* be the value of *HandleType*.
- 2) If *HT* is not one of the code values in Table 31, “Codes used for foreign-data wrapper handle types”, then an exception condition is raised: *FDW-specific exception — invalid handle*.
- 3) If *IH* does not identify a handle of the type indicated by *HT*, then an exception condition is raised: *FDW-specific exception — invalid handle*.
- 4) Case:
  - a) If *HT* indicates WRAPPER HANDLE, then
 

Case:

    - i) If the foreign-data wrapper *FDW* described by *IH* cannot return a report of its capabilities and other information, then a completion condition is raised: *no data*.
    - ii) Otherwise, a description *CD* of the capabilities of *FDW* is created.
  - b) If *HT* indicates SERVER HANDLE, then
 

Case:

    - i) If the foreign server *FS* described by *IH* cannot return a report of its capabilities and other information, then a completion condition is raised: *no data*.
    - ii) Otherwise, a description *CD* of the capabilities of *FS* is created.

### 22.3 Foreign-data wrapper interface wrapper routines

If *CD* is an XML document, then it shall be a valid XML document according to the following DTD:

```
<?xml version="1.0" encoding="charencoding" ?>
<!-- SQL/MED GetOpts Document -->
<!-- UTF-8 and UTF-16 are the only required encodings -->
<!ELEMENT SQLMEDGenericOptions (SQLMEDGenericOption)+ >
 <!ELEMENT SQLMEDGenericOption (#PCDATA)>
 <!ATTLIST SQLMEDGenericOption SQLMEDOptionName CDATA #REQUIRED>
 <!ATTLIST SQLMEDGenericOption
 SQLMEDOptionType (INTEGER | CHARACTER) #REQUIRED>
```

where *charencoding* is either UTF-8 or UTF-16.

NOTE 63 — The CDATA value of the SQLMEDOptionName attribute and the PCDATA text of the SQLMEDGenericOption tag are implementation-defined.

NOTE 64 — The DTD can be internal to the XML document or it can be an external DTD referenced by a URI as specified in the XML specification. The way in which the foreign-data wrapper knows the URI to specify in the XML document is implementation-defined.

5) The General Rules of [Subclause 21.7, “Character string retrieval”](#), are applied to Options, *CD*, *LO*, and StringLength as *TARGET*, *VALUE*, *TARGET OCTET LENGTH*, and *RETURNED OCTET LENGTH*, respectively.

6) Case:

- a) If *CD* is an XML document, then the value of ReturnFormat is set to one (1).
- b) If *CD* is in a format defined by the foreign-data wrapper, then the value of ReturnFormat is set to a value, defined by the foreign-data wrapper, that corresponds to that format.

NOTE 65 — All negative values are reserved for use by foreign-data wrappers. All non-negative values are reserved for use by this International Standard.

## Conformance Rules

1) Without Feature M009, “GetOpts and GetStatistics routines”, a conforming SQL-server shall not contain an invocation of a <foreign-data wrapper interface routine> that contains a <foreign-data wrapper interface routine name> that contains GetOpts.

### 22.3.17 GetReplyBoolVE

#### Function

Get the ordinal position, within the <where clause> of a query, of a <boolean value expression> element that the foreign-data wrapper is capable of handling.

#### Definition

```
GetReplyBoolVE (
 ReplyHandle IN INTEGER,
 Index IN SMALLINT,
 BoolVNumber OUT SMALLINT)
RETURNS SMALLINT
```

#### General Rules

- 1) Let *RH* be the value of ReplyHandle.
- 2) If *RH* does not identify an allocated reply description, then an exception condition is raised: *FDW-specific condition — invalid handle*.
- 3) Let *I* be the value of Index.
- 4) If *I* is less than 1 (one), then an exception condition is raised: *FDW-specific condition — invalid option index*.
- 5) Let *Q* be the query associated with *RH*. Let *WCQ* be the <where clause> of *Q*.
- 6) Let *N* be the number of <boolean value expression> elements simply contained in *WCQ* that the foreign-data wrapper is capable of handling. Let *BVEH* be a list containing only those *N* <boolean value expression> elements, in the same relative positions in which they appear in *WCQ*.
- 7) If *I* is greater than *N*, then a completion condition is raised: *no data*, and no further rules of this Subclause are applied.
- 8) BoolVNumber is set to the ordinal position in *WCQ* of the <boolean value expression> element that is *I*-th within *BVEH*.

#### Conformance Rules

- 1) Without Feature M010, “Foreign-data wrapper support”, a conforming SQL-server shall not contain an invocation of a <foreign-data wrapper interface routine> that contains a <foreign-data wrapper interface routine name> that contains GetReplyBoolVE.

### 22.3.18 GetReplyCardinality

#### Function

Get an estimate of the cardinality of the result set associated with a given reply.

#### Definition

```
GetReplyCardinality (
 ReplyHandle IN INTEGER,
 ReplyCardinality OUT INTEGER)
RETURNS SMALLINT
```

#### General Rules

- 1) Let *RH* be the value of ReplyHandle.
- 2) If *RH* does not identify an allocated reply description, then an exception condition is raised: *FDW-specific condition — invalid handle*.
- 3) Let *C* be the estimated cardinality of the result set associated with *RH*.

NOTE 66 — If the foreign-data wrapper has no means to estimate the cardinality of the result set associated with *RH*, then *C* is a foreign-data wrapper implementation-dependent default value.

- 4) ReplyCardinality is set to *C*.

#### Conformance Rules

- 1) Without Feature M010, “Foreign-data wrapper support”, a conforming SQL-server shall not contain an invocation of a <foreign-data wrapper interface routine> that contains a <foreign-data wrapper interface routine name> that contains GetReplyCardinality.

### 22.3.19 GetReplyDistinct

#### Function

Get information as to whether the foreign-data wrapper is capable of providing distinct rows in the result set.

#### Definition

```
GetReplyDistinct (
 ReplyHandle IN INTEGER,
 IsDistinct OUT SMALLINT)
RETURNS SMALLINT
```

#### General Rules

- 1) Let *RH* be the value of ReplyHandle.
- 2) If *RH* does not identify an allocated reply description, then an exception condition is raised: *FDW-specific condition — invalid handle*.
- 3) Case:
  - a) If the foreign-data wrapper is capable of providing distinct rows in the result set, then IsDistinct is set to 1 (one).
  - b) Otherwise, IsDistinct is set to 0 (zero).

#### Conformance Rules

- 1) Without Feature M010, “Foreign-data wrapper support”, a conforming SQL-server shall not contain an invocation of a <foreign-data wrapper interface routine> that contains a <foreign-data wrapper interface routine name> that contains GetReplyDistinct.



### 22.3.20 GetReplyExecCost

#### Function

Get a value that represents the estimated “cost” to retrieve the result set associated with the reply. Larger values represent greater costs.

#### Definition

```
GetReplyExecCost (
 ReplyHandle IN INTEGER,
 ReplyTotalExecCost OUT INTEGER)
RETURNS SMALLINT
```

#### General Rules

- 1) Let *RH* be the value of ReplyHandle.
- 2) If *RH* does not identify an allocated reply description, then an exception condition is raised: *FDW-specific condition — invalid handle*.
- 3) Let *C* be the estimated cost to retrieve the result set associated with *RH*.

NOTE 67 — If the foreign-data wrapper has no means to estimate the cost to retrieve the result set associated with *RH*, then *C* is a foreign-data wrapper implementation-dependent default value.

- 4) ReplyTotalExecCost is set to *C*.

#### Conformance Rules

- 1) Without Feature M010, “Foreign-data wrapper support”, a conforming SQL-server shall not contain an invocation of a <foreign-data wrapper interface routine> that contains a <foreign-data wrapper interface routine name> that contains GetReplyExecCost.

### 22.3.21 GetReplyFirstCost

#### Function

Get a value that represents the estimated “cost” to retrieve the first row of the result set associated with the reply. Larger values represent greater costs.

#### Definition

```
GetReplyFirstCost (
 ReplyHandle IN INTEGER,
 ReplyExecFirstCost OUT INTEGER)
RETURNS SMALLINT
```

#### General Rules

- 1) Let *RH* be the value of ReplyHandle.
- 2) If *RH* does not identify an allocated reply description, then an exception condition is raised: *FDW-specific condition — invalid handle*.
- 3) Let *C* be the estimated cost to retrieve the first row of the result set associated with *RH*.

NOTE 68 — If the foreign-data wrapper has no means to estimate the cost to retrieve the first row of the result set associated with *RH*, then *C* is a foreign-data wrapper implementation-dependent default value.

- 4) ReplyExecFirstCost is set to *C*.

#### Conformance Rules

- 1) Without Feature M010, “Foreign-data wrapper support”, a conforming SQL-server shall not contain an invocation of a <foreign-data wrapper interface routine> that contains a <foreign-data wrapper interface routine name> that contains GetReplyFirstCost.

### 22.3.22 GetReplyOrderElem

#### Function

Get the ordinal position, within the <select list>, of a <value expression> element that the foreign-data wrapper is capable of handling and that is used to order the result of a query.

#### Definition

```
GetReplyOrderElem (
 ReplyHandle IN INTEGER,
 Index IN SMALLINT,
 OrderByNumber OUT SMALLINT)
RETURNS SMALLINT
```

#### General Rules

- 1) Let *RH* be the value of ReplyHandle.
- 2) If *RH* does not identify an allocated reply description, then an exception condition is raised: *FDW-specific condition — invalid handle*.
- 3) Let *I* be the value of Index.
- 4) If *I* is less than 1 (one), then an exception condition is raised: *FDW-specific condition — invalid option index*.
- 5) Let *Q* be the query associated with *RH*. Let *SLQ* be the <select list> of *Q*.
- 6) Let *N* be the number of <value expression> elements simply contained in *SLQ* that the foreign-data wrapper is capable of handling. Let *VEH* be a list containing only those *N* <value expression> elements, in the same relative positions in which they appear in *SLQ*.
- 7) If *I* is greater than *N*, then a completion condition is raised: *no data*, and no further rules of this Subclause are applied.
- 8) OrderByNumber is set to the ordinal position in *SLQ* of the <value expression> element that is *I*-th within *VEH*.

#### Conformance Rules

- 1) Without Feature M010, “Foreign-data wrapper support”, a conforming SQL-server shall not contain an invocation of a <foreign-data wrapper interface routine> that contains a <foreign-data wrapper interface routine name> that contains GetReplyOrderElem.

### 22.3.23 GetReplyReExecCost

#### Function

Get a value that represents the estimated “cost” to re-execute the reply identified by the provided reply handle. Larger values represent greater costs.

#### Definition

```
GetReplyReExecCost (
 ReplyHandle IN INTEGER,
 ReplyReExecutionCost OUT INTEGER)
RETURNS SMALLINT
```

#### General Rules

- 1) Let *RH* be the value of ReplyHandle.
- 2) If *RH* does not identify an allocated reply description, then an exception condition is raised: *FDW-specific condition — invalid handle*.
- 3) Let *C* be the estimated cost to re-execute the reply identified by *RH*.

NOTE 69 — If the foreign-data wrapper has no means to estimate the cost to re-execute *RH*, the *C* is a foreign-data wrapper implementation-dependent default value.

- 4) ReExecutionCost is set to *C*.

#### Conformance Rules

- 1) Without Feature M010, “Foreign-data wrapper support”, a conforming SQL-server shall not contain an invocation of a <foreign-data wrapper interface routine> that contains a <foreign-data wrapper interface routine name> that contains GetReplyReExecCost.

### 22.3.24 GetReplySelectElem

## Function

Get the ordinal position, within the <select list> of a query, of a <value expression> element that the foreign-data wrapper is capable of handling.

## Definition

```
GetReplySelectElem (
 ReplyHandle IN INTEGER,
 Index IN SMALLINT,
 SelectListElementNumber OUT SMALLINT)
RETURNS SMALLINT
```

## General Rules

- 1) Let *RH* be the value of ReplyHandle.
- 2) If *RH* does not identify an allocated reply description, then an exception condition is raised: *FDW-specific condition — invalid handle*.
- 3) Let *I* be the value of Index.
- 4) If *I* is less than 1 (one), then an exception condition is raised: *FDW-specific condition — invalid option index*.
- 5) Let *Q* be the query associated with *RH*. Let *SLQ* be the <select list> of *Q*.
- 6) Let *N* be the number of <value expression>s simply contained in *SLQ* that the foreign-data wrapper is capable of handling. Let *VEH* be a list containing only those *N* <value expression> elements, in the same relative positions in which they appear in *SLQ*.
- 7) If *I* is greater than *N*, then a completion condition is raised: *no data*, and no further rules of this Subclause are applied.
- 8) SelectListElementNumber is set to the ordinal position in *SLQ* of the <value expression> element that is *I*-th within *VEH*.

## Conformance Rules

- 1) Without Feature M010, “Foreign-data wrapper support”, a conforming SQL-server shall not contain an invocation of a <foreign-data wrapper interface routine> that contains a <foreign-data wrapper interface routine name> that contains GetReplySelectElem.

### 22.3.25 GetReplyTableRef

#### Function

Get the ordinal position, within the <from clause> of a query, of a <table reference> element that the foreign-data wrapper is capable of handling.

#### Definition

```
GetReplyTableRef (
 ReplyHandle IN INTEGER,
 Index IN SMALLINT,
 TableReferenceNumber OUT SMALLINT)
RETURNS SMALLINT
```

#### General Rules

- 1) Let *RH* be the value of ReplyHandle.
- 2) If *RH* does not identify an allocated reply description, then an exception condition is raised: *FDW-specific condition — invalid handle*.
- 3) Let *I* be the value of Index.
- 4) If *I* is less than 1 (one), then an exception condition is raised: *FDW-specific condition — invalid option index*.
- 5) Let *Q* be the query associated with *RH*. Let *FCQ* be the <from clause> of *Q*.
- 6) Let *N* be the number of <table reference>s simply contained in *FCQ* that the foreign-data wrapper is capable of handling. Let *TRH* be a list containing only those *N* <table reference>s, in the same relative positions in which they appear in *FCQ*.
- 7) If *I* is greater than *N*, then a completion condition is raised: *no data*, and no further rules of this Subclause are applied.
- 8) TableReferenceNumber is set to the ordinal position in *FCQ* of the <table reference> element that is *I*-th within *TRH*.

#### Conformance Rules

- 1) Without Feature M010, “Foreign-data wrapper support”, a conforming SQL-server shall not contain an invocation of a <foreign-data wrapper interface routine> that contains a <foreign-data wrapper interface routine name> that contains GetReplyTableRef.

### 22.3.26 GetSPDHandle

#### Function

Get the descriptor handle of the server parameter descriptor associated with a given ExecutionHandle.

#### Definition

```
GetSPDHandle (
 ExecutionHandle IN INTEGER,
 SPDHandle OUT INTEGER)
RETURNS SMALLINT
```

#### General Rules

- 1) Let *EH* be the value of ExecutionHandle.
- 2) If *EH* does not identify an allocated FDW-execution, then an exception condition is raised: *FDW-specific condition — invalid handle*.
- 3) SPDHandle is set to the descriptor handle of the server parameter descriptor associated with *EH*.

#### Conformance Rules

- 1) Without Feature M010, “Foreign-data wrapper support”, a conforming SQL-server shall not contain an invocation of a <foreign-data wrapper interface routine> that contains a <foreign-data wrapper interface routine name> that contains GetSPDHandle.

### 22.3.27 GetSRDHandle

#### Function

Get the descriptor handle of the server row descriptor associated with a given execution handle.

#### Definition

```
GetSRDHandle (
 ExecutionHandle IN INTEGER,
 SRDHandle OUT INTEGER)
RETURNS SMALLINT
```

#### General Rules

- 1) Let *EH* be the value of ExecutionHandle.
- 2) If *EH* does not identify an allocated FDW-execution, then an exception condition is raised: *FDW-specific condition — invalid handle*.
- 3) SRDHandle is set to the descriptor handle of the server row descriptor associated with *EH*.

#### Conformance Rules

- 1) Without Feature M010, “Foreign-data wrapper support”, a conforming SQL-server shall not contain an invocation of a <foreign-data wrapper interface routine> that contains a <foreign-data wrapper interface routine name> that contains GetSRDHandle.



### 22.3.28 GetStatistics

## Function

Retrieve implementation-defined statistics associated with a foreign server request.

## Definition

```
GetStatistics (
 ExecutionHandle IN INTEGER,
 ReturnFormat OUT INTEGER,
 Statistics OUT CHARACTER VARYING(L) ,
 BufferLength IN INTEGER,
 StringLength OUT INTEGER)
RETURNS SMALLINT
```

where: *L* is equal to the value of *StringLength* and has a maximum value equal to the implementation-defined maximum length of a variable-length character string.

## General Rules

- 1) Let *EH* be the value of *ExecutionHandle*.
- 2) If *EH* does not identify an allocated FDW-execution, then an exception condition is raised: *FDW-specific condition — invalid handle*.
- 3) Case:
  - a) If the foreign-data wrapper is able to report statistics associated with the foreign server request associated with *EH*, then a report of those statistics is created. If the report is in the form of an XML document, then it shall be a valid XML document according to the following DTD.

```
<?xml version="1.0" encoding="charencoding" ?>
<!-- SQL/MED GetStatistics Document -->
<!-- UTF-8 and UTF-16 are the only required encodings -->
<!ELEMENT SQLMEDStatisticsSet (SQLMEDStatistics)+ >
 <!ELEMENT SQLMEDStatistics (#PCDATA)>
 <!ATTLIST SQLMEDStatistics SQLMEDStatisticName CDATA #REQUIRED>
 <!ATTLIST SQLMEDStatistics
 SQLMEDStatisticType (INTEGER | CHARACTER) #REQUIRED>
```

where *charencoding* is either UTF-8 or UTF-16.

NOTE 70 — The CDATA values of the *SQLMEDStatisticName* attribute and the PCDATA text of the *SQLMEDStatistics* tag are implementation-defined.

NOTE 71 — The DTD can be internal to the XML document or it can be an external DTD referenced by a URI as specified in the XML specification. The way in which the foreign-data wrapper knows the URI to specify in the XML document is implementation-defined.

- b) Otherwise, a completion condition is raised: *no data*.

**22.3 Foreign-data wrapper interface wrapper routines**

- 4) The General Rules of [Subclause 21.7, “Character string retrieval”](#), are applied to Statistics, *SI*, *LOS*, and *StringLength* as *TARGET*, *VALUE*, *TARGET OCTET LENGTH*, and *RETURNED OCTET LENGTH*, respectively.
- 5) Case:
  - a) If *SI* is an XML document, then the value of *ReturnFormat* is set to one (1).
  - b) If *SI* is in a format defined by the foreign-data wrapper, then the value of *ReturnFormat* is set to a value defined by the foreign-data wrapper that corresponds to that format.

NOTE 72 — All negative values are reserved for use by foreign-data wrappers. All non-negative values are reserved for use by this part of ISO/IEC 9075.

**Conformance Rules**

- 1) Without Feature M009, “*GetOpts* and *GetStatistics* routines”, a conforming SQL-server shall not contain an invocation of a <foreign-data wrapper interface routine> that contains a <foreign-data wrapper interface routine name> that contains *GetStatistics*.

### 22.3.29 GetWPDHandle

#### Function

Get the descriptor handle of the wrapper parameter descriptor associated with a given execution handle.

#### Definition

```
GetWPDHandle (
 ExecutionHandle IN INTEGER,
 WPDHandle OUT INTEGER)
RETURNS SMALLINT
```

#### General Rules

- 1) Let *EH* be the value of ExecutionHandle.
- 2) If *EH* does not identify an allocated FDW-execution, then an exception condition is raised: *FDW-specific condition — invalid handle*.
- 3) WPDHandle is set to the descriptor handle of the wrapper parameter descriptor associated with *EH*.

#### Conformance Rules

- 1) Without Feature M010, “Foreign-data wrapper support”, a conforming SQL-server shall not contain an invocation of a <foreign-data wrapper interface routine> that contains a <foreign-data wrapper interface routine name> that contains GetWPDHandle.

### 22.3.30 GetWRDHandle

#### Function

Get the descriptor handle of the wrapper row descriptor associated with a given execution handle.

#### Definition

```
GetWRDHandle (
 ExecutionHandle IN INTEGER,
 WRDHandle OUT INTEGER)
RETURNS SMALLINT
```

#### General Rules

- 1) Let *EH* be the value of ExecutionHandle.
- 2) If *EH* does not identify an allocated FDW-execution, then an exception condition is raised: *FDW-specific condition — invalid handle*.
- 3) WRDHandle is set to the descriptor handle of the wrapper row descriptor associated with *EH*.

#### Conformance Rules

- 1) Without Feature M010, “Foreign-data wrapper support”, a conforming SQL-server shall not contain an invocation of a <foreign-data wrapper interface routine> that contains a <foreign-data wrapper interface routine name> that contains GetWRDHandle.

### 22.3.31 InitRequest

## Function

Determine whether a foreign-data wrapper can execute a given foreign server request.

## Definition

```
InitRequest (
 FSConnectionHandle IN INTEGER ,
 RequestHandle IN INTEGER ,
 ReplyHandle OUT INTEGER ,
 ExecutionHandle OUT INTEGER)
RETURNS SMALLINT
```

## General Rules

- 1) Let *FSCH* be the value of `FSConnectionHandle`.
- 2) If *FSCH* does not identify an allocated `FSConnection`, then an exception condition is raised: *FDW-specific condition — invalid handle*.
- 3) If an exception condition is raised in any of the routines invoked in any of the following General Rules, then the diagnostics records returned by the invoked routines are transferred to the foreign-data wrapper diagnostics area associated with the `FSConnectionHandle` and further processing of this routine is terminated as if the exception condition had been raised in this routine.
- 4) Let *RH* be the value of `RequestHandle`.
- 5) Let *IG* be the indication of whether `GetSQLString()` will be invoked or not. It is foreign-data wrapper implementation-dependent whether *IG* is *True* or *False*.

NOTE 73 — The only possible values for *IG* are *True* and *False*.

- 6) Case:
  - a) If *IG* is *True*, then let *SS* be the `SQLString` value returned by an invocation of `GetSQLString()` with *RH* as the `RequestHandle` parameter.
  - b) Otherwise:
    - i) Let *NTRE* be the `NumberOfTableReferenceElement` values that would be returned by an invocation of `GetNumTableRefElems()` with *RH* as the `RequestHandle` parameter.
    - ii) For 1 (one)  $\leq i \leq NTRE$ :
      - 1) Let *TRH<sub>i</sub>* be the `TableReferenceHandle` that would be returned by invocation of `GetTableRefElem()` with *RH* as the `RequestHandle` parameter and *i* as the `TableReferenceElementNumber` parameter.

## 22.3 Foreign-data wrapper interface wrapper routines

- 2) Let  $TRDH_i$  be the TableReferenceDescriptorHandle that would be returned by invocation of `GetTRDHandle()` with  $TRH_i$  as the TableReferenceHandle parameter.
  - 3) Let  $NC_i$  be the value of the COUNT descriptor field that would be returned by invocation of `GetDescriptor()` with  $TRDH_i$  as the DescriptorHandle parameter, 0 (zero) as the RecordNumber parameter, and the code for COUNT from Table 30, “Codes used for foreign-data wrapper descriptor fields”, as the FieldIdentifier parameter.
  - 4) For  $1 \text{ (one)} \leq j \leq NC_i$ , let  $DT_{ij}$  be the effective data type of the  $j$ -th column, as represented by the values of the TYPE, LENGTH, OCTET\_LENGTH, PRECISION, SCALE, DATETIME\_INTERVAL\_CODE, DATETIME\_INTERVAL\_PRECISION, CHARACTER\_SET\_CATALOG, CHARACTER\_SET\_SCHEMA, CHARACTER\_SET\_NAME, USER\_DEFINED\_TYPE\_CATALOG, USER\_DEFINED\_TYPE\_SCHEMA, USER\_DEFINED\_TYPE\_NAME, SCOPE\_CATALOG, SCOPE\_SCHEMA, and SCOPE\_NAME fields that would be returned by separate invocations of `GetDescriptor()` with  $TRDH_i$  as the DescriptorHandle parameter,  $j$  as the RecordNumber parameter, and the code for the fields TYPE, LENGTH, OCTET\_LENGTH, PRECISION, SCALE, DATETIME\_INTERVAL\_CODE, DATETIME\_INTERVAL\_PRECISION, CHARACTER\_SET\_CATALOG, CHARACTER\_SET\_SCHEMA, CHARACTER\_SET\_NAME, USER\_DEFINED\_TYPE\_CATALOG, USER\_DEFINED\_TYPE\_SCHEMA, USER\_DEFINED\_TYPE\_NAME, SCOPE\_CATALOG, SCOPE\_SCHEMA, and SCOPE\_NAME from Table 30, “Codes used for foreign-data wrapper descriptor fields”, as the FieldIdentifier parameter.
  - 5) Let  $TRT_i$  be the TableReferenceType that would be returned by an invocation of `GetTableRefElemType()` with  $TRH_i$  as the TableReferenceHandle parameter.
  - 6) Let  $TN_i$  be the TableName that would be returned by invocation of `GetTableRefTableName()` with  $TRH_i$  as the TableReferenceHandle parameter.
- iii) Let  $NSLE$  be the NumberOfSelectListElements that would be returned by an invocation of `GetNumSelectElems()` with  $RH$  as the RequestHandle parameter.
  - iv) For  $1 \text{ (one)} \leq k \leq NSLE$ , let  $VEH_k$  be the ValueExpressionHandle that would be returned by invocation of `GetSelectElem()` with  $RH$  as the RequestHandle parameter and  $k$  as the SelectListElementNumber parameter.
  - v) Let  $NBVE$  be the NumberOfBoolVE values that would be returned by invocation of `GetNumBoolVE()` with  $RH$  as the RequestHandle parameter.
  - vi) For  $1 \text{ (one)} \leq k \leq NBVE$ , let  $VEH_{k+NSLE}$  be the ValueExpressionHandle that would be returned by an invocation of `GetBoolVE()` with  $RH$  as the RequestHandle parameter, and  $k$  as the BoolVNumber parameter.
  - vii) For  $1 \text{ (one)} \leq m \leq NSLE+NBVE$ , let  $VET_m$  be the ValueExpressionKind that would be returned by an invocation of `GetValueExpKind()` with  $VEH_m$  as the ValueExpressionHandle parameter, and let  $CN_m$  be the ColumnName that would be returned by invocation of `GetValueExpColumnName()` with  $VEH_m$  as the ValueExpressionHandle parameter.

22.3 Foreign-data wrapper interface wrapper routines

- 7) If the implementation-defined maximum number of FDW-replies that can be allocated at one time has already been reached, then ReplyHandle is set to zero and an exception condition is raised: *FDW-specific condition — limit on number of handles exceeded*.
- 8) Case:
- a) If the memory requirements to manage an FDW-reply cannot be satisfied, then ReplyHandle is set to zero and an exception condition is raised: *FDW-specific condition — memory allocation error*.
  - b) If the resources to manage an FDW-reply cannot be allocated for implementation-defined reasons, then ReplyHandle is set to zero and an implementation-defined exception condition is raised.
  - c) Otherwise, the resources to manage an FDW-reply are allocated and are referred to as an *allocated reply description*. The allocated reply description is assigned a unique value that is returned in ReplyHandle.
- 9) Case:
- a) If *IG* is *False* and, for any reason, the foreign-data wrapper cannot create an FDW-reply that corresponds to *RH* as described by *NTRE*, (*TRH<sub>i</sub>*, *TRDH<sub>i</sub>*, *NC<sub>i</sub>*, *TRT<sub>i</sub>*, and *TN<sub>i</sub>*, for 1 (one) ≤ *i* ≤ *NTRE*), (*DT<sub>ij</sub>*, for 1 (one) ≤ *i* ≤ *NTRE* and 1 (one) ≤ *j* ≤ *NC<sub>i</sub>*), *NSLE*, and (*VEH<sub>k</sub>*, *VET<sub>k</sub>*, and *CN<sub>k</sub>*, for 1 (one) ≤ *k* ≤ *NSLE+NBVE*), then an exception condition is raised: *FDW-specific condition — unable to create reply*.  
NOTE 74 — One reason for raising this exception could be an Access Rule violation at the foreign server.
  - b) If *IG* is *True* and, for any reason, the foreign-data wrapper cannot create an FDW-reply that corresponds to *RH* as described by *SS*, then an exception condition is raised: *FDW-specific condition — unable to create reply*.
  - c) Otherwise, the FDW-reply corresponding to *RH* is created.
- 10) If the implementation-defined maximum number of FDW-executions that can be allocated at one time has already been reached, then ExecutionHandle is set to zero and an exception condition is raised: *FDW-specific condition — limit on number of handles exceeded*.
- 11) Case:
- a) If the memory requirements to manage an FDW-execution cannot be satisfied, then ExecutionHandle is set to zero and an exception condition is raised: *FDW-specific condition — memory allocation error*.
  - b) If the resources to manage an FDW-execution cannot be allocated for implementation-defined reasons, then ExecutionHandle is set to zero and an implementation-defined exception condition is raised.
  - c) Otherwise, the resources to manage an FDW-execution are allocated and are referred to as an *allocated execution description*. The allocated execution description is assigned a unique value that is returned in ExecutionHandle.
- 12) Case:
- a) If *IG* is *False* and the foreign-data wrapper cannot create an FDW-execution that corresponds to *RH* as described by *NTRE*, (*TRH<sub>i</sub>*, *TRDH<sub>i</sub>*, *NC<sub>i</sub>*, *TRT<sub>i</sub>*, and *TN<sub>i</sub>*, for 1 (one) ≤ *i* ≤ *NTRE*), (*DT<sub>ij</sub>*, for 1 (one) ≤ *i* ≤ *NTRE* and 1 (one) ≤ *j* ≤ *NC<sub>i</sub>*), *NSLE*, and (*VEH<sub>k</sub>*, *VET<sub>k</sub>*, and *CN<sub>k</sub>*, for 1 (one) ≤ *k* ≤ *NSLE+NBVE*), then an exception condition is raised: *FDW-specific condition — unable to create execution*.

## 22.3 Foreign-data wrapper interface wrapper routines

- b) If *IG* is *False* and the foreign-data wrapper cannot create an FDW-execution that corresponds to *RH* as described by *SS*, then an exception condition is raised: *FDW-specific condition — unable to create execution*.
- c) Otherwise, the FDW-execution corresponding to *RH* is created.

13) The PASSTHROUGH flag associated with the allocated FDW-execution is set to *False*.

14) Let *NIDA* be the number of item descriptor areas that are set up for the server row descriptor. Let *SRDHandle* be the DescriptorHandle that is returned by an invocation of the `AllocDescriptor()` routine with *NIDA* as the `MaxDetailAreas` parameter. Let *SRD* be the server row descriptor identified by *SRDHandle*. *SRD* is associated with the allocated FDW-execution.

For this descriptor area, fields with non-blank entries in Table 34, “Foreign-data wrapper descriptor field default values”, are set to the specified default values by the invocation of the `SetDescriptor()` routine with *SRDHandle* as the `DescriptorHandle` parameter and *r* as the `RecordNumber` parameter,  $1 \text{ (one)} \leq r \leq NIDA$ , and to the codes for the fields with non-blank entries in Table 34, “Foreign-data wrapper descriptor field default values”, from Table 30, “Codes used for foreign-data wrapper descriptor fields”, as the `Field-Identifier` parameter. All other fields in the item descriptor areas of *SRD* are initially undefined.

15) Let *NIDAP* be the number of item descriptor areas that are set up for the server parameter descriptor. Let *SPDHandle* be the DescriptorHandle that is returned by an invocation of the `AllocDescriptor()` routine with *NIDAP* as the `MaxDetailAreas` parameter. Let *SPD* be the server parameter descriptor identified by *SPDHandle*. *SPD* is associated with the allocated FDW-execution.

For this descriptor area, fields with non-blank entries in Table 34, “Foreign-data wrapper descriptor field default values”, are set to the specified default values by the invocation of the `SetDescriptor()` routine with *SPDHandle* as the `DescriptorHandle` parameter and *r* as the `RecordNumber` parameter,  $1 \text{ (one)} \leq r \leq NIDAP$ , and to the codes for the fields with non-blank entries in Table 34, “Foreign-data wrapper descriptor field default values”, from Table 30, “Codes used for foreign-data wrapper descriptor fields”, as the `Field-Identifier` parameter. All other fields in the item descriptor areas of *SPD* are initially undefined.

## Conformance Rules

- 1) Without Feature M010, “Foreign-data wrapper support”, a conforming SQL-server shall not contain an invocation of a <foreign-data wrapper interface routine> that contains a <foreign-data wrapper interface routine name> that contains `InitRequest`.



### 22.3.32 Iterate

## Function

Retrieve the next row from an FDW-execution.

## Definition

```
Iterate (
 ExecutionHandle IN INTEGER)
RETURNS SMALLINT
```

## General Rules

- 1) Let *EH* be the value of ExecutionHandle.
- 2) If *EH* does not identify an opened FDW-execution, then an exception condition is raised: *FDW-specific condition — function sequence error*.
- 3) Let *HL1* be the standard host language in which the SQL-server is written and let *HL2* be the standard host language in which the foreign-data wrapper is written.
- 4) Let *S* be the opened FDW-execution identified by ExecutionHandle.
- 5) Let *CR* be the open cursor effectively associated with *S* and let *T* be the table effectively associated with the open cursor.
- 6) Let *SRD* be the server row descriptor for *S* and let *N* be the value of the TOP\_LEVEL\_COUNT field of *SRD*.
- 7) Case:
  - a) If *HL1* and *HL2* are both pointer-supporting languages, then for each item descriptor area in *SRD* whose LEVEL is 0 (zero) in the first *AD* item descriptor areas of *SRD*, and for all of their subordinate descriptor areas, refer to a <target specification> whose corresponding item descriptor area has a non-zero value of DATA\_POINTER as a *bound target* and refer to the corresponding <select list> column as a *bound column*.
  - b) Otherwise, for each item descriptor area in *SRD* whose LEVEL is 0 (zero) in the first *AD* item descriptor areas of *SRD*, and for all of their subordinate descriptor areas, refer to a <target specification> as a *bound target* and refer to the corresponding <select list> column as a *bound column*.
- 8) Let *IDA* be the item descriptor area of *SRD* corresponding to the *i*-th bound target and let *TT* be the value of the TYPE field of *IDA*.
- 9) If *TT* indicates DEFAULT, then:
  - a) Case:
    - i) If the PASSTHROUGH flag associated with *EH* is *True*, then let *RD* be the wrapper row descriptor associated with *S*.

- ii) Otherwise, let *RD* be the table reference descriptor associated with *S*.
  - b) Let *CT*, *P*, and *SC* be the values of the TYPE, PRECISION, and SCALE fields, respectively, for the item descriptor area of *RD* corresponding to the *i*-th bound column.
  - c) The data type, precision, and scale of the <target specification> described by *IDA* are effectively set to *CT*, *P*, and *SC*, respectively, for the purposes of this invocation of Iterate() only.
- 10) If *T* is empty, or if *CR* is positioned after the end of the result set, then:
- a) *CR* is positioned after the last row of *T*.
  - b) No values are assigned to bound targets.
  - c) A completion condition is raised: *no data* and no further rules of this Subclause are applied.
- 11) Case:
- a) If the position of *CR* is before a row *NR*, then *CR* is positioned on row *NR*.
  - b) If the position of *CR* is on a row *OR* other than the last row, then *CR* is positioned on the row immediately after *OR*. Let *NR* be the row immediately after *OR*.
- 12) *NR* becomes the current row of *CR*.
- 13) Case:
- a) If an exception condition is raised during derivation of any <derived column> associated with *NR*, then there is no fetched row associated with *S*, but *NR* remains the current row of *CR*.
  - b) Otherwise:
    - i) *NR* becomes the fetched row associated with *S*.
    - ii) Let *SS* be the select source associated with *S*.
    - iii) The General Rules of Subclause 21.6, “Implicit FETCH USING clause”, are applied with *S* as *OPENED FDW-EXECUTION*.
    - iv) If an exception condition is raised during the derivation of any target value, then the values of all the bound targets are implementation-dependent and *CR* remains positioned on the current row.

## Conformance Rules

- 1) Without Feature M010, “Foreign-data wrapper support”, a conforming SQL-server shall not contain an invocation of a <foreign-data wrapper interface routine> that contains a <foreign-data wrapper interface routine name> that contains Iterate.

### 22.3.33 Open

## Function

Open an FDW-execution.

## Definition

```
Open (
 ExecutionHandle IN INTEGER)
RETURNS SMALLINT
```

## General Rules

- 1) Let *EH* be the value of ExecutionHandle.
- 2) If *EH* does not identify an allocated FDW-execution, then an exception condition is raised: *FDW-specific condition — invalid handle*.
- 3) If *EH* identifies an opened FDW-execution, then an exception condition is raised: *FDW-specific condition — function sequence error*.
- 4) Let *S* be the allocated FDW-execution identified by ExecutionHandle.
- 5) If the PASSTHROUGH flag associated with *EH* is *True*, then:
  - a) Let *SRD* be the SRDHandle that would be returned by an invocation of the GetSRDHandle ( ) routine with *EH* as the ExecutionHandle parameter. Let *SPD* be the SPDHandle that would be returned by an invocation of the GetSPDHandle ( ) routine with *EH* as the ExecutionHandle parameter. Let *WRD* be the WRDHandle that would be returned by an invocation of the GetWRDHandle ( ) routine with *EH* as the ExecutionHandle parameter. Let *WPD* be the WPDHandle that would be returned by an invocation of the GetWPDHandle ( ) routine with *EH* as the ExecutionHandle parameter.
  - b) Let *NCR* be the value of the COUNT descriptor field that would be returned by invocation of the GetDescriptor ( ) routine with *WRD* as the DescriptorHandle parameter, 0 (zero) as the Record-Number parameter, and the code for COUNT from Table 30, “Codes used for foreign-data wrapper descriptor fields”, as the FieldIdentifier parameter.
  - c) Let *DT<sub>j</sub>* be the effective data type of the *j*-th column, for 1 (one) ≤ *j* ≤ *NCR*, as represented by the values of the TYPE, LENGTH, OCTET\_LENGTH, PRECISION, SCALE, DATETIME\_INTERVAL\_CODE, DATETIME\_INTERVAL\_PRECISION, CHARACTER\_SET\_CATALOG, CHARACTER\_SET\_SCHEMA, CHARACTER\_SET\_NAME, USER\_DEFINED\_TYPE\_CATALOG, USER\_DEFINED\_TYPE\_SCHEMA, USER\_DEFINED\_TYPE\_NAME, SCOPE\_CATALOG, SCOPE\_SCHEMA, and SCOPE\_NAME fields that would be returned by separate invocations of the GetDescriptor ( ) routine with *WRD* as the DescriptorHandle parameter, *j* as the RecordNumber parameter, and the code for the fields TYPE, LENGTH, OCTET\_LENGTH, PRECISION, SCALE, DATETIME\_INTERVAL\_CODE, DATETIME\_INTERVAL\_PRECISION, CHARACTER\_SET\_CATALOG, CHARACTER\_SET\_SCHEMA, CHARACTER\_SET\_NAME, USER\_DEFINED\_TYPE\_CATALOG, USER\_DEFINED\_TYPE\_SCHEMA,

USER\_DEFINED\_TYPE\_NAME, SCOPE\_CATALOG, SCOPE\_SCHEMA, and SCOPE\_NAME from Table 30, “Codes used for foreign-data wrapper descriptor fields”, as the FieldIdentifier parameter. TYPE is one of the code values in Table 14, “Codes used for implementation data types in SQL/CLI”.

- d) Let  $TDT_j$  be the effective data type of the  $j$ -th <target specification>, for  $1 \text{ (one)} \leq j \leq NCR$ , as represented by the values of the TYPE, LENGTH, OCTET\_LENGTH, PRECISION, SCALE, DATETIME\_INTERVAL\_CODE, DATETIME\_INTERVAL\_PRECISION, CHARACTER\_SET\_CATALOG, CHARACTER\_SET\_SCHEMA, CHARACTER\_SET\_NAME, USER\_DEFINED\_TYPE\_CATALOG, USER\_DEFINED\_TYPE\_SCHEMA, USER\_DEFINED\_TYPE\_NAME, SCOPE\_CATALOG, SCOPE\_SCHEMA, and SCOPE\_NAME fields that would be set by separate invocations of the GetDescriptor() routine with  $SRD$  as the DescriptorHandle parameter,  $j$  as the RecordNumber parameter, and the code for the fields TYPE, LENGTH, OCTET\_LENGTH, PRECISION, SCALE, DATETIME\_INTERVAL\_CODE, DATETIME\_INTERVAL\_PRECISION, CHARACTER\_SET\_CATALOG, CHARACTER\_SET\_SCHEMA, CHARACTER\_SET\_NAME, USER\_DEFINED\_TYPE\_CATALOG, USER\_DEFINED\_TYPE\_SCHEMA, USER\_DEFINED\_TYPE\_NAME, SCOPE\_CATALOG, SCOPE\_SCHEMA, and SCOPE\_NAME from Table 30, “Codes used for foreign-data wrapper descriptor fields”, as the FieldIdentifier parameter. TYPE either indicates ROW or is one of the code values in Table 15, “Codes used for application data types in SQL/CLI”.
- e) For every  $DT_j$  and  $TDT_j$ ,  $1 \text{ (one)} \leq j \leq NCR$ :
- i) If  $DT_j$  is an array type and  $TDT_j$  is not an array locator type, then an exception condition is raised: *FDW-specific condition — invalid data type descriptors*.
  - ii) If  $DT_j$  is a multiset type and  $TDT_j$  is not a multiset locator data type, then an exception condition is raised: *FDW-specific condition — invalid data type descriptors*.
  - iii) If  $DT_j$  is a row type, then
 

Case:

    - 1) If  $TDT_j$  is not a row type, then an exception condition is raised: *FDW-specific condition — invalid data type descriptors*.
    - 2) If  $TDT_j$  is a row type and  $DT_j$  and  $TDT_j$  do not conform to the Syntax Rules of Subclause 9.16, “Data type identity”, in ISO/IEC 9075-2, then an exception condition is raised: *FDW-specific condition — invalid data type descriptors*.
  - iv) If  $DT_j$  and  $TDT_j$  are predefined types, then let  $HL$  be the standard programming language in which the invoking SQL-server is written. Let *operative data type correspondence table* be the data type correspondence table for  $HL$  as specified in Subclause 19.5, “SQL/CLI data type correspondences”. Refer to the two columns of the operative data type correspondence table as the “SQL data type column” and the “host data type column”.
 

Case:

    - 1) If the row that contains the SQL data type corresponding to  $DT_j$  in the SQL data type column of the operative data type correspondence table contains “None” in the host data type column, and  $TDT_j$  is not a character string type, then an exception condition is raised: *FDW-specific condition — invalid data type descriptors*.

## 22.3 Foreign-data wrapper interface wrapper routines

- 2) Otherwise, if  $DT_j$  and  $TDT_j$  do not conform to the Syntax Rules of Subclause 9.16, “Data type identity”, in ISO/IEC 9075-2, then an exception condition is raised: *FDW-specific condition — invalid data type descriptors*.
- v) If  $DT_j$  is a user-defined type, then an exception condition is raised: *FDW-specific condition — invalid data type descriptors*.
- f) Let  $NCP$  be the value of the COUNT descriptor field that would be returned by invocation of the `GetDescriptor()` routine with  $WPD$  as the DescriptorHandle parameter, 0 (zero) as the RecordNumber parameter, and the code for COUNT from Table 30, “Codes used for foreign-data wrapper descriptor fields”, as the FieldIdentifier parameter.
- g) Let  $PDT_j$  be the effective data type of the  $j$ -th parameter, for  $1 \text{ (one)} \leq j \leq NCP$ , as represented by the values of the TYPE, LENGTH, OCTET\_LENGTH, PRECISION, SCALE, DATETIME\_INTERVAL\_CODE, DATETIME\_INTERVAL\_PRECISION, CHARACTER\_SET\_CATALOG, CHARACTER\_SET\_SCHEMA, CHARACTER\_SET\_NAME, USER\_DEFINED\_TYPE\_CATALOG, USER\_DEFINED\_TYPE\_SCHEMA, USER\_DEFINED\_TYPE\_NAME, SCOPE\_CATALOG, SCOPE\_SCHEMA, and SCOPE\_NAME fields that would be returned by separate invocations of the `GetDescriptor()` routine with  $WPD$  as the DescriptorHandle parameter,  $j$  as the RecordNumber parameter, and the code for the fields TYPE, LENGTH, OCTET\_LENGTH, PRECISION, SCALE, DATETIME\_INTERVAL\_CODE, DATETIME\_INTERVAL\_PRECISION, CHARACTER\_SET\_CATALOG, CHARACTER\_SET\_SCHEMA, CHARACTER\_SET\_NAME, USER\_DEFINED\_TYPE\_CATALOG, USER\_DEFINED\_TYPE\_SCHEMA, USER\_DEFINED\_TYPE\_NAME, SCOPE\_CATALOG, SCOPE\_SCHEMA, and SCOPE\_NAME from Table 30, “Codes used for foreign-data wrapper descriptor fields”, as the FieldIdentifier parameter. TYPE is one of the code values in Table 14, “Codes used for implementation data types in SQL/CLI”.
- h) Let  $PTDT_j$  be the effective data type of the  $j$ -th <target specification>, for  $1 \text{ (one)} \leq j \leq NCP$ , as represented by the values of the TYPE, LENGTH, OCTET\_LENGTH, PRECISION, SCALE, DATETIME\_INTERVAL\_CODE, DATETIME\_INTERVAL\_PRECISION, CHARACTER\_SET\_CATALOG, CHARACTER\_SET\_SCHEMA, CHARACTER\_SET\_NAME, USER\_DEFINED\_TYPE\_CATALOG, USER\_DEFINED\_TYPE\_SCHEMA, USER\_DEFINED\_TYPE\_NAME, SCOPE\_CATALOG, SCOPE\_SCHEMA, and SCOPE\_NAME fields that would be returned by separate invocations of the `GetDescriptor()` routine with  $SPD$  as the DescriptorHandle parameter,  $j$  as the RecordNumber parameter, and the code for the fields TYPE, LENGTH, OCTET\_LENGTH, PRECISION, SCALE, DATETIME\_INTERVAL\_CODE, DATETIME\_INTERVAL\_PRECISION, CHARACTER\_SET\_CATALOG, CHARACTER\_SET\_SCHEMA, CHARACTER\_SET\_NAME, USER\_DEFINED\_TYPE\_CATALOG, USER\_DEFINED\_TYPE\_SCHEMA, USER\_DEFINED\_TYPE\_NAME, SCOPE\_CATALOG, SCOPE\_SCHEMA, and SCOPE\_NAME from Table 30, “Codes used for foreign-data wrapper descriptor fields”, as the FieldIdentifier parameter. TYPE either indicates ROW or is one of the code values in Table 15, “Codes used for application data types in SQL/CLI”.
- i) For every  $PDT_j$  and  $PTDT_j$ ,  $1 \text{ (one)} \leq j \leq NCP$ :
- i) If  $PDT_j$  is an array data type and  $PTDT_j$  is not an array locator data type, then an exception condition is raised: *FDW-specific condition — invalid data type descriptors*.
  - ii) If  $PDT_j$  is a multiset data type and  $PTDT_j$  is not a multiset locator data type, then an exception condition is raised: *FDW-specific condition — invalid data type descriptors*.
  - iii) If  $PDT_j$  is a row data type, then

Case:

- 1) If  $PTDT_j$  is not a row data type, then an exception condition is raised: *FDW-specific condition — invalid data type descriptors*.
  - 2) If  $PTDT_j$  is a row data type and  $PDT_j$  and  $PTDT_j$  do not conform to the Syntax Rules of Subclause 9.16, “Data type identity”, in ISO/IEC 9075-2, then an exception condition is raised: *FDW-specific condition — invalid data type descriptors*.
- iv) If  $PDT_j$  and  $PTDT_j$  are predefined data types, then let  $HL$  be the standard programming language in which the invoking SQL-server is written. Let *operative data type correspondence table* be the data type correspondence table for  $HL$  as specified in Subclause 19.5, “SQL/CLI data type correspondences”. Refer to the two columns of the operative data type correspondence table as the “SQL data type column” and the “host data type column”.

Case:

- 1) If the row that contains the SQL data type corresponding to  $PDT_j$  in the SQL data type column of the operative data type correspondence table contains “None” in the host data type column, and  $PTDT_j$  is not a character string type, then an exception condition is raised: *FDW-specific condition — invalid data type descriptors*.
  - 2) Otherwise, if  $PDT_j$  and  $PTDT_j$  do not conform to the Syntax Rules of Subclause 9.16, “Data type identity”, in ISO/IEC 9075-2, then an exception condition is raised: *FDW-specific condition — invalid data type descriptors*.
- v) If  $PDT_j$  is a user-defined type, then an exception condition is raised: *FDW-specific condition — invalid data type descriptors*.

6) Case:

- a) If the foreign server request associated with  $EH$  returns a set of rows, then:
  - i) The General Rules of Subclause 21.5, “Implicit EXECUTE USING and OPEN USING clauses”, are applied to 'OPEN' and  $S$  as *TYPE* and *ALLOCATED FDW-EXECUTION*, respectively.
  - ii) The General Rules of Subclause 21.2, “Implicit cursor”, are applied to  $S$  as *ALLOCATED FDW-EXECUTION*.
- b) Otherwise, the General Rules of Subclause 21.5, “Implicit EXECUTE USING and OPEN USING clauses”, are applied to 'EXECUTE' and  $S$ , as *TYPE* and *ALLOCATED FDW-EXECUTION*, respectively.

7)  $EH$  is said to be an *opened FDW-execution*.

## Conformance Rules

- 1) Without Feature M010, “Foreign-data wrapper support”, a conforming SQL-server shall not contain an invocation of a <foreign-data wrapper interface routine> that contains a <foreign-data wrapper interface routine name> that contains Open.

### 22.3.34 ReOpen

#### Function

Reopen an FDW-execution.

#### Definition

```
ReOpen (
 ExecutionHandle IN INTEGER)
RETURNS SMALLINT
```

#### General Rules

- 1) Let *EH* be the value of ExecutionHandle.
- 2) If *EH* does not identify an allocated FDW-execution, then an exception condition is raised: *FDW-specific condition — invalid handle*.
- 3) The General Rules of [Subclause 22.3.33, “Open”](#), are applied with *EH* as the ExecutionHandle parameter.

#### Conformance Rules

- 1) Without Feature M010, “Foreign-data wrapper support”, a conforming SQL-server shall not contain an invocation of a <foreign-data wrapper interface routine> that contains a <foreign-data wrapper interface routine name> that contains ReOpen.

### 22.3.35 TransmitRequest

#### Function

Transmit a foreign server request to be analyzed by the foreign server.

#### Definition

```
TransmitRequest (
 FSConnectionHandle IN INTEGER,
 RequestString IN CHARACTER VARYING (L),
 StringLength IN INTEGER,
 ExecutionHandle OUT INTEGER)
RETURNS SMALLINT
```

where: *L* is equal to the value of *StringLength* and has a maximum value equal to the implementation-defined maximum length of a variable-length character string.

#### General Rules

- 1) Let *FSCH* be the value of *FSConnectionHandle*.
- 2) If *FSCH* does not identify an allocated FS-connection, then an exception condition is raised: *FDW-specific condition — invalid handle*.
- 3) Let *C* be the allocated FS-connection identified by *FSCH*.
- 4) The foreign-data wrapper diagnostics area associated with *C* is emptied.
- 5) Let *FR* be the foreign server request associated with the *RequestString*.
- 6) If the implementation-defined maximum number of FDW-executions that can be allocated at one time has already been reached, then *ExecutionHandle* is set to zero and an exception condition is raised: *FDW-specific condition — limit on number of handles exceeded*.
- 7) Case:
  - a) If the memory requirements to manage an FDW-execution cannot be satisfied, then *ReplyHandle* is set to zero and an exception condition is raised: *FDW-specific condition — memory allocation error*.
  - b) If the resources to manage an FDW-execution cannot be allocated for implementation-defined reasons, then *ReplyHandle* is set to zero and an implementation-defined exception condition is raised.
  - c) Otherwise, the resources to manage an FDW-execution are allocated and are referred to as an *allocated FDW-execution*. The allocated FDW-execution is assigned a unique value *RHV* that is returned in *ExecutionHandle*.
- 8) Case:
  - a) If the foreign-data wrapper cannot create an FDW-execution that corresponds to *FR*, then an exception condition is raised: *FDW-specific condition — unable to create reply*.



## 22.3 Foreign-data wrapper interface wrapper routines

b) Otherwise, the FDW-execution corresponding to *FR* is created.

9) The PASSTHROUGH flag associated with the allocated FDW-execution is set to *True*.

10) Let *SRDItemDescriptorAreas* be the number of item descriptor areas that need to be set up for the server row descriptor. Let *SRDHandle* be the DescriptorHandle that is returned by invocation of the `AllocDescriptor()` with *SRDItemDescriptorAreas* as the `MaxDetailAreas` parameter. Let *SRD* be the server row descriptor identified by *SRDHandle*. *SRD* is associated with the allocated FDW-execution.

For this descriptor, fields with non-blank entries in Table 34, “Foreign-data wrapper descriptor field default values”, are set to the specified default values by invocation of the `SetDescriptor()` with *SRDHandle* as the `DescriptorHandle` parameter and *r* as the `RecordNumber` parameter,  $1 \text{ (one)} \leq r \leq \textit{SRDItemDescriptorAreas}$ , and the code for the fields with non-blank entries in Table 34, “Foreign-data wrapper descriptor field default values”, from Table 30, “Codes used for foreign-data wrapper descriptor fields”, as the `Field-Identifier` parameter. All other fields in the item descriptor areas of *SRD* are initially undefined.

11) Let *SPDItemDescriptorAreas* be the number of item descriptor areas that need to be set up for the server parameter descriptor. Let *SPDHandle* be the DescriptorHandle that is returned by invocation of the `AllocDescriptor()` with *SPDItemDescriptorAreas* as the `MaxDetailAreas` parameter. Let *SPD* be the server parameter descriptor identified by *SPDHandle*. *SPD* is associated with the allocated FDW-execution.

For this descriptor, fields with non-blank entries in Table 34, “Foreign-data wrapper descriptor field default values”, are set to the specified default values by invocation of the `SetDescriptor()` with *SPDHandle* as the `DescriptorHandle` parameter and *r* as the `RecordNumber` parameter,  $1 \text{ (one)} \leq r \leq \textit{SPDItemDescriptorAreas}$ , and the code for the fields with non-blank entries in Table 34, “Foreign-data wrapper descriptor field default values”, from Table 30, “Codes used for foreign-data wrapper descriptor fields”, as the `Field-Identifier` parameter. All other fields in the item descriptor areas of *SPD* are initially undefined.

12) Let *WRDItemDescriptorAreas* be the number of item descriptor areas that need to be set up for the wrapper row descriptor. Let *WRDHandle* be the DescriptorHandle that is returned by invocation of the `AllocDescriptor()` with *WRDItemDescriptorAreas* as the `MaxDetailAreas` parameter. Let *WRD* be the wrapper row descriptor identified by *WRDHandle*. *WRD* is associated with the allocated FDW-execution.

For this descriptor, fields with non-blank entries in Table 34, “Foreign-data wrapper descriptor field default values”, are set to the specified default values by invocation of the `SetDescriptor()` with *WRDHandle* as the `DescriptorHandle` parameter and *r* as the `RecordNumber` parameter,  $1 \text{ (one)} \leq r \leq \textit{WRDItemDescriptorAreas}$ , and the code for the fields with non-blank entries in Table 34, “Foreign-data wrapper descriptor field default values”, from Table 30, “Codes used for foreign-data wrapper descriptor fields”, as the `Field-Identifier` parameter. All other fields in the item descriptor areas of *WRD* are initially undefined.

13) Let *WPDItemDescriptorAreas* be the number of item descriptor areas that need to be set up for the wrapper parameter descriptor. Let *WPDHandle* be the DescriptorHandle that is returned by invocation of the `AllocDescriptor()` with *WPDItemDescriptorAreas* as the `MaxDetailAreas` parameter. Let *WPD* be the wrapper parameter descriptor identified by *WPDHandle*. *WPD* is associated with the allocated FDW-execution.

For this descriptor, fields with non-blank entries in Table 34, “Foreign-data wrapper descriptor field default values”, are set to the specified default values by invocation of the `SetDescriptor()` with *WPDHandle* as the `DescriptorHandle` parameter and *r* as the `RecordNumber` parameter,  $1 \text{ (one)} \leq r \leq \textit{WPDItemDescriptorAreas}$ , and the code for the fields with non-blank entries in Table 34, “Foreign-data wrapper descriptor field default values”, from Table 30, “Codes used for foreign-data wrapper descriptor fields”, as the `Field-Identifier` parameter. All other fields in the item descriptor areas of *WPD* are initially undefined.

**22.3 Foreign-data wrapper interface wrapper routines**

- 14) The General Rules of Subclause 21.4, “Implicit DESCRIBE OUTPUT USING clause”, are applied with RequestString and *WRD* as *SOURCE* and *DESCRIPTOR*, respectively.
- 15) The General Rules of Subclause 21.3, “Implicit DESCRIBE INPUT USING clause”, are applied with RequestString and *WPD* as *SOURCE* and *DESCRIPTOR*, respectively.

**Conformance Rules**

- 1) Without Feature M007, “TransmitRequest”, a conforming SQL-server shall not contain an invocation of a <foreign-data wrapper interface routine> that contains a <foreign-data wrapper interface routine name> that contains TransmitRequest.

## 22.4 Foreign-data wrapper interface SQL-server routines

### 22.4.1 AllocDescriptor

#### Function

Allocate a foreign-data wrapper descriptor area and assign a handle to it.

#### Definition

```
AllocDescriptor (
 MaxDetailAreas IN SMALLINT,
 DescriptorHandle OUT INTEGER)
RETURNS SMALLINT
```

#### General Rules

- 1) Let *MDA* be the value of MaxDetailAreas.
- 2) If the implementation-defined maximum number of foreign-data wrapper descriptor areas that can be allocated at one time has already been reached, then DescriptorHandle is set to 0 (zero) and an exception condition is raised: *FDW-specific condition — limit on number of handles exceeded*.
- 3) Case:
  - a) If the memory requirements to manage a foreign-data wrapper descriptor area having *MDA* item descriptor areas cannot be satisfied, then DescriptorHandle is set to 0 (zero) and an exception condition is raised: *FDW-specific condition — memory allocation error*.
  - b) If the resources to manage a foreign-data wrapper descriptor area cannot be allocated for implementation-defined reasons, then DescriptorHandle is set to 0 (zero) and an implementation-defined exception condition is raised.
  - c) Otherwise, the resources to manage a foreign-data wrapper descriptor area are allocated and are referred to as an *allocated foreign-data wrapper descriptor area*. The allocated foreign-data wrapper descriptor area is assigned a unique value that is returned in DescriptorHandle.

#### Conformance Rules

- 1) Without Feature M030, “SQL-server foreign data support”, a conforming foreign-data wrapper shall not contain an invocation of a <foreign-data wrapper interface routine> that contains a <foreign-data wrapper interface routine name> that contains AllocDescriptor.

## 22.4.2 FreeDescriptor

### Function

Release resources associated with a foreign-data wrapper descriptor area.

### Definition

```
FreeDescriptor (
 DescriptorHandle IN INTEGER)
RETURNS SMALLINT
```

### General Rules

- 1) Let *DH* be the value of DescriptorHandle.
- 2) If *DH* does not identify an allocated foreign-data wrapper descriptor area, then an exception condition is raised: *FDW-specific condition — invalid handle*.
- 3) Let *D* be the allocated foreign-data wrapper descriptor area identified by *DH*.
- 4) *D* is deallocated and all its resources are freed.

### Conformance Rules

- 1) Without Feature M030, “SQL-server foreign data support”, a conforming foreign-data wrapper shall not contain an invocation of a <foreign-data wrapper interface routine> that contains a <foreign-data wrapper interface routine name> that contains FreeDescriptor.

### 22.4.3 GetAuthorizationId

## Function

Get the authorization identifier associated with a user mapping.

## Definition

```
GetAuthorizationId (
 UserHandle IN INTEGER,
 AuthorizationId OUT CHARACTER(L),
 BufferLength IN SMALLINT,
 StringLength OUT SMALLINT)
RETURNS SMALLINT
```

where *L* has a maximum value equal to the implementation-defined maximum length of an <identifier>.

## General Rules

- 1) Let *UH* be the value of UserHandle.
- 2) If *UH* does not identify an allocated user mapping description, then an exception condition is raised: *FDW-specific condition — invalid handle*.
- 3) Let *AID* be the authorization identifier associated with *UH*.
- 4) Let *BL* be the value of BufferLength.
- 5) The General Rules of [Subclause 21.7, “Character string retrieval”](#), are applied to AuthorizationId, *AID*, *BL*, StringLength as *TARGET*, *VALUE*, *TARGET OCTET LENGTH*, and *RETURNED OCTET LENGTH*, respectively.

## Conformance Rules

- 1) Without Feature M030, “SQL-server foreign data support”, a conforming foreign-data wrapper shall not contain an invocation of a <foreign-data wrapper interface routine> that contains a <foreign-data wrapper interface routine name> that contains GetAuthorizationId.

### 22.4.4 GetBoolVE

#### Function

Get a handle for a <boolean value expression> from the <where clause> of a query.

#### Definition

```
GetBoolVE (
 RequestHandle IN INTEGER,
 BoolVENumber IN SMALLINT,
 ValueExpressionHandle OUT INTEGER)
RETURNS SMALLINT
```

#### General Rules

- 1) Let *RH* be the value of RequestHandle.
- 2) If *RH* does not identify an allocated request description, then an exception condition is raised: *FDW-specific condition — invalid handle*.
- 3) Let *BVEN* be the value of BoolVENumber.
- 4) If *BVEN* is less than 1 (one), then an exception condition is raised: *FDW-specific condition — invalid option index*.
- 5) Let *Q* be the query associated with *RH*.
- 6) Let *N* be the number of <boolean value expression>s simply contained in the <where clause> of *Q*.
- 7) If *BVEN* is greater than *N*, then a completion condition is raised: *no data*, and no further rules of this Sub-clause are applied.
- 8) ValueExpressionHandle is set to the value expression handle associated with the *BVEN*-th <boolean value expression>.

#### Conformance Rules

- 1) Without Feature M030, “SQL-server foreign data support”, a conforming foreign-data wrapper shall not contain an invocation of a <foreign-data wrapper interface routine> that contains a <foreign-data wrapper interface routine name> that contains GetBoolVE.

### 22.4.5 GetDescriptor

#### Function

Get the value of a field from a foreign-data wrapper descriptor area.

#### Definition

```
GetDescriptor (
 DescriptorHandle IN INTEGER,
 RecordNumber IN SMALLINT,
 FieldIdentifier IN SMALLINT,
 Value OUT ANY,
 BufferLength IN INTEGER,
 StringLength OUT INTEGER)
RETURNS SMALLINT
```

#### General Rules

- 1) Let *D* be the allocated foreign-data wrapper descriptor area identified by *DescriptorHandle* and let *N* be the value of the COUNT field of *D*.
- 2) Let *FI* be the value of *FieldIdentifier*.
- 3) If *FI* is not one of the code values in Table 30, “Codes used for foreign-data wrapper descriptor fields”, then an exception condition is raised: *FDW-specific condition — invalid descriptor field identifier*.
- 4) Let *RN* be the value of *RecordNumber*.
- 5) Let *TYPE* be the value of the Type column in the row of Table 30, “Codes used for foreign-data wrapper descriptor fields”, that contains *FI*.
- 6) If *TYPE* is 'ITEM', then:
  - a) If *RN* is less than 1 (one), then an exception condition is raised: *dynamic SQL error — invalid descriptor index*.
  - b) If *RN* is greater than *N*, then a completion condition is raised: *no data*.
- 7) If *FI* indicates a descriptor field whose value is the initially undefined value created when the descriptor was created, then an exception condition is raised: *FDW-specific condition — invalid descriptor field identifier*.
- 8) Let *IDA* be the foreign-data wrapper item descriptor area of *D* specified by *RN*.
- 9) If *TYPE* is 'HEADER', then header information from the descriptor area *D* is retrieved as follows.

NOTE 75 — In the row of Table 32, “Ability to retrieve foreign-data wrapper descriptor fields”, that contains *FI*, let *MBR* be the value in the column that contains the descriptor type of *D*. If *MBR* is 'No', then the effect on the retrieved value is implementation-dependent.

Case:

- a) If *FI* indicates COUNT, then the value retrieved is *N*.
- b) If *FI* indicates an implementation-defined descriptor header field, then the value retrieved is the value of the implementation-defined descriptor header field identified by *FI*.
- c) Otherwise, if *FI* indicates a descriptor header field defined in Table 30, “Codes used for foreign-data wrapper descriptor fields”, then the value retrieved is the value of the descriptor header field identified by *FI*.

10) If *TYPE* is 'ITEM', then item information from the descriptor area *D* is retrieved as follows.

NOTE 76 — Let *MBR* be the value of the May Be Retrieved column in the row of Table 32, “Ability to retrieve foreign-data wrapper descriptor fields”, that contains *FI* and the column that contains the descriptor type *D*. If *MBR* is 'No', then the effect on the retrieved value is implementation-dependent.

Case:

- a) If *FI* indicates an implementation-defined descriptor item field, then the value retrieved is the value of the implementation-defined descriptor item field of *IDA* identified by *FI*.
- b) Otherwise, if *FI* indicates a descriptor item field defined in Table 30, “Codes used for foreign-data wrapper descriptor fields”, then the value retrieved is the value of the descriptor item field identified by *FI*.

11) Let *V* be the value retrieved.

12) If *FI* indicates a descriptor field whose row in Table 4, “Fields in foreign-data wrapper descriptor areas”, contains a Data Type that is not CHARACTER VARYING, then Value is set to *V* and no further rules of this Subclause are applied.

13) Let *BL* be the value of BufferLength.

14) If *FI* indicates a descriptor field whose row in Table 4, “Fields in foreign-data wrapper descriptor areas”, contains a Data Type that is CHARACTER VARYING, then the General Rules of Subclause 21.7, “Character string retrieval”, are applied with Value, *V*, *BL*, and StringLength as *TARGET*, *VALUE*, *TARGET OCTET LENGTH*, and *RETURNED OCTET LENGTH*, respectively.

## Conformance Rules

- 1) Without Feature M030, “SQL-server foreign data support”, a conforming foreign-data wrapper shall not contain an invocation of a <foreign-data wrapper interface routine> that contains a <foreign-data wrapper interface routine name> that contains GetDescriptor.



### 22.4.6 GetDistinct

## Function

Determine whether the supplied query specifies DISTINCT.

## Definition

```
GetDistinct (
 RequestHandle IN INTEGER,
 IsDistinct OUT SMALLINT)
RETURNS SMALLINT
```

## General Rules

- 1) Let *RH* be the value of RequestHandle.
- 2) If *RH* does not identify an allocated request description, then an exception condition is raised: *FDW-specific condition — invalid handle*.
- 3) Let *Q* be the query associated with *RH*.
- 4) Case:
  - a) If the <select list> of *Q* specifies a <set quantifier> that specifies DISTINCT, then IsDistinct is set to 1 (one).
  - b) Otherwise, IsDistinct is set to 0 (zero).

## Conformance Rules

- 1) Without Feature M030, “SQL-server foreign data support”, a conforming foreign-data wrapper shall not contain an invocation of a <foreign-data wrapper interface routine> that contains a <foreign-data wrapper interface routine name> that contains GetDistinct.

### 22.4.7 GetNumBoolVE

#### Function

Get the number of <boolean value expression>s simply contained in the <where clause> of a query.

#### Definition

```
GetNumBoolVE (
 RequestHandle IN INTEGER,
 NumberOfBoolVEs OUT INTEGER)
RETURNS SMALLINT
```

#### General Rules

- 1) Let *RH* be the value of RequestHandle.
- 2) If *RH* does not identify an allocated request description, then an exception condition is raised: *FDW-specific condition — invalid handle*.
- 3) Let *Q* be the query associated with *RH*.
- 4) NumberOfBoolVEs is set to the number of <boolean value expression> elements simply contained in the <where clause> of *Q*.

#### Conformance Rules

- 1) Without Feature M030, “SQL-server foreign data support”, a conforming foreign-data wrapper shall not contain an invocation of a <foreign-data wrapper interface routine> that contains a <foreign-data wrapper interface routine name> that contains GetNumBoolVE.

### 22.4.8 GetNumChildren

#### Function

Get the number of <value expression>s simply contained in the containing <value expression>.

#### Definition

```
GetNumChildren (
 ValueExpressionHandle IN INTEGER,
 NumberOfChildren OUT SMALLINT)
RETURNS SMALLINT
```

#### General Rules

- 1) Let *VEH* be the value of ValueExpressionHandle.
- 2) If *VEH* does not identify an allocated <value expression> description, then an exception condition is raised: *FDW-specific condition — invalid handle*.
- 3) NumberOfChildren is set to the number of <value expression>s simply contained in the <value expression> to which *VEH* refers.

#### Conformance Rules

- 1) Without Feature M030, “SQL-server foreign data support”, a conforming foreign-data wrapper shall not contain an invocation of a <foreign-data wrapper interface routine> that contains a <foreign-data wrapper interface routine name> that contains GetNumChildren.

### 22.4.9 GetNumOrderByElems

#### Function

Get the number of <value expression>s that are used to order the rows of the result of the query identified by the request handle provided.

#### Definition

```
GetNumOrderByElems (
 RequestHandle IN INTEGER,
 NumberOfOrderByElems OUT SMALLINT)
RETURNS SMALLINT
```

#### General Rules

- 1) Let *RH* be the value of RequestHandle.
- 2) If *RH* does not identify an allocated request description, then an exception condition is raised: *FDW-specific condition — invalid handle*.
- 3) NumberOfOrderByElems is set to the number of <value expression>s required to order the rows of the result of the query associated with *RH*.

#### Conformance Rules

- 1) Without Feature M030, “SQL-server foreign data support”, a conforming foreign-data wrapper shall not contain an invocation of a <foreign-data wrapper interface routine> that contains a <foreign-data wrapper interface routine name> that contains GetNumOrderByElems.

### 22.4.10 GetNumRoutMapOpts

#### Function

Get the number of generic options of a routine mapping.

#### Definition

```
GetNumRoutMapOpts (
 RoutineMappingHandle IN INTEGER,
 OptionCount OUT INTEGER)
RETURNS SMALLINT
```

#### General Rules

- 1) Let *RH* be the value of RoutineMappingHandle.
- 2) If *RH* does not identify an allocated routine mapping description, then an exception condition is raised: *FDW-specific condition — invalid handle*.
- 3) OptionCount is set to the number of generic options of the routine mapping described by *RH*.

#### Conformance Rules

- 1) Without Feature M030, “SQL-server foreign data support”, a conforming foreign-data wrapper shall not contain an invocation of a <foreign-data wrapper interface routine> that contains a <foreign-data wrapper interface routine name> that contains GetNumRoutMapOpts.

### 22.4.11 GetNumSelectElems

#### Function

Get the number of <value expressions>s in the <select list> of a query.

#### Definition

```
GetNumSelectElems (
 RequestHandle IN INTEGER,
 NumberOfSelectListElements OUT SMALLINT)
RETURNS SMALLINT
```

#### General Rules

- 1) Let *RH* be the value of RequestHandle.
- 2) If *RH* does not identify an allocated request description, then an exception condition is raised: *FDW-specific condition — invalid handle*.
- 3) Let *Q* be the query associated with *RH*.
- 4) NumberOfSelectListElements is set to the number of <value expression> elements simply contained in the <select list> of *Q*.

#### Conformance Rules

- 1) Without Feature M030, “SQL-server foreign data support”, a conforming foreign-data wrapper shall not contain an invocation of a <foreign-data wrapper interface routine> that contains a <foreign-data wrapper interface routine name> that contains GetNumSelectElems.

### 22.4.12 GetNumServerOpts

#### Function

Get the number of generic options associated with the foreign server.

#### Definition

```
GetNumServerOpts (
 ServerHandle IN INTEGER ,
 OptionCount OUT INTEGER)
RETURNS SMALLINT
```

#### General Rules

- 1) Let *SH* be the value of ServerHandle.
- 2) If *SH* does not identify an allocated foreign server description, then an exception condition is raised: *FDW-specific condition — invalid handle*.
- 3) OptionCount is set to the number of generic options associated with *SH*.

#### Conformance Rules

- 1) Without Feature M030, “SQL-server foreign data support”, a conforming foreign-data wrapper shall not contain an invocation of a <foreign-data wrapper interface routine> that contains a <foreign-data wrapper interface routine name> that contains GetNumServerOpts.

### 22.4.13 GetNumTableColOpts

#### Function

Get the number of generic options of a column of a foreign table.

#### Definition

```
GetNumTableColOpts (
 TableReferenceHandle IN INTEGER,
 ColumnName IN CHARACTER (L),
 NameLength IN SMALLINT,
 OptionCount OUT INTEGER)
RETURNS SMALLINT
```

where *L* and has a maximum value equal to the implementation-defined length of a variable-length character string.

#### General Rules

- 1) Let *TRH* be the value of TableReferenceHandle.
- 2) If *TRH* does not identify an allocated table reference description, then an exception condition is raised: *FDW-specific condition — invalid handle*.
- 3) Let *NL* be the value of NameLength.
- 4) Case:
  - a) If *NL* is not negative, then let *L* be *NL*.
  - b) Otherwise, an exception condition is raised: *FDW-specific condition — invalid string length or buffer length*.
- 5) Case:
  - a) If *L* is zero, then an exception condition is raised: *FDW-specific condition — invalid string length or buffer length*.
  - b) Otherwise, let *N* be the number of whole characters in the first *L* octets of ColumnName and let *NO* be the number of octets occupied by those *N* characters.
 

Case:

    - i) If *NO* ≠ *L*, then an exception condition is raised: *FDW-specific condition — invalid column name*.
    - ii) Otherwise, let *CN* be the first *L* octets of ColumnName and let *TCN* be the value of
 

```
TRIM (BOTH ' ' FROM 'CN')
```



**22.4 Foreign-data wrapper interface SQL-server routines**

- 6) Let *NC* be the number of columns of the foreign table referenced by *TRH*.
- 7) Case:
  - a) If *TCN* is not equivalent to the name of a column of the foreign table referenced by *TRH*, then an exception condition is raised: *FDW-specific condition — column name not found*.
  - b) Otherwise, *OptionCount* is set to the number of generic options of the column of the foreign table referenced by *TRH* whose name is *TCN*.

**Conformance Rules**

- 1) Without Feature M030, “SQL-server foreign data support”, a conforming foreign-data wrapper shall not contain an invocation of a <foreign-data wrapper interface routine> that contains a <foreign-data wrapper interface routine name> that contains *GetNumTableColOpts*.

### 22.4.14 GetNumTableOpts

#### Function

Get the number of generic options of a foreign table.

#### Definition

```
GetNumTableOpts (
 TableReferenceHandle IN INTEGER,
 OptionCount OUT INTEGER)
RETURNS SMALLINT
```

#### General Rules

- 1) Let *TRH* be the value of TableReferenceHandle.
- 2) If *TRH* does not identify an allocated table reference description, then an exception condition is raised: *FDW-specific condition — invalid handle*.
- 3) OptionCount is set to the number of generic options of the foreign table referenced by *TRH*.

#### Conformance Rules

- 1) Without Feature M030, “SQL-server foreign data support”, a conforming foreign-data wrapper shall not contain an invocation of a <foreign-data wrapper interface routine> that contains a <foreign-data wrapper interface routine name> that contains GetNumTableOpts.

### 22.4.15 GetNumTableRefElems

#### Function

Get the number of <table reference>s contained in the <from clause> of a query.

#### Definition

```
GetNumTableRefElems (
 RequestHandle IN INTEGER,
 NumberOfTableReferences OUT SMALLINT)
RETURNS SMALLINT
```

#### General Rules

- 1) Let *RH* be the value of RequestHandle.
- 2) If *RH* does not identify an allocated request description, then an exception condition is raised: *FDW-specific condition — invalid handle*.
- 3) Let *Q* be the query associated with *RH*.
- 4) NumberOfTableReferenceElements is set to the number of <table reference> elements simply contained in the <from clause> of *Q*.

#### Conformance Rules

- 1) Without Feature M030, “SQL-server foreign data support”, a conforming foreign-data wrapper shall not contain an invocation of a <foreign-data wrapper interface routine> that contains a <foreign-data wrapper interface routine name> that contains GetNumTableRefElems.

### 22.4.16 GetNumUserOpts

#### Function

Get the number of generic options of a user mapping.

#### Definition

```
GetNumUserOpts (
 UserHandle IN INTEGER,
 OptionCount OUT INTEGER)
RETURNS SMALLINT
```

#### General Rules

- 1) Let *UH* be the value of UserHandle.
- 2) If *UH* does not identify an allocated user mapping description, then an exception condition is raised: *FDW-specific condition — invalid handle*.
- 3) OptionCount is set to the number of generic options of the user mapping described by *UH*.

#### Conformance Rules

- 1) Without Feature M030, “SQL-server foreign data support”, a conforming foreign-data wrapper shall not contain an invocation of a <foreign-data wrapper interface routine> that contains a <foreign-data wrapper interface routine name> that contains GetNumUserOpts.

### 22.4.17 GetNumWrapperOpts

#### Function

Get the number of generic options of a foreign-data wrapper.

#### Definition

```
GetNumWrapperOpts (
 WrapperHandle IN INTEGER,
 OptionCount OUT INTEGER)
RETURNS SMALLINT
```

#### General Rules

- 1) Let *WH* be the value of WrapperHandle.
- 2) If *WH* does not identify an allocated foreign-data wrapper description, then an exception condition is raised: *FDW-specific condition — invalid handle*.
- 3) OptionCount is set to the number of generic options of the foreign-data wrapper described by *WH*.

#### Conformance Rules

- 1) Without Feature M030, “SQL-server foreign data support”, a conforming foreign-data wrapper shall not contain an invocation of a <foreign-data wrapper interface routine> that contains a <foreign-data wrapper interface routine name> that contains GetNumWrapperOpts.

### 22.4.18 GetOrderByElem

#### Function

Get the handle for a <value expression> used to order the result of a query.

#### Definition

```
GetOrderByElem (
 RequestHandle IN INTEGER,
 OrderByNumber IN SMALLINT,
 ValueExpressionHandle OUT INTEGER,
 OrderingSpec OUT SMALLINT)
RETURNS SMALLINT
```

#### General Rules

- 1) Let *RH* be the value of RequestHandle.
- 2) If *RH* does not identify an allocated request description, then an exception condition is raised: *FDW-specific condition — invalid handle*.
- 3) Let *ON* be the value of OrderByNumber.
- 4) If *ON* is less than 1 (one), then an exception condition is raised: *FDW-specific condition — invalid option index*.
- 5) Let *Q* be the query associated with *RH*.
- 6) Let *N* be the number of <value expression>s required to order the result of *Q*.
- 7) If *ON* is greater than *N*, then a completion condition is raised: *no data*, and no further rules of this Subclause are applied.
- 8) Let *VEH* be the value expression handle associated with the *ON*-th <value expression> associated with *Q*.
- 9) ValueExpressionHandle is set to *VEH*.
- 10) Let *OS* be the <ordering specification> associated with *VEH*.

Case:

- a) If *OS* specifies ASC, then set OrderingSpec to -1 (one).
- b) Otherwise, set OrderingSpec to 1 (one).

#### Conformance Rules

- 1) Without Feature M030, “SQL-server foreign data support”, a conforming foreign-data wrapper shall not contain an invocation of a <foreign-data wrapper interface routine> that contains a <foreign-data wrapper interface routine name> that contains GetOrderByElem.

### 22.4.19 GetRoutMapOpt

#### Function

Get the name and value of a specified generic option associated with a given routine mapping, given the option number.

#### Definition

```
GetRoutMapOpt (
 RoutineMappingHandle IN INTEGER ,
 OptionNumber IN INTEGER ,
 OptionName OUT CHARACTER (L1) ,
 BufferLength1 IN SMALLINT ,
 StringLength1 OUT SMALLINT ,
 OptionValue OUT CHARACTER (L2) ,
 BufferLength2 IN SMALLINT ,
 StringLength2 OUT SMALLINT)
RETURNS SMALLINT
```

where each of *L1* and *L2* have a value equal to the implementation-defined maximum length of a variable-length character string.

#### General Rules

- 1) Let *RH* be the value of RoutineMappingHandle.
- 2) If *RH* does not identify an allocated routine mapping description, then an exception condition is raised: *FDW-specific condition — invalid handle*.
- 3) Let *ON* be the value of OptionNumber.
- 4) Let *N* be the number of generic options associated with *RH*.
- 5) If *ON* is less than 1 (one), then an exception condition is raised: *FDW-specific condition — invalid option index*.
- 6) If *ON* is greater than *N*, then a completion condition is raised: *no data* and no further rules of this Subclause are applied.
- 7) Information from the *ON*-th generic option associated with *RH* is retrieved.
  - a) Let *NAME* be the name of the generic option.
  - b) The General Rules of [Subclause 21.7](#), “Character string retrieval”, are applied to OptionName, *NAME*, BufferLength1, and StringLength1 as *TARGET*, *VALUE*, *TARGET OCTET LENGTH*, and *RETURNED OCTET LENGTH*, respectively.
  - c) Let *OPTIONVALUE* be the value of the generic option.

**22.4 Foreign-data wrapper interface SQL-server routines**

- d) The General Rules of Subclause 21.7, “Character string retrieval”, are applied to OptionValue, *OPTIONVALUE*, BufferLength2, and StringLength2 as *TARGET*, *VALUE*, *TARGET OCTET LENGTH*, and *RETURNED OCTET LENGTH*, respectively.

**Conformance Rules**

- 1) Without Feature M030, “SQL-server foreign data support”, a conforming foreign-data wrapper shall not contain an invocation of a <foreign-data wrapper interface routine> that contains a <foreign-data wrapper interface routine name> that contains GetRoutMapOpt.



### 22.4.20 GetRoutMapOptName

#### Function

Get the value of a generic option associated with a given routine mapping, given the option name.

#### Definition

```
GetRoutMapOptName (
 RoutineMappingHandle IN INTEGER,
 OptionName IN CHARACTER (L1),
 BufferLength1 IN SMALLINT,
 OptionValue OUT CHARACTER (L2),
 BufferLength2 IN SMALLINT,
 StringLength2 OUT SMALLINT)
RETURNS SMALLINT
```

where each of *L1* and *L2* have a value equal to the implementation-defined maximum length of a variable-length character string.

#### General Rules

- 1) Let *RH* be the value of RoutineMappingHandle.
- 2) If *RH* does not identify an allocated routine mapping description, then an exception condition is raised: *FDW-specific condition — invalid handle*.
- 3) Let *NL* be the value of BufferLength1.
- 4) Case:
  - a) If *NL* is not negative, then let *L* be *NL*.
  - b) Otherwise, an exception condition is raised: *FDW-specific condition — invalid string length or buffer length*.
- 5) Case:
  - a) If *L* is zero, then an exception condition is raised: *FDW-specific condition — invalid string length or buffer length*.
  - b) Otherwise, let *N* be the number of whole characters in the first *L* octets of OptionName and let *NO* be the number of octets occupied by those *N* characters.
 

Case:

    - i) If *NO* ≠ *L*, then an exception condition is raised: *FDW-specific condition — invalid option name*.
    - ii) Otherwise, let *ON* be the first *N* characters of OptionName and let *TON* be the value of:  
 TRIM ( BOTH ' ' FROM 'ON' )
- 6) Case:

**22.4 Foreign-data wrapper interface SQL-server routines**

- a) If *TON* is equivalent to the name of a generic option associated with *RH*, then:
  - i) Let *OPTIONVALUE* be the value of the generic option associated with *RH* whose name is equivalent to *TON*.
  - ii) The General Rules of [Subclause 21.7](#), “Character string retrieval”, are applied to OptionValue, *OPTIONVALUE*, BufferLength2, and StringLength2 as *TARGET*, *VALUE*, *TARGET OCTET LENGTH*, and *RETURNED OCTET LENGTH*, respectively.
- b) Otherwise, an exception condition is raised: *FDW-specific condition — option name not found*.

**Conformance Rules**

- 1) Without Feature M030, “SQL-server foreign data support”, a conforming foreign-data wrapper shall not contain an invocation of a <foreign-data wrapper interface routine> that contains a <foreign-data wrapper interface routine name> that contains GetRoutMapOptName.

### 22.4.21 GetRoutineMapping

#### Function

Get the routine mapping handle for an allocated routine mapping description.

#### Definition

```
GetRoutineMapping (
 ValueExpressionHandle IN INTEGER,
 RoutineMappingHandle OUT INTEGER)
RETURNS SMALLINT
```

#### General Rules

- 1) Let *VEH* be the value of ValueExpressionHandle.
- 2) If *VEH* does not identify an allocated <value expression> description, then an exception condition is raised: *FDW-specific condition — invalid handle*.
- 3) Let *RMH* be the handle for the allocated routine mapping description that is associated with *VEH*.
- 4) RoutineMappingHandle is set to *RMH*.

#### Conformance Rules

- 1) Without Feature M030, “SQL-server foreign data support”, a conforming foreign-data wrapper shall not contain an invocation of a <foreign-data wrapper interface routine> that contains a <foreign-data wrapper interface routine name> that contains GetRoutineMapping.

### 22.4.22 GetSelectElem

#### Function

Get the handle of a <value expression> simply contained in the <select list> of a query.

#### Definition

```
GetSelectElem (
 RequestHandle IN INTEGER,
 SelectListElementNumber IN SMALLINT,
 ValueExpressionHandle OUT INTEGER)
RETURNS SMALLINT
```

#### General Rules

- 1) Let *RH* be the value of RequestHandle.
- 2) If *RH* does not identify an allocated request description, then an exception condition is raised: *FDW-specific condition — invalid handle*.
- 3) Let *SLEN* be the value of SelectListElementNumber.
- 4) If *SLEN* is less than 1 (one), then an exception condition is raised: *FDW-specific condition — invalid option index*.
- 5) Let *Q* be the query associated with *RH*.
- 6) Let *N* be the number of <value expression> elements simply contained in the <select list> of *Q*.
- 7) If *SLEN* is greater than *N*, then a completion condition is raised: *no data*, and no further rules of this Subclause are applied.
- 8) ValueExpressionHandle is set to the value expression handle associated with the *SLEN*-th <value expression> associated with *Q*.

#### Conformance Rules

- 1) Without Feature M030, “SQL-server foreign data support”, a conforming foreign-data wrapper shall not contain an invocation of a <foreign-data wrapper interface routine> that contains a <foreign-data wrapper interface routine name> that contains GetSelectElem.

### 22.4.23 GetSelectElemType

#### Function

Get the kind of a <value expression> in the <select list> of a query.

#### Definition

```
GetSelectElemType (
 ValueExpressionHandle IN INTEGER,
 ValueExpressionType OUT SMALLINT)
RETURNS SMALLINT
```

#### General Rules

- 1) Let *VEH* be the value of ValueExpressionHandle.
- 2) If *VEH* does not identify an allocated <value expression> description, then an exception condition is raised: *FDW-specific condition — invalid handle*.
- 3) ValueExpressionType is set to the value of ValueExpressionKind that would be returned by invocation of GetValueExpKind( ) with *VEH* as the ValueExpressionHandle parameter.

#### Conformance Rules

- 1) Without Feature M030, “SQL-server foreign data support”, a conforming foreign-data wrapper shall not contain an invocation of a <foreign-data wrapper interface routine> that contains a <foreign-data wrapper interface routine name> that contains GetSelectElemType.

### 22.4.24 GetServerName

#### Function

Get the name of the foreign server associated with the provided server handle.

#### Definition

```
GetServerName (
 ServerHandle IN INTEGER,
 ServerName OUT CHARACTER (L),
 BufferLength IN SMALLINT,
 StringLength OUT SMALLINT)
RETURNS SMALLINT
```

where  $L$  has a maximum value equal to  $(2n+1)$ , where  $n$  is the implementation-defined length of an <identifier>.

NOTE 77 — The length  $(2n+1)$  supports the syntax of <foreign server name>, which is “<identifier><period><identifier>”.

#### General Rules

- 1) Let  $SH$  be the value of ServerHandle.
- 2) If  $SH$  does not identify an allocated foreign server description, then an exception condition is raised: *FDW-specific condition — invalid handle*.
- 3) Let  $SN$  be the server name associated with  $SH$ .
- 4) Let  $BL$  be the value of BufferLength.
- 5) The General Rules of Subclause 21.7, “Character string retrieval”, are applied to ServerName,  $SN$ ,  $BL$ , and StringLength as *TARGET*, *VALUE*, *TARGET OCTET LENGTH*, and *RETURNED OCTET LENGTH*, respectively.

#### Conformance Rules

- 1) Without Feature M030, “SQL-server foreign data support”, a conforming foreign-data wrapper shall not contain an invocation of a <foreign-data wrapper interface routine> that contains a <foreign-data wrapper interface routine name> that contains GetServerName.

### 22.4.25 GetServerOpt

## Function

Get the value of a generic option associated with a foreign server.

## Definition

```
GetServerOpt (
 ServerHandle IN INTEGER,
 OptionNumber IN INTEGER,
 OptionName OUT CHARACTER(L1),
 BufferLength1 IN SMALLINT,
 StringLength1 OUT SMALLINT,
 OptionValue OUT CHARACTER(L2),
 BufferLength2 IN SMALLINT,
 StringLength2 OUT SMALLINT)
RETURNS SMALLINT
```

where each of *L1* and *L2* has a maximum value of equal to the implementation-defined length of a variable-length character string.

## General Rules

- 1) Let *SH* be the value of *ServerHandle*.
- 2) If *SH* does not identify an allocated foreign server description, then an exception condition is raised: *FDW-specific condition — invalid handle*.
- 3) Let *ON* be the value of *OptionNumber*.
- 4) Let *N* be the number of generic options associated with *SH*.
- 5) If *ON* is less than 1 (one), then an exception condition is raised: *FDW-specific condition — invalid option index*.
- 6) If *ON* is greater than *N*, then a completion condition is raised: *no data*, and no further rules of this Subclause are applied.
- 7) Information from the *ON*-th generic option associated with the *SH* is retrieved.
  - a) Let *NAME* be the name of the generic option.
  - b) The General Rules of [Subclause 21.7, “Character string retrieval”](#), are applied to *OptionName*, *NAME*, *BufferLength1*, and *StringLength1* as *TARGET*, *VALUE*, *TARGET OCTET LENGTH*, and *RETURNED OCTET LENGTH*, respectively.
  - c) Let *OPTIONVALUE* be the value of the generic option.
  - d) The General Rules of [Subclause 21.7, “Character string retrieval”](#), are applied to *OptionValue*, *OPTIONVALUE*, *BufferLength2*, and *StringLength2* as *TARGET*, *VALUE*, *TARGET OCTET LENGTH*, and *RETURNED OCTET LENGTH*, respectively.

## Conformance Rules

- 1) Without Feature M030, “SQL-server foreign data support”, a conforming foreign-data wrapper shall not contain an invocation of a <foreign-data wrapper interface routine> that contains a <foreign-data wrapper interface routine name> that contains GetServerOpt.



### 22.4.26 GetServerOptByName

#### Function

Get the value of a generic option associated with a foreign server.

#### Definition

```
GetServerOptByName (
 ServerHandle IN INTEGER,
 OptionName IN CHARACTER (L1),
 BufferLength1 IN SMALLINT,
 OptionValue OUT CHARACTER (L2),
 BufferLength2 IN SMALLINT,
 StringLength2 OUT SMALLINT)
RETURNS SMALLINT
```

where each of *L1* and *L2* has a maximum value of equal to the implementation-defined length of a variable-length character string.

#### General Rules

- 1) Let *SH* be the value of ServerHandle.
- 2) If *SH* does not identify an allocated foreign server description, then an exception condition is raised: *FDW-specific condition — invalid handle*.
- 3) Let *BL* be the value of Bufferlength1.
- 4) Case:
  - a) If *BL* is not positive, then an exception condition is raised: *FDW-specific condition — invalid string length or buffer length*.
  - b) Otherwise, let *L* be *BL*, let *N* be the number of whole characters in the first *L* octets of OptionName and let *NO* be the number of octets occupied by those *N* characters.
 

Case:

    - i) If *NO* ≠ *L*, then an exception condition is raised: *FDW-specific condition — invalid option name*.
    - ii) Otherwise, let *ON* be the first *L* octets of OptionName and let *TON* be the value of:  
 TRIM ( BOTH ' ' FROM 'ON' )
- 5) Let *N* be the number of generic options associated with *SH*.
- 6) Case:
  - a) If *TON* is equivalent to the name of a generic option associated with *SH*, then:
    - i) Let *OPTIONVALUE* be the value of the generic option associated with *SH* whose name is equivalent to *TON*.

**22.4 Foreign-data wrapper interface SQL-server routines**

- ii) The General Rules of Subclause 21.7, “Character string retrieval”, are applied to OptionValue, *OPTIONVALUE*, BufferLength2, and StringLength2 as *TARGET*, *VALUE*, *TARGET OCTET LENGTH*, and *RETURNED OCTET LENGTH*, respectively.
- b) Otherwise, an exception condition is raised: *FDW-specific condition — option name not found*.

**Conformance Rules**

- 1) Without Feature M030, “SQL-server foreign data support”, a conforming foreign-data wrapper shall not contain an invocation of a <foreign-data wrapper interface routine> that contains a <foreign-data wrapper interface routine name> that contains GetServerOptByName.

### 22.4.27 GetServerType

#### Function

Get the type of a foreign server.

#### Definition

```
GetServerType (
 ServerHandle IN INTEGER,
 ServerType OUT CHARACTER(L),
 BufferLength IN SMALLINT,
 StringLength OUT SMALLINT)
RETURNS SMALLINT
```

where *L* has a maximum value of equal to the implementation-defined length of a variable-length character string.

#### General Rules

- 1) Let *SH* be the value of *ServerHandle*.
- 2) If *SH* does not identify an allocated foreign server description, then an exception condition is raised: *FDW-specific condition — invalid handle*.
- 3) Let *ST* be the server type associated with *SH*.
- 4) Let *BL* be the value of *BufferLength*.
- 5) The General Rules of [Subclause 21.7, “Character string retrieval”](#), are applied to *ServerType*, *ST*, *BL*, and *StringLength* as *TARGET*, *VALUE*, *TARGET OCTET LENGTH*, and *RETURNED OCTET LENGTH*, respectively.

#### Conformance Rules

- 1) Without Feature M030, “SQL-server foreign data support”, a conforming foreign-data wrapper shall not contain an invocation of a <foreign-data wrapper interface routine> that contains a <foreign-data wrapper interface routine name> that contains *GetServerType*.

### 22.4.28 GetServerVersion

#### Function

Get the version of a foreign server.

#### Definition

```
GetServerVersion (
 ServerHandle IN INTEGER ,
 ServerVersion OUT CHARACTER(L) ,
 BufferLength IN SMALLINT ,
 StringLength OUT SMALLINT)
RETURNS SMALLINT
```

where *L* has a maximum value of equal to the implementation-defined length of a variable-length character string.

#### General Rules

- 1) Let *SH* be the value of ServerHandle.
- 2) If *SH* does not identify an allocated foreign server description, then an exception condition is raised: *FDW-specific condition — invalid handle*.
- 3) Let *SV* be the server version associated with *SH*.
- 4) Let *BL* be the value of BufferLength.
- 5) The General Rules of [Subclause 21.7, “Character string retrieval”](#), are applied to ServerVersion, *SV*, *BL*, and StringLength as *TARGET*, *VALUE*, *TARGET OCTET LENGTH*, and *RETURNED OCTET LENGTH*, respectively.

#### Conformance Rules

- 1) Without Feature M030, “SQL-server foreign data support”, a conforming foreign-data wrapper shall not contain an invocation of a <foreign-data wrapper interface routine> that contains a <foreign-data wrapper interface routine name> that contains GetServerVersion.

### 22.4.29 GetSQLString

#### Function

Get a character string representation of the query that is associated with a given request handle.

#### Definition

```
GetSQLString (
 RequestHandle IN INTEGER,
 StringFormat IN INTEGER,
 SQLString OUT CHARACTER VARYING(L),
 BufferLength IN INTEGER,
 StringLength OUT INTEGER)
RETURNS SMALLINT
```

where  $L$  is greater than or equal to the `StringLength` value returned, with a maximum value equal to the implementation-defined maximum length of a variable-length character string.

#### General Rules

- 1) Let  $RH$  be the value of `RequestHandle`.
- 2) If  $RH$  does not identify an allocated request description, then an exception condition is raised: *FDW-specific condition — invalid handle*.
- 3) Let  $Q$  be the query associated with  $RH$ .
- 4) Let  $SF$  be the value of `StringFormat`.
- 5) If  $SF$  does not identify a value that is equal to any value in Table 35, “Codes used for the format of the character string transmitted by `GetSQLString()`”, then an exception condition is raised: *FDW-specific condition — invalid string format*.
- 6) Case:
  - a) If  $SF$  identifies an implementation-defined value, then let  $QueryString$  be the implementation-defined character string representation of  $Q$ .
  - b) Otherwise, let  $QueryString$  be a character string conforming to the Format and Syntax Rules of Subclause 14.4, “<SQL procedure statement>”.
- 7) The General Rules of Subclause 21.7, “Character string retrieval”, are applied to `SQLString`,  $QueryString$ , `BufferLength`, and `StringLength` as *TARGET*, *VALUE*, *TARGET OCTET LENGTH*, and *RETURNED OCTET LENGTH*, respectively.

## Conformance Rules

- 1) Without Feature M006, “GetSQLString routine”, a conforming foreign-data wrapper shall not contain an invocation of a <foreign-data wrapper interface routine> that contains a <foreign-data wrapper interface routine name> that contains GetSQLString.

### 22.4.30 GetTableColOpt

## Function

Get the name and value of a generic option associated with a column of the foreign table reference by the supplied table reference handle, given an option number.

## Definition

```
GetTableColOpt (
 TableReferenceHandle IN INTEGER,
 ColumnName IN CHARACTER (L),
 NameLength IN SMALLINT,
 OptionNumber IN INTEGER,
 OptionName OUT CHARACTER (L1),
 BufferLength1 IN SMALLINT,
 StringLength1 OUT SMALLINT,
 OptionValue OUT CHARACTER (L2),
 BufferLength2 IN SMALLINT,
 StringLength2 OUT SMALLINT)
RETURNS SMALLINT
```

where each of *L*, *L1*, and *L2* has a maximum value equal to the implementation-defined length of a variable-length character string.

## General Rules

- 1) Let *TRH* be the value of TableReferenceHandle.
- 2) If *TRH* does not identify an allocated table reference description, then an exception condition is raised: *FDW-specific condition — invalid handle*.
- 3) Let *NL* be the value of NameLength.
- 4) Case:
  - a) If *NL* is not positive, then an exception condition is raised: *FDW-specific condition — invalid string length or buffer length*.
  - b) Otherwise, let *L* be *NL*, let *N* be the number of whole characters in the first *L* octets of ColumnName, and let *NO* be the number of octets occupied by those *N* characters.
 

Case:

    - i) If *NO* ≠ *L*, then an exception condition is raised: *FDW-specific condition — invalid column name*.
    - ii) Otherwise, let *CN* be the first *L* octets of ColumnName and let *TCN* be the value of `TRIM ( BOTH ' ' FROM 'CN' )`
- 5) Case:

## 22.4 Foreign-data wrapper interface SQL-server routines

- a) If *TCN* is not equivalent to the name of a column of the foreign table referenced by *TRH*, then an exception condition is raised: *FDW-specific condition — column name not found*.
- b) Otherwise:
  - i) Let *ON* be the value of *OptionNumber*.
  - ii) Let *N* be the number of generic options associated with the column identified by *TCN*.
  - iii) If *ON* is less than 1 (one), then an exception condition is raised: *FDW-specific condition — invalid option index*.
  - iv) If *ON* is greater than *N*, then a completion condition is raised: *no data* and no further rules of this Subclause are applied.
  - v) Let *NAME* be the name of the *ON*-th generic option associated with the column identified by *TCN*.
  - vi) The General Rules of Subclause 21.7, “Character string retrieval”, are applied to *OptionName*, *NAME*, *BufferLength1*, and *StringLength1* as *TARGET*, *VALUE*, *TARGET OCTET LENGTH*, and *RETURNED OCTET LENGTH*, respectively.
  - vii) Let *VALUE* be the value of the *ON*-th generic option associated with the column identified by *TCN*.
  - viii) The General Rules of Subclause 21.7, “Character string retrieval”, are applied to *OptionValue*, *VALUE*, *BufferLength2*, and *StringLength2* as *TARGET*, *VALUE*, *TARGET OCTET LENGTH*, and *RETURNED OCTET LENGTH*, respectively.

## Conformance Rules

- 1) Without Feature M030, “SQL-server foreign data support”, a conforming foreign-data wrapper shall not contain an invocation of a <foreign-data wrapper interface routine> that contains a <foreign-data wrapper interface routine name> that contains *GetTableColOpt*.



### 22.4.31 GetTableColOptByName

#### Function

Get the value of a generic option associated with a column of the foreign table referenced by the specified table reference handle, given the option name.

#### Definition

```
GetTableColOptByName (
 TableReferenceHandle IN INTEGER,
 ColumnName IN CHARACTER (L),
 NameLength IN SMALLINT,
 OptionName IN CHARACTER (L1),
 BufferLength1 IN SMALLINT,
 OptionValue OUT CHARACTER (L2),
 BufferLength2 IN SMALLINT,
 StringLength2 OUT SMALLINT)
RETURNS SMALLINT
```

where each of *L*, *L1*, and *L2* has a maximum value equal to the implementation-defined length of a variable-length character string.

#### General Rules

- 1) Let *TRH* be the value of TableReferenceHandle.
- 2) If *TRH* does not identify an allocated table reference description, then an exception condition is raised: *FDW-specific condition — invalid handle*.
- 3) Let *NL* be the value of NameLength.
- 4) Case:
  - a) If *NL* is not positive, then an exception condition is raised: *FDW-specific condition — invalid string length or buffer length*.
  - b) Otherwise, let *L* be *NL*, let *N* be the number of whole characters in the first *L* octets of ColumnName, and let *NO* be the number of octets occupied by those *N* characters.
 

Case:

    - i) If  $NO \neq L$ , then an exception condition is raised: *FDW-specific condition — invalid column name*.
    - ii) Otherwise, let *CN* be the first *L* octets of ColumnName and let *TCN* be the value of `TRIM ( BOTH ' ' FROM 'CN' )`
- 5) Case:

## 22.4 Foreign-data wrapper interface SQL-server routines

- a) If *TCN* is not equivalent to the name of a column of the foreign table referenced by *TRH*, then an exception condition is raised: *FDW-specific condition — column name not found*.
- b) Otherwise:
  - i) Let *BL* be the value of *BufferLength1*.
  - ii) Case:
    - 1) If *BL* is not positive, then an exception condition is raised: *FDW-specific condition — invalid string length or buffer length*.
    - 2) Otherwise, let *BLI* be *BL*, let *BN* be the number of whole characters in the first *BLI* octets of *OptionName*, and let *BNO* be the number of octets occupied by those *BN* characters.
 

Case:

      - A) If  $BNO \neq BLI$ , then an exception condition is raised: *FDW-specific condition — invalid option name*.
      - B) Otherwise, let *ON* be the first *BLI* octets of *OptionName* and let *TON* be the value of `TRIM ( BOTH ' ' FROM 'ON' )`
  - iii) Case:
    - 1) If *TON* is not equivalent to the name of a generic option associated with *TRH*, then an exception condition is raised: *FDW-specific condition — option name not found*.
    - 2) Otherwise:
      - A) Let *VALUE* be the value of the generic option associated with *TRH* whose name is *TON*.
      - B) The General Rules of [Subclause 21.7](#), “Character string retrieval”, are applied to *OptionValue*, *VALUE*, *BufferLength2*, and *StringLength2* as *TARGET*, *VALUE*, *TARGET OCTET LENGTH*, and *RETURNED OCTET LENGTH*, respectively.

## Conformance Rules

- 1) Without Feature M030, “SQL-server foreign data support”, a conforming foreign-data wrapper shall not contain an invocation of a <foreign-data wrapper interface routine> that contains a <foreign-data wrapper interface routine name> that contains `GetTableColOptByName`.

### 22.4.32 GetTableOpt

#### Function

Get the name and value of a generic option associated with the foreign table identified by the given table reference handle, given an option number.

#### Definition

```
GetTableOpt (
 TableReferenceHandle IN INTEGER,
 OptionNumber IN INTEGER,
 OptionName OUT CHARACTER(L1),
 BufferLength1 IN SMALLINT,
 StringLength1 OUT SMALLINT,
 OptionValue OUT CHARACTER(L2),
 BufferLength2 IN SMALLINT,
 StringLength2 OUT SMALLINT)
RETURNS SMALLINT
```

where each of *L1* and *L2* has a maximum value equal to the implementation-defined length of a variable-length character string.

#### General Rules

- 1) Let *TRH* be the value of TableReferenceHandle.
- 2) If *TRH* does not identify an allocated table reference description, then an exception condition is raised: *FDW-specific condition — invalid handle*.
- 3) Let *ON* be the value of OptionNumber.
- 4) Let *N* be the number of generic options associated with *TRH*.
- 5) If *ON* is less than 1 (one), then an exception condition is raised: *FDW-specific condition — invalid option index*.
- 6) If *ON* is greater than *N*, then a completion condition is raised: *no data* and no further rules of this Subclause are applied.
- 7) Let *NAME* be the name of the *ON*-th generic option associated with *TRH*.
- 8) The General Rules of Subclause 21.7, “Character string retrieval”, are applied to OptionName, *NAME*, BufferLength1, and StringLength1 as *TARGET*, *VALUE*, *TARGET OCTET LENGTH*, and *RETURNED OCTET LENGTH*, respectively.
- 9) Let *VALUE* be the value of the *ON*-th generic option associated with *TRH*.
- 10) The General Rules of Subclause 21.7, “Character string retrieval”, are applied to OptionValue, *VALUE*, BufferLength2, and StringLength2 as *TARGET*, *VALUE*, *TARGET OCTET LENGTH*, and *RETURNED OCTET LENGTH*, respectively.

## Conformance Rules

- 1) Without Feature M030, “SQL-server foreign data support”, a conforming foreign-data wrapper shall not contain an invocation of a <foreign-data wrapper interface routine> that contains a <foreign-data wrapper interface routine name> that contains GetTableOpt.

### 22.4.33 GetTableOptByName

#### Function

Get the value of a generic option associated with the foreign table identified by the specified table reference handle, given the option name.

#### Definition

```
GetTableOptByName (
 TableReferenceHandle IN INTEGER,
 OptionName IN CHARACTER (L1),
 BufferLength1 IN SMALLINT,
 OptionValue OUT CHARACTER (L2),
 BufferLength2 IN SMALLINT,
 StringLength2 OUT SMALLINT)
RETURNS SMALLINT
```

where each of *L1* and *L2* has a maximum value equal to the implementation-defined length of a variable-length character string.

#### General Rules

- 1) Let *TRH* be the value of TableReferenceHandle.
- 2) If *TRH* does not identify an allocated table reference description, then an exception condition is raised: *FDW-specific condition — invalid handle*.
- 3) Let *NL* be the value of BufferLength1.
- 4) Case:
  - a) If *NL* is not positive, then an exception condition is raised: *FDW-specific condition — invalid string length or buffer length*.
  - b) Otherwise, let *L* be *NL*, let *N* be the number of whole characters in the first *L* octets of OptionName, and let *NO* be the number of octets occupied by those *N* characters.
 

Case:

    - i) If  $NO \neq L$ , then an exception condition is raised: *FDW-specific condition — invalid option name*.
    - ii) Otherwise, let *ON* be the first *L* octets of OptionName and let *TON* be the value of `TRIM ( BOTH ' ' FROM 'ON' )`
- 5) Case:
  - a) If *TON* is not equivalent to the name of a generic option associated with *TRH*, then an exception condition is raised: *FDW-specific condition — option name not found*.
  - b) Otherwise:

**22.4 Foreign-data wrapper interface SQL-server routines**

- i) Let *VALUE* be the value of the generic option associated with *TRH* whose name is *TON*.
- ii) The General Rules of Subclause 21.7, “Character string retrieval”, are applied to OptionValue, *VALUE*, BufferLength2, and StringLength2 as *TARGET*, *VALUE*, *TARGET OCTET LENGTH*, and *RETURNED OCTET LENGTH*, respectively.

**Conformance Rules**

- 1) Without Feature M030, “SQL-server foreign data support”, a conforming foreign-data wrapper shall not contain an invocation of a <foreign-data wrapper interface routine> that contains a <foreign-data wrapper interface routine name> that contains GetTableOptByName.

### 22.4.34 GetTableRefElem

## Function

Get a <table reference> element from the <from clause> of a query, given a request handle and a table reference element number.

## Definition

```
GetTableRefElem (
 RequestHandle IN INTEGER,
 TableReferenceElementNumber IN INTEGER,
 TableReferenceHandle OUT INTEGER)
RETURNS SMALLINT
```

## General Rules

- 1) Let *RH* be the value of RequestHandle.
- 2) If *RH* does not identify an allocated request description, then an exception condition is raised: *FDW-specific condition — invalid handle*.
- 3) Let *TREN* be the value of TableReferenceElementNumber.
- 4) If *TREN* is less than 1 (one), then an exception condition is raised: *FDW-specific condition — invalid option index*.
- 5) Let *Q* be the query associated with *RH*.
- 6) Let *N* be the number of <table reference> elements in the <from clause> of *Q*.
- 7) If *TREN* is greater than *N*, then a completion condition is raised: *no data*, and no further rules of this Subclause are applied.
- 8) TableReferenceHandle is set to the table reference handle associated with the *TREN*-th <table reference> associated with *Q*.

## Conformance Rules

- 1) Without Feature M030, “SQL-server foreign data support”, a conforming foreign-data wrapper shall not contain an invocation of a <foreign-data wrapper interface routine> that contains a <foreign-data wrapper interface routine name> that contains GetTableRefElem.

### 22.4.35 GetTableRefElemType

#### Function

Get the type of a <table reference>, given its table reference handle.

#### Definition

```
GetTableRefElemType (
 TableReferenceHandle IN INTEGER,
 TableReferenceType OUT SMALLINT)
RETURNS SMALLINT
```

#### General Rules

- 1) Let *TRH* be the value of TableReferenceHandle.
- 2) If *TRH* does not identify an allocated table reference description, then an exception condition is raised: *FDW-specific condition — invalid handle*.
- 3) Let *TRT* be the type of the <table reference> associated with *TRH*.
- 4) TableReferenceType is set to *TRT*.

#### Conformance Rules

- 1) Without Feature M030, “SQL-server foreign data support”, a conforming foreign-data wrapper shall not contain an invocation of a <foreign-data wrapper interface routine> that contains a <foreign-data wrapper interface routine name> that contains GetTableRefElemType.



### 22.4.36 GetTableRefTableName

#### Function

Get the table name of a TABLE\_NAME <table reference> identified by the given table reference handle.

#### Definition

```
GetTableRefTableName (
 TableReferenceHandle IN INTEGER,
 TableName OUT CHARACTER(L),
 BufferLength IN SMALLINT,
 StringLength OUT SMALLINT)
RETURNS SMALLINT
```

where *L* has a maximum value of equal to the implementation-defined length of a variable-length character string.

#### General Rules

- 1) Let *TRH* be the value of TableReferenceHandle.
- 2) If *TRH* does not identify an allocated table reference description, then an exception condition is raised: *FDW-specific condition — invalid handle*.
- 3) If *TRH* does not identify a <table reference> with a type of TABLE\_NAME, then an exception condition is raised: *FDW-specific condition — invalid handle*.
- 4) Let *NAME* be the value of the table name of the <table reference> identified by *TRH*.
- 5) Let *BL* be the value of BufferLength.
- 6) The General Rules of [Subclause 21.7, “Character string retrieval”](#), are applied to TableName, *NAME*, *BL*, and StringLength as *TARGET*, *VALUE*, *TARGET OCTET LENGTH*, and *RETURNED OCTET LENGTH*, respectively.

#### Conformance Rules

- 1) Without Feature M030, “SQL-server foreign data support”, a conforming foreign-data wrapper shall not contain an invocation of a <foreign-data wrapper interface routine> that contains a <foreign-data wrapper interface routine name> that contains GetTableRefTableName.

### 22.4.37 GetTableServerName

#### Function

Get the name of the foreign server associated with the foreign table identified by the given table reference handle.

#### Definition

```
GetTableServerName (
 TableReferenceHandle IN INTEGER,
 ServerName OUT CHARACTER(L),
 BufferLength IN SMALLINT,
 StringLength OUT SMALLINT)
RETURNS SMALLINT
```

where *L* has a maximum value equal to the implementation-defined length of an <identifier>.

#### General Rules

- 1) Let *TRH* be the value of TableReferenceHandle.
- 2) If *TRH* does not identify an allocated table reference description, then an exception condition is raised: *FDW-specific condition — invalid handle*.
- 3) Let *SN* be the server name associated with the foreign table identified by *TRH*.
- 4) Let *BL* be the value of BufferLength.
- 5) The General Rules of [Subclause 21.7](#), “Character string retrieval”, are applied to ServerName, *SN*, *BL*, and StringLength as *TARGET*, *VALUE*, *TARGET OCTET LENGTH*, and *RETURNED OCTET LENGTH*, respectively.

#### Conformance Rules

- 1) Without Feature M030, “SQL-server foreign data support”, a conforming foreign-data wrapper shall not contain an invocation of a <foreign-data wrapper interface routine> that contains a <foreign-data wrapper interface routine name> that contains GetTableServerName.

### 22.4.38 GetTRDHandle

#### Function

Get the descriptor handle of the table reference descriptor associated with a given table reference handle.

#### Definition

```
GetTRDHandle (
 TableReferenceHandle IN INTEGER,
 TRDHandle OUT INTEGER)
RETURNS SMALLINT
```

#### General Rules

- 1) Let *TRH* be the value of TableReferenceHandle.
- 2) If *TRH* does not identify an allocated table reference description, then an exception condition is raised: *FDW-specific condition — invalid handle*.
- 3) TRDHandle is set to the descriptor handle of the table reference descriptor associated with *TRH*.

#### Conformance Rules

- 1) Without Feature M030, “SQL-server foreign data support”, a conforming foreign-data wrapper shall not contain an invocation of a <foreign-data wrapper interface routine> that contains a <foreign-data wrapper interface routine name> that contains GetTRDHandle.

### 22.4.39 GetUserOpt

#### Function

Get the name and value of a generic option associated with the user mapping identified by the specified user handle, given an option number.

#### Definition

```

GetUserOpt (
 UserHandle IN INTEGER,
 OptionNumber IN INTEGER,
 OptionName OUT CHARACTER(L1),
 BufferLength1 IN SMALLINT,
 StringLength1 OUT SMALLINT,
 OptionValue OUT CHARACTER(L2),
 BufferLength2 IN SMALLINT,
 StringLength2 OUT SMALLINT)
RETURNS SMALLINT

```

where each of *L1* and *L2* has a maximum value equal to the implementation-defined length of a variable-length character string.

#### General Rules

- 1) Let *UH* be the value of UserHandle.
- 2) If *UH* does not identify an allocated user mapping description, then an exception condition is raised: *FDW-specific condition — invalid handle*.
- 3) Let *ON* be the value of OptionNumber.
- 4) Let *N* be the number of generic options associated with *UH*.
- 5) If *ON* is less than 1 (one), then an exception condition is raised: *FDW-specific condition — invalid option index*.
- 6) If *ON* is greater than *N*, then a completion condition is raised: *no data* and no further rules of this Subclause are applied.
- 7) Information from the *ON*-th generic option associated with *UH* is retrieved.
  - a) Let *NAME* be the name of the generic option.
  - b) The General Rules of Subclause 21.7, “Character string retrieval”, are applied to OptionName, *NAME*, BufferLength1, and StringLength1 as *TARGET*, *VALUE*, *TARGET OCTET LENGTH*, and *RETURNED OCTET LENGTH*, respectively.
  - c) Let *OPTIONVALUE* be the value of the generic option.

## 22.4 Foreign-data wrapper interface SQL-server routines

- d) The General Rules of Subclause 21.7, “Character string retrieval”, are applied to OptionValue, *OPTIONVALUE*, BufferLength2, and StringLength2 as *TARGET*, *VALUE*, *TARGET OCTET LENGTH*, and *RETURNED OCTET LENGTH*, respectively.

## Conformance Rules

- 1) Without Feature M030, “SQL-server foreign data support”, a conforming foreign-data wrapper shall not contain an invocation of a <foreign-data wrapper interface routine> that contains a <foreign-data wrapper interface routine name> that contains GetUserOpt.

### 22.4.40 GetUserOptByName

#### Function

Get the value of a generic option associated with the user mapping associated with the specified user handle, given the option name.

#### Definition

```
GetUserOptByName (
 UserHandle IN INTEGER,
 OptionName IN CHARACTER (L1) ,
 BufferLength1 IN SMALLINT,
 OptionValue OUT CHARACTER (L2) ,
 BufferLength2 IN SMALLINT,
 StringLength2 OUT SMALLINT)
RETURNS SMALLINT
```

where each of *L1* and *L2* has a maximum value equal to the implementation-defined length of a variable-length character string.

#### General Rules

- 1) Let *UH* be the value of UserHandle.
- 2) If *UH* does not identify an allocated user mapping description, then an exception condition is raised: *FDW-specific condition — invalid handle*.
- 3) Let *NL* be the value of BufferLength1.
- 4) Case:
  - a) If *NL* is not positive, then an exception condition is raised: *FDW-specific condition — invalid string length or buffer length*.
  - b) Otherwise, let *L* be *NL*, let *N* be the number of whole characters in the first *L* octets of OptionName, and let *NO* be the number of octets occupied by those *N* characters.
 

Case:

    - i) If *NO* ≠ *L*, then an exception condition is raised: *FDW-specific condition — invalid option name*.
    - ii) Otherwise, let *ON* be the first *L* octets of OptionName and let *TON* be the value of `TRIM ( BOTH ' ' FROM 'ON' )`
- 5) Case:
  - a) If *TON* is equivalent to the name of a generic option associated with *UH*, then:
    - i) Let *OPTIONVALUE* be the value of the generic option associated with *UH* whose name is equivalent to *TON*.

## 22.4 Foreign-data wrapper interface SQL-server routines

- ii) The General Rules of Subclause 21.7, “Character string retrieval”, are applied to OptionValue, *OPTIONVALUE*, BufferLength2, and StringLength2 as *TARGET*, *VALUE*, *TARGET OCTET LENGTH*, and *RETURNED OCTET LENGTH*, respectively.
- b) Otherwise, an exception condition is raised: *FDW-specific condition — option name not found*.

## Conformance Rules

- 1) Without Feature M030, “SQL-server foreign data support”, a conforming foreign-data wrapper shall not contain an invocation of a <foreign-data wrapper interface routine> that contains a <foreign-data wrapper interface routine name> that contains GetUserOptByName.

### 22.4.41 GetValExprColName

#### Function

Get the column name of a COLUMN\_NAME <value expression>, given its value expression handle.

#### Definition

```
GetValExprColName (
 ValueExpressionHandle IN INTEGER,
 ColumnName OUT CHARACTER(L),
 BufferLength IN SMALLINT,
 StringLength OUT SMALLINT)
RETURNS SMALLINT
```

where *L* has a maximum value equal to the implementation-defined length of a variable-length character string.

#### General Rules

- 1) Let *VEH* be the value of ValueExpressionHandle.
- 2) If *VEH* does not identify an allocated value expression description, then an exception condition is raised: *FDW-specific condition — invalid handle*.
- 3) If *VEH* does not identify a <value expression> with a type of COLUMN\_NAME, then an exception condition is raised: *FDW-specific condition — invalid handle*.
- 4) Let *NAME* be the value of the column name of the <value expression>.
- 5) Let *BL* be the value of BufferLength.
- 6) The General Rules of [Subclause 21.7, “Character string retrieval”](#), are applied to ColumnName, *NAME*, *BL*, and StringLength as *TARGET*, *VALUE*, *TARGET OCTET LENGTH*, and *RETURNED OCTET LENGTH*, respectively.

#### Conformance Rules

- 1) Without Feature M030, “SQL-server foreign data support”, a conforming foreign-data wrapper shall not contain an invocation of a <foreign-data wrapper interface routine> that contains a <foreign-data wrapper interface routine name> that contains GetValExprColName.



### 22.4.42 GetValueExpDesc

## Function

Get the handle for a value expression descriptor describing a <value expression>, given its value expression handle.

## Definition

```
GetValueExpDesc (
 ValueExpressionHandle IN INTEGER,
 ValueExpDescriptorHandle OUT INTEGER)
RETURNS SMALLINT
```

## General Rules

- 1) Let *VEH* be the value of ValueExpressionHandle.
- 2) If *VEH* does not identify an allocated <value expression> description, then an exception condition is raised: *FDW-specific condition — invalid handle*.
- 3) Let *VEDH* be the value expression descriptor handle associated with the value expression descriptor that describes the <value expression> identified by *VEH*.
- 4) ValueExpDescriptorHandle is set to *VEDH*.

## Conformance Rules

- 1) Without Feature M030, “SQL-server foreign data support”, a conforming foreign-data wrapper shall not contain an invocation of a <foreign-data wrapper interface routine> that contains a <foreign-data wrapper interface routine name> that contains GetValueExpDesc.

### 22.4.43 GetValueExpKind

#### Function

Get the kind of a <value expression>, given its value expression handle.

#### Definition

```
GetValueExpKind (
 ValueExpressionHandle IN INTEGER,
 ValueExpressionKind OUT SMALLINT)
RETURNS SMALLINT
```

#### General Rules

- 1) Let *VEH* be the value of ValueExpressionHandle.
- 2) If *VEH* does not identify an allocated <value expression> description, then an exception condition is raised: *FDW-specific condition — invalid handle*.
- 3) Let *VEK* be the kind of the <value expression> associated with *VEH*.  
NOTE 78 — The permissible values of the kind of a <value expression> are listed in Table 28, “Codes used for <value expression> kinds”.
- 4) ValueExpressionKind is set to *VEK*.

#### Conformance Rules

- 1) Without Feature M030, “SQL-server foreign data support”, a conforming foreign-data wrapper shall not contain an invocation of a <foreign-data wrapper interface routine> that contains a <foreign-data wrapper interface routine name> that contains GetValueExpKind.

### 22.4.44 GetValueExpName

#### Function

Get the name associated with a <value expression>.

#### Definition

```
GetValueExpName (
 ReplyHandle IN INTEGER,
 ValueExpressionHandle IN INTEGER,
 BufferLength IN INTEGER,
 ValueExpressionNameLength OUT INTEGER,
 ValueExpressionName OUT CHARACTER(L))
RETURNS SMALLINT
```

where *L* has a maximum value equal to the implementation-defined length of a variable-length character string.

#### General Rules

- 1) Let *VEH* be the value of ValueExpressionHandle.
- 2) If *VEH* does not identify an allocated <value expression> description, then an exception condition is raised: *FDW-specific condition — invalid handle*.
- 3) Let *VEN* be the name associated with *VEH*.
- 4) The General Rules of [Subclause 21.7](#), “Character string retrieval”, are applied to ValueExpressionName, *VEN*, BufferLength, and ValueExpressionNameLength as *TARGET*, *VALUE*, *TARGET OCTET LENGTH*, and *RETURNED OCTET LENGTH*, respectively.

#### Conformance Rules

- 1) Without Feature M030, “SQL-server foreign data support”, a conforming foreign-data wrapper shall not contain an invocation of a <foreign-data wrapper interface routine> that contains a <foreign-data wrapper interface routine name> that contains GetValueExpName.

### 22.4.45 GetValueExpTable

#### Function

Get the table reference handle with which the table associated with the <value expression> identified by the specified value expression handle is associated.

#### Definition

```
GetValueExpTable (
 ValueExpressionHandle IN INTEGER,
 TableReferenceHandle OUT INTEGER)
RETURNS SMALLINT
```

#### General Rules

- 1) Let *VEH* be the value of ValueExpressionHandle.
- 2) If *VEH* does not identify an allocated <value expression> description, then an exception condition is raised: *FDW-specific condition — invalid handle*.
- 3) Let *TBL* be the table associated with the allocated <value expression> identified by *VEH*. TableReferenceHandle is set to the table reference handle that identifies the table reference descriptor that describes *T*.

#### Conformance Rules

- 1) Without Feature M030, “SQL-server foreign data support”, a conforming foreign-data wrapper shall not contain an invocation of a <foreign-data wrapper interface routine> that contains a <foreign-data wrapper interface routine name> that contains GetValueExpTable.

### 22.4.46 GetVEChild

## Function

Get a handle for the <value expression>, identified by an ordinal position, simply contained in the <value expression> identified by the specified value expression handle.

## Definition

```
GetVEChild (
 ValueExpressionHandle IN INTEGER,
 Index IN SMALLINT,
 ChildValueExpressionHandle OUT INTEGER)
RETURNS SMALLINT
```

## General Rules

- 1) Let *VEH* be the value of ValueExpressionHandle.
- 2) If *VEH* does not identify an allocated <value expression> description, then an exception condition is raised: *FDW-specific condition — invalid handle*.
- 3) Let *NOC* be the number of <value expression>s immediately contained in the <value expression> to which *VEH* refers.
- 4) Let *I* be the value of Index.
- 5) If *I* is less than 1 (one), then an exception condition is raised: *FDW-specific condition — invalid option index*.
- 6) If *I* is greater than *NOC*, then a completion condition is raised: *no data*, and no further rules of this Subclause are applied.
- 7) ChildValueExpressionHandle is set to the value expression handle associated with the *I*-th simply contained <value expression>.

## Conformance Rules

- 1) Without Feature M030, “SQL-server foreign data support”, a conforming foreign-data wrapper shall not contain an invocation of a <foreign-data wrapper interface routine> that contains a <foreign-data wrapper interface routine name> that contains GetVEChild.

### 22.4.47 GetWrapperLibraryName

#### Function

Get the library name associated with the foreign-data wrapper identified by the specified wrapper handle.

#### Definition

```
GetWrapperLibraryName (
 WrapperHandle IN INTEGER ,
 WrapperLibraryName OUT CHARACTER(L) ,
 BufferLength IN SMALLINT ,
 StringLength OUT SMALLINT)
RETURNS SMALLINT
```

where *L* has a maximum value equal to the implementation-defined maximum length of a variable-length character string.

#### General Rules

- 1) Let *WH* be the value of WrapperHandle.
- 2) If *WH* does not identify an allocated foreign-data wrapper description, then an exception condition is raised: *FDW-specific condition — invalid handle*.
- 3) Let *WL* be the name of the library included in the foreign-data wrapper descriptor of the foreign-data wrapper associated with *WH*.
- 4) The General Rules of [Subclause 21.7](#), “Character string retrieval”, are applied to WrapperLibraryName, *WL*, BufferLength, and StringLength as *TARGET*, *VALUE*, *TARGET OCTET LENGTH*, and *RETURNED OCTET LENGTH*, respectively.

#### Conformance Rules

- 1) Without Feature M030, “SQL-server foreign data support”, a conforming foreign-data wrapper shall not contain an invocation of a <foreign-data wrapper interface routine> that contains a <foreign-data wrapper interface routine name> that contains GetWrapperLibraryName.

### 22.4.48 GetWrapperName

#### Function

Get the name of the foreign-data wrapper identified by a specified wrapper handle.

#### Definition

```
GetWrapperName (
 WrapperHandle IN INTEGER ,
 WrapperName OUT CHARACTER (L) ,
 BufferLength IN SMALLINT ,
 StringLength OUT SMALLINT)
RETURNS SMALLINT
```

where  $L$  has a maximum value equal to  $(2n+1)$ , where  $n$  is the implementation-defined length of an <identifier>.

NOTE 79 — The length  $(2n+1)$  supports the syntax of <foreign server name>, which is “<identifier><period><identifier>”.

#### General Rules

- 1) Let  $WH$  be the value of WrapperHandle.
- 2) If  $WH$  does not identify an allocated foreign-data wrapper description, then an exception condition is raised: *FDW-specific condition — invalid handle*.
- 3) Let  $WN$  be the foreign-data wrapper name included in the foreign-data wrapper descriptor of the foreign-data wrapper associated with  $WH$ .
- 4) The General Rules of Subclause 21.7, “Character string retrieval”, are applied to WrapperName,  $WN$ , BufferLength, and StringLength as *TARGET*, *VALUE*, *TARGET OCTET LENGTH*, and *RETURNED OCTET LENGTH*, respectively.

#### Conformance Rules

- 1) Without Feature M030, “SQL-server foreign data support”, a conforming foreign-data wrapper shall not contain an invocation of a <foreign-data wrapper interface routine> that contains a <foreign-data wrapper interface routine name> that contains GetWrapperName.

### 22.4.49 GetWrapperOpt

#### Function

Get the name and value of a generic option associated with the foreign-data wrapper identified by the specified wrapper handle, given an option number.

#### Definition

```
GetWrapperOpt (
 WrapperHandle IN INTEGER ,
 OptionNumber IN INTEGER ,
 OptionName OUT CHARACTER(L1) ,
 BufferLength1 IN SMALLINT ,
 StringLength1 OUT SMALLINT ,
 OptionValue OUT CHARACTER(L2) ,
 BufferLength2 IN SMALLINT ,
 StringLength2 OUT SMALLINT)
RETURNS SMALLINT
```

where each of *L1* and *L2* has a maximum value equal to the implementation-defined length of a variable-length character string.

#### General Rules

- 1) Let *WH* be the value of WrapperHandle.
- 2) If *WH* does not identify an allocated foreign-data wrapper description, then an exception condition is raised: *FDW-specific condition — invalid handle*.
- 3) Let *ON* be the value of OptionNumber.
- 4) Let *N* be the number of generic options associated with *WH*.
- 5) If *ON* is less than 1 (one), then an exception condition is raised: *FDW-specific condition — invalid option index*.
- 6) If *ON* is greater than *N*, then a completion condition is raised: *no data* and no further rules of this Subclause are applied.
- 7) Information from the *ON*-th generic option associated with *WH* is retrieved.
  - a) Let *NAME* be the name of the generic option.
  - b) The General Rules of Subclause 21.7, “Character string retrieval”, are applied to OptionName, *NAME*, BufferLength1, and StringLength1 as *TARGET*, *VALUE*, *TARGET OCTET LENGTH*, and *RETURNED OCTET LENGTH*, respectively.
  - c) Let *OPTIONVALUE* be the value of the generic option.



## 22.4 Foreign-data wrapper interface SQL-server routines

- d) The General Rules of Subclause 21.7, “Character string retrieval”, are applied to OptionValue, *OPTIONVALUE*, BufferLength2, and StringLength2 as *TARGET*, *VALUE*, *TARGET OCTET LENGTH*, and *RETURNED OCTET LENGTH*, respectively.

## Conformance Rules

- 1) Without Feature M030, “SQL-server foreign data support”, a conforming foreign-data wrapper shall not contain an invocation of a <foreign-data wrapper interface routine> that contains a <foreign-data wrapper interface routine name> that contains GetWrapperOpt.

### 22.4.50 GetWrapperOptByName

#### Function

Get the value of a generic option associated with the foreign-data wrapper identified by the specified wrapper handle, given the option name.

#### Definition

```
GetWrapperOptByName (
 WrapperHandle IN INTEGER ,
 OptionName IN CHARACTER(L1) ,
 BufferLength1 IN SMALLINT ,
 OptionValue OUT CHARACTER(L2) ,
 BufferLength2 IN SMALLINT ,
 StringLength2 OUT SMALLINT)
RETURNS SMALLINT
```

where each of *L1* and *L2* has a maximum value equal to the implementation-defined length of a variable-length character string.

#### General Rules

- 1) Let *WH* be the value of WrapperHandle.
- 2) If *WH* does not identify an allocated foreign-data wrapper description, then an exception condition is raised: *FDW-specific condition — invalid handle*.
- 3) Let *NL* be the value of BufferLength1.
- 4) Case:
  - a) If *NL* is not positive, then an exception condition is raised: *FDW-specific condition — invalid string length or buffer length*.
  - b) Otherwise, let *L* be *NL*, let *N* be the number of whole characters in the first *L* octets of OptionName, and let *NO* be the number of octets occupied by those *N* characters.
 

Case:

    - i) If *NO* ≠ *L*, then an exception condition is raised: *FDW-specific condition — invalid option name*.
    - ii) Otherwise, let *ON* be the first *L* octets of OptionName and let *TON* be the value of `TRIM ( BOTH ' ' FROM 'ON' )`
- 5) Case:
  - a) If *TON* is equivalent to the name of a generic option associated with *WH*, then:
    - i) Let *OPTIONVALUE* be the value of the generic option associated with *WH* whose name is equivalent to *TON*.

## 22.4 Foreign-data wrapper interface SQL-server routines

- ii) The General Rules of Subclause 21.7, “Character string retrieval”, are applied to OptionValue, *OPTIONVALUE*, BufferLength2, and StringLength2 as *TARGET*, *VALUE*, *TARGET OCTET LENGTH*, and *RETURNED OCTET LENGTH*, respectively.
- b) Otherwise, an exception condition is raised: *FDW-specific condition — option name not found*.

## Conformance Rules

- 1) Without Feature M030, “SQL-server foreign data support”, a conforming foreign-data wrapper shall not contain an invocation of a <foreign-data wrapper interface routine> that contains a <foreign-data wrapper interface routine name> that contains GetWrapperOptByName.

### 22.4.51 SetDescriptor

#### Function

Set a field in the foreign-data wrapper descriptor area identified by the specified descriptor handle.

#### Definition

```
SetDescriptor (
 DescriptorHandle IN INTEGER,
 RecordNumber IN SMALLINT,
 FieldIdentifier IN SMALLINT,
 Value IN ANY,
 BufferLength IN INTEGER)
RETURNS SMALLINT
```

#### General Rules

- 1) Let *D* be the allocated foreign-data wrapper descriptor area identified by DescriptorHandle and let *N* be the value of the COUNT field of *D*.
- 2) Let *HL1* be the standard host language in which the SQL-server is written and let *HL2* be the standard host language in which the foreign-data wrapper is written.
- 3) Let *FI* be the value of FieldIdentifier.
- 4) If *FI* is not one of the code values in Table 30, “Codes used for foreign-data wrapper descriptor fields”, then an exception condition is raised: *FDW-specific condition — invalid descriptor field identifier*.
- 5) Let *RN* be the value of RecordNumber.
- 6) Let *TYPE* be the value of the Type column in the row of Table 30, “Codes used for foreign-data wrapper descriptor fields”, that contains *FI*.
- 7) If *TYPE* is 'ITEM' and *RN* is less than 1 (one), then an exception condition is raised: *dynamic SQL error — invalid descriptor index*.
- 8) Let *IDA* be the item descriptor area of *D* specified by *RN*.
- 9) If an exception condition is raised in any of the following General Rules, then all fields of *IDA* for which specific values were provided in the invocation of SetDescField ( ) are set to implementation-dependent values and the value of COUNT for *D* is unchanged.
- 10) Information is set in *D*.

NOTE 80 — Let *MBS* be the value of the May Be Set column in the row of Table 33, “Ability to set foreign-data wrapper descriptor fields”, that contains *FI* in the column that contains the descriptor type *DT*. If *MBS* is 'No', then the effect on the field is implementation-dependent.

Case:

- a) If *FI* indicates COUNT, then

## 22.4 Foreign-data wrapper interface SQL-server routines

Case:

- i) If the memory requirements to manage the foreign-data wrapper descriptor area cannot be satisfied, then an exception condition is raised: *FDW-specific condition — memory allocation error*.
  - ii) Otherwise, the count of the number of foreign-data wrapper item descriptor areas is set to the value of Value.
- b) If *FI* indicates OCTET\_LENGTH, then the value of the OCTET\_LENGTH field of *IDA* is set to the value of Value.
- c) If *FI* indicates DATA\_POINTER, then the value of the DATA\_POINTER field of *IDA* is set to the address of Value. If Value is a null pointer, then the address is set to 0 (zero).
- d) If *FI* indicates DATA, then the value of the DATA field of *IDA* is set to the value of Value.
- e) If *FI* indicates INDICATOR, then the value of the INDICATOR field of *IDA* is set to the value of Value.
- f) If *FI* indicates RETURNED\_CARDINALITY, then the value of the RETURNED\_CARDINALITY field of *IDA* is set to the value of Value.
- g) If *FI* indicates CHARACTER\_SET\_CATALOG, CHARACTER\_SET\_SCHEMA, or CHARACTER\_SET\_NAME, then:
  - i) Let *BL* be the value of BufferLength.
  - ii) Case:
    - 1) If *BL* is not positive, then an exception condition is raised: *FDW-specific condition — invalid string length or buffer length*.
    - 2) Otherwise, let *L* be *BL*, let *FV* be the first *L* octets of Value, and let *TFV* be the value of `TRIM ( BOTH ' ' FROM 'FV' )`
  - iii) Let *ML* be the maximum length in characters allowed for an <identifier> as specified in the Syntax Rules of Subclause 5.4, “Names and identifiers”, in ISO/IEC 9075-2, and let *TFVL* be the length in characters of *TFV*.
  - iv) Case:
    - 1) If *TFVL* is greater than *ML*, then *FV* is set to the first *ML* characters of *TFV* and a completion condition is raised: *warning — string data, right truncation*.
    - 2) Otherwise, *FV* is set to *TFV*.
  - v) Case:
    - 1) If *FI* indicates CHARACTER\_SET\_CATALOG and *FV* does not conform to the Format and Syntax Rules of an <identifier>, then an exception condition is raised: *invalid catalog name*.
    - 2) If *FI* indicates CHARACTER\_SET\_SCHEMA and *FV* does not conform to the Format and Syntax Rules of an <identifier>, then an exception condition is raised: *invalid schema name*.
    - 3) If *FI* indicates CHARACTER\_SET\_NAME and *FV* does not conform to the Format and Syntax Rules of an <identifier>, then an exception condition is raised: *invalid character set name*.

- vi) The value of the field of *IDA* identified by *FI* is set to the value of *FV*.
  - h) Otherwise, the value of the field of *IDA* identified by *FI* is set to the value of *Value*.
- 11) If *FI* indicates LEVEL, then:
- a) If *RI* is 1 (one) and *Value* is not 0 (zero), then an exception condition is raised: *dynamic SQL error — invalid LEVEL value*.
  - b) If *RI* is greater than 1 (one), then let *PIDA* be *IDA*'s immediately preceding foreign-data wrapper item descriptor area and let *K* be its LEVEL value.
    - i) If *Value* is *K*+1 and *TYPE* in *PIDA* does not indicate ROW, ARRAY, ARRAY LOCATOR, MULTISSET, or MULTISSET LOCATOR, then an exception condition is raised: *dynamic SQL error — invalid LEVEL value*.
    - ii) If *Value* is greater than *K*+1, then an exception condition is raised: *dynamic SQL error — invalid LEVEL value*.
    - iii) If *Value* is less than *K*+1, then let *OIDA<sub>i</sub>* be the *i*-th foreign-data wrapper item descriptor area to which *PIDA* is subordinate and whose *TYPE* field indicates ROW. Let *NS<sub>i</sub>* be the number of immediately subordinate descriptor areas of *OIDA<sub>i</sub>* between *OIDA<sub>i</sub>* and *IDA*, and let *D<sub>i</sub>* be the value of DEGREE of *OIDA<sub>i</sub>*.
      - 1) For each *OIDA<sub>i</sub>* whose LEVEL value is greater than *V*, if *D<sub>i</sub>* is not equal to *NS<sub>i</sub>*, then an exception condition is raised: *dynamic SQL error — invalid LEVEL value*.
      - 2) If *K* is not 0 (zero), then let *OIDA<sub>i</sub>* be the *OIDA<sub>j</sub>* whose LEVEL value is *K*. If there exists no such *OIDA<sub>j</sub>* or *D<sub>j</sub>* is not greater than *NS<sub>j</sub>*, then an exception condition is raised: *dynamic SQL error — invalid LEVEL value*.
  - c) The value of LEVEL in *IDA* is set to *Value*.
- 12) If *TYPE* is 'ITEM' and *RN* is greater than *N*, then the COUNT field of *D* is set to *RN*.
- 13) Case:
- a) If *HL1* and *HL2* are both pointer-supporting languages, and if *FI* indicates TYPE, LENGTH, OCTET\_LENGTH, PRECISION, SCALE, DATETIME\_INTERVAL\_CODE, DATETIME\_INTERVAL\_PRECISION, PARAMETER\_MODE, PARAMETER\_ORDINAL\_POSITION, PARAMETER\_SPECIFIC\_CATALOG, PARAMETER\_SPECIFIC\_SCHEMA, PARAMETER\_SPECIFIC\_NAME, CHARACTER\_SET\_CATALOG, CHARACTER\_SET\_SCHEMA, CHARACTER\_SET\_NAME, USER\_DEFINED\_TYPE\_CATALOG, USER\_DEFINED\_TYPE\_SCHEMA, USER\_DEFINED\_TYPE\_NAME, SCOPE\_CATALOG, SCOPE\_SCHEMA, or SCOPE\_NAME, then the DATA\_POINTER field of *IDA* is set to 0 (zero).
  - b) Otherwise, if *FI* indicates TYPE, LENGTH, OCTET\_LENGTH, PRECISION, SCALE, DATETIME\_INTERVAL\_CODE, DATETIME\_INTERVAL\_PRECISION, PARAMETER\_MODE, PARAMETER\_ORDINAL\_POSITION, PARAMETER\_SPECIFIC\_CATALOG, PARAMETER\_SPECIFIC\_SCHEMA, PARAMETER\_SPECIFIC\_NAME, CHARACTER\_SET\_CATALOG, CHARACTER\_SET\_SCHEMA, CHARACTER\_SET\_NAME, USER\_DEFINED\_TYPE\_CATALOG, USER\_DEFINED\_TYPE\_SCHEMA, USER\_DEFINED\_TYPE\_NAME, SCOPE\_CATALOG, SCOPE\_SCHEMA, or SCOPE\_NAME, then the value of the DATA field of *IDA* is set to 0 (zero).

22.4 Foreign-data wrapper interface SQL-server routines

- 14) If *FI* indicates DATA or if *FI* indicates DATA\_POINTER, and Value is not a null pointer, and *IDA* is not consistent as specified in Subclause 21.1, “Description of foreign-data wrapper item descriptor areas”, then an exception condition is raised: *FDW-specific condition — inconsistent descriptor information*.
- 15) Let *V* be the value of Value.
- 16) If *FI* indicates TYPE, then:
- a) All the other fields of *IDA* are set to implementation-dependent values.
  - b) Case:
    - i) If *V* indicates CHARACTER, CHARACTER VARYING or CHARACTER LARGE OBJECT then the CHARACTER\_SET\_CATALOG, CHARACTER\_SET\_SCHEMA, and CHARACTER\_SET\_NAME fields of *IDA* are set to the values for the default character set name for the SQL-session and the LENGTH field of *IDA* is set to the maximum possible length in characters of the indicated data type.
    - ii) If *V* indicates BINARY LARGE OBJECT, then the LENGTH field of *IDA* is set to the maximum possible length in octets of the indicated data type.
    - iii) If *V* indicates a <datetime type>, then the PRECISION field of *IDA* is set to 0 (zero).
    - iv) If *V* indicates INTERVAL, then the DATETIME\_INTERVAL\_PRECISION field of *IDA* is set to 2.
    - v) If *V* indicates NUMERIC or DECIMAL, then the SCALE field of *IDA* is set to 0 (zero) and the PRECISION field of *IDA* is set to the implementation-defined default value for the precision of the NUMERIC or DECIMAL data types, respectively.
    - vi) If *V* indicates SMALLINT, INTEGER, or BIGINT, then the SCALE field of *IDA* is set to 0 (zero) and the PRECISION field of *IDA* is set to the implementation-defined value for the precision of the SMALLINT, INTEGER, or BIGINT data types, respectively.
    - vii) If *V* indicates FLOAT, then the PRECISION field of *IDA* is set to the implementation-defined default value for the precision of the FLOAT data type.
    - viii) If *V* indicates REAL or DOUBLE PRECISION, then the PRECISION field of *IDA* is set to the implementation-defined value for the precision of the REAL or DOUBLE PRECISION data types, respectively.
    - ix) If *V* indicates an implementation-defined data type, then an implementation-defined set of fields of *IDA* are set to implementation-defined default values.
    - x) Otherwise, an exception condition is raised: *FDW-specific condition — invalid data type*.
- 17) If *FI* indicates DATETIME\_INTERVAL\_CODE and the TYPE field of *IDA* indicates a <datetime type>, then:
- a) All the fields of *IDA* other than DATETIME\_INTERVAL\_CODE and TYPE are set to implementation-dependent values.
  - b) Case:
    - i) If *V* indicates DATE, TIME, or TIME WITH TIME ZONE, then the PRECISION field of *IDA* is set to 0 (zero).

- ii) If *V* indicates `TIMESTAMP` or `TIMESTAMP WITH TIME ZONE`, then the `PRECISION` field of *IDA* is set to 6.
- 18) If *FI* indicates `DATETIME_INTERVAL_CODE` and the `TYPE` field of *IDA* indicates `INTERVAL`, then the `DATETIME_INTERVAL_PRECISION` field of *IDA* is set to 2 and
- Case:
- a) If *V* indicates `DAY TO SECOND`, `HOUR TO SECOND`, `MINUTE TO SECOND`, or `SECOND`, then the `PRECISION` field of *IDA* is set to 6.
  - b) Otherwise, the `PRECISION` field of *IDA* is set to 0 (zero).

## Conformance Rules

- 1) Without Feature M030, “SQL-server foreign data support”, a conforming foreign-data wrapper shall not contain an invocation of a <foreign-data wrapper interface routine> that contains a <foreign-data wrapper interface routine name> that contains `SetDescriptor`.



## 22.5 Foreign-data wrapper interface general routines

### 22.5.1 GetDiagnostics

#### Function

Get information from a foreign-data wrapper diagnostics area.

#### Definition

```
GetDiagnostics (
 HandleType IN SMALLINT ,
 Handle IN INTEGER ,
 RecordNumber IN SMALLINT ,
 DiagIdentifier IN SMALLINT ,
 DiagInfo OUT ANY ,
 BufferLength IN SMALLINT ,
 StringLength OUT SMALLINT)
RETURNS SMALLINT
```

#### General Rules

- 1) Let *HT* be the value of HandleType.
- 2) If *HT* is not one of the code values in Table 31, “Codes used for foreign-data wrapper handle types”, then an exception condition is raised: *FDW-specific condition — invalid handle*.
- 3) Case:
  - a) If *HT* indicates EXECUTION HANDLE and Handle does not identify an allocated execution description, then an exception condition is raised: *FDW-specific condition — invalid handle*.
  - b) If *HT* indicates FSCONNECTION HANDLE and Handle does not identify an allocated FS-connection, then an exception condition is raised: *FDW-specific condition — invalid handle*.
  - c) If *HT* indicates REPLY HANDLE and Handle does not identify an allocated reply description, then an exception condition is raised: *FDW-specific condition — invalid handle*.
  - d) If *HT* indicates REQUEST HANDLE and Handle does not identify an allocated request description, then an exception condition is raised: *FDW-specific condition — invalid handle*.
  - e) If *HT* indicates SERVER HANDLE and Handle does not identify an allocated foreign-server description, then an exception condition is raised: *FDW-specific condition — invalid handle*.
  - f) If *HT* indicates TABLEREFERENCE HANDLE and Handle does not identify an allocated table reference description, then an exception condition is raised: *FDW-specific condition — invalid handle*.
  - g) If *HT* indicates USER HANDLE and Handle does not identify an allocated user mapping description, then an exception condition is raised: *FDW-specific condition — invalid handle*.

## 22.5 Foreign-data wrapper interface general routines

- h) If *HT* indicates VALUEEXPRESSION HANDLE and Handle does not identify an allocated value expression description, then an exception condition is raised: *FDW-specific condition — invalid handle*.
  - i) If *HT* indicates WRAPPER HANDLE and Handle does not identify an allocated foreign-data wrapper description, then an exception condition is raised: *FDW-specific condition — invalid handle*.
  - j) If *HT* indicates WRAPPERENV HANDLE and Handle does not identify an allocated FDW-environment, then an exception condition is raised: *FDW-specific condition — invalid handle*.
- 4) Let *DI* be the value of DiagIdentifier.
  - 5) If *DI* is not one of the code values in Table 29, “Codes used for foreign-data wrapper diagnostic fields”, then an exception condition is raised: *FDW-specific condition — invalid attribute value*.
  - 6) Let *TYPE* be the value of the Type column in the row that contains *DI* in Table 29, “Codes used for foreign-data wrapper diagnostic fields”
  - 7) Let *RN* be the value of RecordNumber.
  - 8) Let *R* be the most recently executed foreign-data wrapper interface routine, other than GetDiagnostics(), for which Handle was passed as the value of an input handle and let *N* be the number of status records generated by the execution of *R*.  
NOTE 81 — The GetDiagnostics() routine may cause exception or completion conditions to be raised, but it does not cause diagnostic information to be generated.
  - 9) If *TYPE* is 'STATUS', then:
    - a) If *RN* is less than 1 (one), then an exception condition is raised: *invalid condition number*.
    - b) If *RN* is greater than *N*, then a completion condition is raised: *no data*, and no further rules of this Subclause are applied.
  - 10) If *TYPE* is 'HEADER', then header information from the diagnostics area associated with the resource identified by Handle is retrieved.
    - a) If *DI* indicates NUMBER, then the value retrieved is *N*.
    - b) If *DI* indicates RETURNCODE, then the value retrieved is the code indicating the basic result of the execution of *R*. Subclause 4.17.4, “Return codes”, specifies the code values and their meanings.  
NOTE 82 — The value retrieved will never indicate **Invalid handle** or **Data needed**, since no diagnostic information is generated if this is the basic result of the execution of *R*.
    - c) If *DI* indicates MORE, then the value retrieved is  
Case:
      - i) If more conditions were raised during execution of *R* than have been stored in the diagnostics area, then 1 (one).
      - ii) If all the conditions that were raised during execution of *R* have been stored in the diagnostics area, then 0 (zero).
    - d) If *DI* indicates an implementation-defined diagnostics header field, then the value retrieved is the value of the implementation-defined diagnostics header field.
  - 11) If *TYPE* is 'STATUS', then information from the *RN*-th status record in the foreign-data wrapper diagnostics area associated with the resource identified by Handle is retrieved.

22.5 Foreign-data wrapper interface general routines

- a) If *DI* indicates `SQLSTATE`, then the value retrieved is the `SQLSTATE` value corresponding to the status condition.
- b) If *DI* indicates `NATIVE_CODE`, then the value retrieved is the implementation-defined native error code corresponding to the status condition.
- c) If *DI* indicates `MESSAGE_TEXT`, then the value retrieved is an implementation-defined character string.  
NOTE 83 — An implementation may provide <space>s or a zero-length string or a character string that describes the status condition.
- d) If *DI* indicates `MESSAGE_LENGTH`, then the value retrieved is the length in characters of the character string value of `MESSAGE_TEXT` corresponding to the status condition.
- e) If *DI* indicates `MESSAGE_OCTET_LENGTH`, then the value retrieved is the length in octets of the character string value of `MESSAGE_TEXT` corresponding to the status condition.
- f) If *DI* indicates `CLASS_ORIGIN`, then the value retrieved is the identification of the naming authority that defined the class value of the `SQLSTATE` value corresponding to the status condition. That value shall be 'ISO 9075' if the class value is fully defined in [Subclause 26.1](#), “`SQLSTATE`”, and shall be an implementation-defined character string other than 'ISO 9075' for any implementation-defined class value.
- g) If *DI* indicates `SUBCLASS_ORIGIN`, then the value retrieved is the identification of the naming authority that defined the subclass value of the `SQLSTATE` value corresponding to the status condition. That value shall be 'ISO 9075' if the class value is fully defined in [Subclause 26.1](#), “`SQLSTATE`”, and shall be an implementation-defined character string other than 'ISO 9075' for any implementation-defined subclass value.
- h) If *DI* indicates an implementation-defined diagnostics status field, then the value retrieved is the value of the implementation-defined diagnostics status field.

12) Let *V* be the value retrieved.

13) If *DI* indicates a diagnostics field whose row in [Table 3](#), “[Fields used in foreign-data wrapper diagnostics areas](#)”, contains a Data Type that is neither `CHARACTER` nor `CHARACTER VARYING`, then `DiagInfo` is set to *V* and no further rules of this Subclause are applied.

14) Let *BL* be the value of `BufferLength`.

15) If *BL* is not greater than zero, then an exception condition is raised: *FDW-specific condition — invalid string length or buffer length*.

16) Let *L* be the length in octets of *V*.

17) If `StringLength` is not a null pointer, then `StringLength` is set to *L*.

18) Case:

- a) If *L* is not greater than *BL*, then the first *L* octets of `DiagInfo` are set to *V* and the values of the remaining octets of `DiagInfo` are implementation-dependent.
- b) Otherwise, `DiagInfo` is set to the first *BL* octets of *V*.

## Conformance Rules

- 1) Without Feature M031, “Foreign-data wrapper general routines”, a conforming foreign-data wrapper shall not contain an invocation of a <foreign-data wrapper interface routine> that contains a <foreign-data wrapper interface routine name> that contains AllocQueryContext.
- 2) Without Feature M031, “Foreign-data wrapper general routines”, a conforming SQL-server shall not contain an invocation of a <foreign-data wrapper interface routine> that contains a <foreign-data wrapper interface routine name> that contains GetDiagnostics.

*(Blank page)*

## 23 Diagnostics management

*This Clause modifies Clause 22, “Diagnostics management”, in ISO/IEC 9075-2.*

### 23.1 <get diagnostics statement>

*This Subclause modifies Subclause 22.1, “<get diagnostics statement>”, in ISO/IEC 9075-2.*

#### Function

Get exception or completion condition information from the diagnostics area.

#### Format

*No additional Format items.*

#### Syntax Rules

*No additional Syntax Rules.*

#### Access Rules

*No additional Access Rules.*

#### General Rules

1) *Table 36, “SQL-statement codes”, modifies Table 31, “SQL-statement codes”, in ISO/IEC 9075-2.*

**Table 36 — SQL-statement codes**

| SQL-statement                               | Identifier                 | Code |
|---------------------------------------------|----------------------------|------|
| <i>All alternatives from ISO/IEC 9075-2</i> |                            |      |
| <alter foreign-data wrapper statement>      | ALTER FOREIGN DATA WRAPPER | 120  |
| <alter routine mapping statement>           | ALTER ROUTINE MAPPING      | 130  |
| <alter foreign server statement>            | ALTER SERVER               | 108  |

**CD ISO/IEC 9075-9:2007 (E)**  
**23.1 <get diagnostics statement>**

| <b>SQL-statement</b>                                                                                                     | <b>Identifier</b>                                                                                                           | <b>Code</b>           |
|--------------------------------------------------------------------------------------------------------------------------|-----------------------------------------------------------------------------------------------------------------------------|-----------------------|
| <alter foreign table statement>                                                                                          | ALTER FOREIGN TABLE                                                                                                         | 104                   |
| <alter user mapping statement>                                                                                           | ALTER USER MAPPING                                                                                                          | 123                   |
| <drop foreign-data wrapper statement>                                                                                    | DROP FOREIGN DATA WRAPPER                                                                                                   | 121                   |
| <drop foreign server statement>                                                                                          | DROP SERVER                                                                                                                 | 110                   |
| <drop foreign table statement>                                                                                           | DROP FOREIGN TABLE                                                                                                          | 105                   |
| <drop routine mapping statement>                                                                                         | DROP ROUTINE MAPPING                                                                                                        | 131                   |
| <drop user mapping statement>                                                                                            | DROP USER MAPPING                                                                                                           | 124                   |
| <foreign-data wrapper definition>                                                                                        | CREATE FOREIGN DATA WRAPPER                                                                                                 | 119                   |
| <foreign server definition>                                                                                              | CREATE SERVER                                                                                                               | 107                   |
| <foreign table definition>                                                                                               | CREATE FOREIGN TABLE                                                                                                        | 103                   |
| <import foreign schema statement>                                                                                        | IMPORT FOREIGN SCHEMA                                                                                                       | 125                   |
| <routine mapping definition>                                                                                             | CREATE ROUTINE MAPPING                                                                                                      | 132                   |
| <set passthrough statement>                                                                                              | SET PASSTHROUGH                                                                                                             | 126                   |
| <user mapping definition>                                                                                                | CREATE USER MAPPING                                                                                                         | 122                   |
| Statements that are defined by a foreign-data wrapper                                                                    | A character string value defined by a foreign-data wrapper different from the value associated with any other SQL-statement | <i>x</i> <sup>1</sup> |
| <sup>1</sup> An implementation-defined negative number different from the value associated with any other SQL-statement. |                                                                                                                             |                       |

## **Conformance Rules**

*No additional Conformance Rules.*

## 24 Information Schema

*This Clause modifies Clause 5, “Information Schema”, in ISO/IEC 9075-11.*

### 24.1 ATTRIBUTES view

*This Subclause modifies Subclause 5.11, “ATTRIBUTES view”, in ISO/IEC 9075-11.*

#### Function

Identify the attributes of user-defined types defined in this catalog that are accessible to a given user.

#### Definition

Add the following columns to the end of outermost select list of the view definition:

```
, D1.DATALINK_LINK_CONTROL, D1.DATALINK_INTEGRITY, D1.DATALINK_READ_PERMISSION,
D1.DATALINK_WRITE_PERMISSION, D1.DATALINK_RECOVERY, D1.DATALINK_UNLINK
```

#### Conformance Rules

- 1) **Insert this CR** Without Feature M001, “Datalinks”, conforming SQL language shall not reference INFORMATION\_SCHEMA . ATTRIBUTES . DATALINK\_INTEGRITY.
- 2) **Insert this CR** Without Feature M001, “Datalinks”, conforming SQL language shall not reference INFORMATION\_SCHEMA . ATTRIBUTES . DATALINK\_LINK\_CONTROL.
- 3) **Insert this CR** Without Feature M001, “Datalinks”, conforming SQL language shall not reference INFORMATION\_SCHEMA . ATTRIBUTES . DATALINK\_READ\_PERMISSION.
- 4) **Insert this CR** Without Feature M001, “Datalinks”, conforming SQL language shall not reference INFORMATION\_SCHEMA . ATTRIBUTES . DATALINK\_RECOVERY.
- 5) **Insert this CR** Without Feature M001, “Datalinks”, conforming SQL language shall not reference INFORMATION\_SCHEMA . ATTRIBUTES . DATALINK\_UNLINK.
- 6) **Insert this CR** Without Feature M001, “Datalinks”, conforming SQL language shall not reference INFORMATION\_SCHEMA . ATTRIBUTES . DATALINK\_WRITE\_PERMISSION.



## 24.2 COLUMN\_OPTIONS view

### Function

Identify the generic options specified for columns that are defined in this catalog.

### Definition

```
CREATE VIEW COLUMN_OPTIONS AS
 SELECT TABLE_CATALOG, TABLE_SCHEMA, TABLE_NAME,
 COLUMN_NAME, OPTION_NAME, OPTION_VALUE
 FROM DEFINITION_SCHEMA.COLUMN_OPTIONS CO
 WHERE (CO.TABLE_CATALOG, CO.TABLE_SCHEMA, CO.TABLE_NAME, CO.COLUMN_NAME)
 IN (SELECT CP.TABLE_CATALOG, CP.TABLE_SCHEMA, CP.TABLE_NAME,
 CP.COLUMN_NAME
 FROM DEFINITION_SCHEMA.COLUMN_PRIVILEGES AS CP
 WHERE (CP.GRANTEE IN
 ('PUBLIC', CURRENT_USER)
 OR
 CP.GRANTEE IN
 (SELECT ROLE_NAME
 FROM ENABLED_ROLES)))
 AND
 CO.TABLE_CATALOG
 = (SELECT CATALOG_NAME
 FROM INFORMATION_SCHEMA_CATALOG_NAME) ;

GRANT SELECT ON TABLE COLUMN_OPTIONS
 TO PUBLIC WITH GRANT OPTION;
```

### Conformance Rules

- 1) Without Feature M004, “Foreign data support”, conforming SQL language shall not reference INFORMATION\_SCHEMA . COLUMN\_OPTIONS.

## 24.3 COLUMNS view

*This Subclause modifies Subclause 5.21, “COLUMNS view”, in ISO/IEC 9075-11.*

### Function

Identify the columns of tables defined in this catalog that are accessible to a given user.

### Definition

Add the following columns to the end of outermost select list of the view definition:

, DATALINK\_LINK\_CONTROL, DATALINK\_INTEGRITY, DATALINK\_READ\_PERMISSION,  
DATALINK\_WRITE\_PERMISSION, DATALINK\_RECOVERY, DATALINK\_UNLINK

### Conformance Rules

- 1) **Insert this CR** Without Feature M001, “Datalinks”, conforming SQL language shall not reference INFORMATION\_SCHEMA . COLUMNS . DATALINK\_INTEGRITY.
- 2) **Insert this CR** Without Feature M001, “Datalinks”, conforming SQL language shall not reference INFORMATION\_SCHEMA . COLUMNS . DATALINK\_LINK\_CONTROL.
- 3) **Insert this CR** Without Feature M001, “Datalinks”, conforming SQL language shall not reference INFORMATION\_SCHEMA . COLUMNS . DATALINK\_READ\_PERMISSION.
- 4) **Insert this CR** Without Feature M001, “Datalinks”, conforming SQL language shall not reference INFORMATION\_SCHEMA . COLUMNS . DATALINK\_RECOVERY.
- 5) **Insert this CR** Without Feature M001, “Datalinks”, conforming SQL language shall not reference INFORMATION\_SCHEMA . COLUMNS . DATALINK\_UNLINK.
- 6) **Insert this CR** Without Feature M001, “Datalinks”, conforming SQL language shall not reference INFORMATION\_SCHEMA . COLUMNS . DATALINK\_WRITE\_PERMISSION.

## 24.4 FOREIGN\_DATA\_WRAPPER\_OPTIONS view

### Function

Identify the options specified for foreign-data wrappers that are defined in this catalog.

### Definition

```
CREATE VIEW FOREIGN_DATA_WRAPPER_OPTIONS AS
 SELECT FOREIGN_DATA_WRAPPER_CATALOG, FOREIGN_DATA_WRAPPER_NAME,
 OPTION_NAME, OPTION_VALUE
 FROM DEFINITION_SCHEMA.FOREIGN_DATA_WRAPPER_OPTIONS WO
 WHERE (WO.FOREIGN_DATA_WRAPPER_CATALOG, '', WO.FOREIGN_DATA_WRAPPER_NAME)
 IN (SELECT UP.OBJECT_CATALOG, UP.OBJECT_SCHEMA, UP.OBJECT_NAME
 FROM DEFINITION_SCHEMA.USAGE_PRIVILEGES AS UP
 WHERE (UP.GRANTEE IN
 ('PUBLIC', CURRENT_USER)
 OR
 UP.GRANTEE IN
 (SELECT ROLE_NAME
 FROM ENABLED_ROLES))))
 AND
 WO.FOREIGN_DATA_WRAPPER_CATALOG
 = (SELECT CATALOG_NAME
 FROM INFORMATION_SCHEMA.CATALOG_NAME) ;

GRANT SELECT ON TABLE FOREIGN_DATA_WRAPPER_OPTIONS
 TO PUBLIC WITH GRANT OPTION;
```

### Conformance Rules

- 1) Without Feature F391, “Long identifiers”, conforming SQL language shall not reference INFORMATION\_SCHEMA . FOREIGN\_DATA\_WRAPPER\_OPTIONS.
- 2) Without Feature M004, “Foreign data support”, conforming SQL language shall not reference INFORMATION\_SCHEMA . FOREIGN\_DATA\_WRAPPER\_OPTIONS.

## 24.5 FOREIGN\_DATA\_WRAPPERS view

### Function

Identify the foreign-data wrappers that are defined in this catalog.

### Definition

```
CREATE VIEW FOREIGN_DATA_WRAPPERS AS
 SELECT FOREIGN_DATA_WRAPPER_CATALOG, FOREIGN_DATA_WRAPPER_NAME,
 AUTHORIZATION_IDENTIFIER, LIBRARY_NAME, FOREIGN_DATA_WRAPPER_LANGUAGE
 FROM DEFINITION_SCHEMA.FOREIGN_DATA_WRAPPERS W
 WHERE (W.FOREIGN_DATA_WRAPPER_CATALOG, '', W.FOREIGN_DATA_WRAPPER_NAME)
 IN (SELECT UP.OBJECT_CATALOG, UP.OBJECT_SCHEMA, UP.OBJECT_NAME
 FROM DEFINITION_SCHEMA.USAGE_PRIVILEGES AS UP
 WHERE (UP.GRANTEE IN
 ('PUBLIC', CURRENT_USER)
 OR
 UP.GRANTEE IN
 (SELECT ROLE_NAME
 FROM ENABLED_ROLES)))
 AND
 W.FOREIGN_DATA_WRAPPER_CATALOG
 = (SELECT CATALOG_NAME
 FROM INFORMATION_SCHEMA.CATALOG_NAME) ;

GRANT SELECT ON TABLE FOREIGN_DATA_WRAPPERS
 TO PUBLIC WITH GRANT OPTION;
```

### Conformance Rules

- 1) Without Feature F391, “Long identifiers”, conforming SQL language shall not reference INFORMATION\_SCHEMA . FOREIGN\_DATA\_WRAPPERS.
- 2) Without Feature M004, “Foreign data support”, conforming SQL language shall not reference INFORMATION\_SCHEMA . FOREIGN\_DATA\_WRAPPERS.

## 24.6 FOREIGN\_SERVER\_OPTIONS view

### Function

Identify the options specified for foreign servers that are defined in this catalog.

### Definition

```
CREATE VIEW FOREIGN_SERVER_OPTIONS AS
 SELECT FOREIGN_SERVER_CATALOG, FOREIGN_SERVER_NAME,
 OPTION_NAME, OPTION_VALUE
 FROM DEFINITION_SCHEMA.FOREIGN_SERVER_OPTIONS SO
 WHERE (SO.FOREIGN_SERVER_CATALOG, ' ', SO.FOREIGN_SERVER_NAME)
 IN (SELECT UP.OBJECT_CATALOG, UP.OBJECT_SCHEMA, UP.OBJECT_NAME
 FROM DEFINITION_SCHEMA.USAGE_PRIVILEGES AS UP
 WHERE (UP.GRANTEE IN
 ('PUBLIC', CURRENT_USER)
 OR
 UP.GRANTEE IN
 (SELECT ROLE_NAME
 FROM ENABLED_ROLES))))
 AND
 SO.FOREIGN_SERVER_CATALOG
 = (SELECT CATALOG_NAME
 FROM INFORMATION_SCHEMA.CATALOG_NAME) ;

GRANT SELECT ON TABLE FOREIGN_SERVER_OPTIONS
 TO PUBLIC WITH GRANT OPTION;
```

### Conformance Rules

- 1) Without Feature F391, “Long identifiers”, conforming SQL language shall not reference INFORMATION\_SCHEMA . FOREIGN\_SERVER\_OPTIONS.
- 2) Without Feature M004, “Foreign data support”, conforming SQL language shall not reference INFORMATION\_SCHEMA . FOREIGN\_SERVER\_OPTIONS.

## 24.7 FOREIGN\_SERVERS view

### Function

Identify the foreign servers defined in this catalog.

### Definition

```
CREATE VIEW FOREIGN_SERVERS AS
 SELECT FOREIGN_SERVER_CATALOG, FOREIGN_SERVER_NAME,
 FOREIGN_DATA_WRAPPER_CATALOG, FOREIGN_DATA_WRAPPER_NAME,
 FOREIGN_SERVER_TYPE, FOREIGN_SERVER_VERSION,
 AUTHORIZATION_IDENTIFIER
 FROM DEFINITION_SCHEMA.FOREIGN_SERVERS FS
 WHERE (FS.FOREIGN_SERVER_CATALOG, ' ', FS.FOREIGN_SERVER_NAME)
 IN (SELECT UP.OBJECT_CATALOG, UP.OBJECT_SCHEMA, UP.OBJECT_NAME
 FROM DEFINITION_SCHEMA.USAGE_PRIVILEGES AS UP
 WHERE (UP.GRANTEE IN
 ('PUBLIC', CURRENT_USER)
 OR
 UP.GRANTEE IN
 (SELECT ROLE_NAME
 FROM ENABLED_ROLES))))
 AND
 FS.FOREIGN_SERVER_CATALOG
 = (SELECT CATALOG_NAME
 FROM INFORMATION_SCHEMA.CATALOG_NAME) ;

GRANT SELECT ON TABLE FOREIGN_SERVERS
 TO PUBLIC WITH GRANT OPTION;
```

### Conformance Rules

- 1) Without Feature F391, “Long identifiers”, conforming SQL language shall not reference INFORMATION\_SCHEMA . FOREIGN\_SERVERS.
- 2) Without Feature M004, “Foreign data support”, conforming SQL language shall not reference INFORMATION\_SCHEMA . FOREIGN\_SERVERS.

## 24.8 FOREIGN\_TABLE\_OPTIONS view

### Function

Identify the options specified for foreign tables that are defined in this catalog.

### Definition

```
CREATE VIEW FOREIGN_TABLE_OPTIONS AS
 SELECT FOREIGN_TABLE_CATALOG, FOREIGN_TABLE_SCHEMA, FOREIGN_TABLE_NAME,
 OPTION_NAME, OPTION_VALUE
 FROM DEFINITION_SCHEMA.FOREIGN_TABLE_OPTIONS
 WHERE (FOREIGN_TABLE_CATALOG, FOREIGN_TABLE_SCHEMA, FOREIGN_TABLE_NAME) IN
 (SELECT TABLE_CATALOG, TABLE_SCHEMA, TABLE_NAME
 FROM DEFINITION_SCHEMA.TABLE_PRIVILEGES
 WHERE GRANTEE IN
 ('PUBLIC', CURRENT_USER)
 UNION
 SELECT TABLE_CATALOG, TABLE_SCHEMA, TABLE_NAME
 FROM DEFINITION_SCHEMA.COLUMN_PRIVILEGES
 WHERE GRANTEE IN
 ('PUBLIC', CURRENT_USER))
 AND
 FOREIGN_TABLE_CATALOG
 = (SELECT CATALOG_NAME
 FROM INFORMATION_SCHEMA.CATALOG_NAME) ;

GRANT SELECT ON TABLE FOREIGN_TABLE_OPTIONS
 TO PUBLIC WITH GRANT OPTION;
```

### Conformance Rules

- 1) Without Feature F391, “Long identifiers”, conforming SQL language shall not reference INFORMATION\_SCHEMA . FOREIGN\_TABLE\_OPTIONS.
- 2) Without Feature M004, “Foreign data support”, conforming SQL language shall not reference INFORMATION\_SCHEMA . FOREIGN\_TABLE\_OPTIONS.

## 24.9 FOREIGN\_TABLES view

### Function

Identify the foreign tables that are defined in this catalog.

### Definition

```
CREATE VIEW FOREIGN_TABLES AS
 SELECT FOREIGN_TABLE_CATALOG, FOREIGN_TABLE_SCHEMA, FOREIGN_TABLE_NAME,
 FOREIGN_SERVER_CATALOG, FOREIGN_SERVER_NAME
 FROM DEFINITION_SCHEMA.FOREIGN_TABLES
 WHERE (FOREIGN_TABLE_CATALOG, FOREIGN_TABLE_SCHEMA, FOREIGN_TABLE_NAME) IN
 (SELECT TABLE_CATALOG, TABLE_SCHEMA, TABLE_NAME
 FROM DEFINITION_SCHEMA.TABLE_PRIVILEGES
 WHERE GRANTEE IN
 ('PUBLIC', CURRENT_USER)
 UNION
 SELECT TABLE_CATALOG, TABLE_SCHEMA, TABLE_NAME
 FROM DEFINITION_SCHEMA.COLUMN_PRIVILEGES
 WHERE GRANTEE IN
 ('PUBLIC', CURRENT_USER))
 AND
 FOREIGN_TABLE_CATALOG
 = (SELECT CATALOG_NAME
 FROM INFORMATION_SCHEMA.CATALOG_NAME) ;

GRANT SELECT ON TABLE FOREIGN_TABLES
 TO PUBLIC WITH GRANT OPTION;
```

### Conformance Rules

- 1) Without Feature F391, “Long identifiers”, conforming SQL language shall not reference INFORMATION\_SCHEMA . FOREIGN\_TABLES.
- 2) Without Feature M004, “Foreign data support”, conforming SQL language shall not reference INFORMATION\_SCHEMA . FOREIGN\_TABLES.



## 24.10 ROUTINE\_MAPPING\_OPTIONS view

### Function

Identify the options specified for routine mappings that are defined in this catalog.

### Definition

```
CREATE VIEW ROUTINE_MAPPING_OPTIONS AS
 SELECT ROUTINE_MAPPING_NAME, OPTION_NAME, OPTION_VALUE
 FROM DEFINITION_SCHEMA.ROUTINE_MAPPING_OPTIONS ;
GRANT SELECT ON TABLE ROUTINE_MAPPING_OPTIONS
 TO PUBLIC WITH GRANT OPTION;
```

### Conformance Rules

- 1) Without Feature F391, “Long identifiers”, conforming SQL language shall not reference INFORMATION\_SCHEMA . ROUTINE\_MAPPING\_OPTIONS.
- 2) Without Feature M004, “Foreign data support”, conforming SQL language shall not reference INFORMATION\_SCHEMA . ROUTINE\_MAPPING\_OPTIONS.

## 24.11 ROUTINE\_MAPPINGS view

### Function

Identify the routine mappings that are defined in this catalog.

### Definition

```
CREATE VIEW ROUTINE_MAPPINGS AS
 SELECT ROUTINE_MAPPING_NAME, SPECIFIC_CATALOG,
 SPECIFIC_SCHEMA, SPECIFIC_NAME,
 FOREIGN_SERVER_CATALOG, FOREIGN_SERVER_NAME
 FROM DEFINITION_SCHEMA.ROUTINE_MAPPINGS ;
```

```
GRANT SELECT ON TABLE ROUTINE_MAPPINGS
 TO PUBLIC WITH GRANT OPTION;
```

### Conformance Rules

- 1) Without Feature F391, “Long identifiers”, conforming SQL language shall not reference INFORMATION\_SCHEMA . ROUTINE\_MAPPINGS.
- 2) Without Feature M004, “Foreign data support”, conforming SQL language shall not reference INFORMATION\_SCHEMA . ROUTINE\_MAPPINGS.

## 24.12 USER\_MAPPING\_OPTIONS view

### Function

Identify the options specified for user mappings that are defined in this catalog.

### Definition

```
CREATE VIEW USER_MAPPING_OPTIONS AS
 SELECT AUTHORIZATION_IDENTIFIER,
 FOREIGN_SERVER_CATALOG, FOREIGN_SERVER_NAME,
 OPTION_NAME, OPTION_VALUE
 FROM DEFINITION_SCHEMA.USER_MAPPING_OPTIONS ;
```

```
GRANT SELECT ON TABLE USER_MAPPING_OPTIONS
 TO PUBLIC WITH GRANT OPTION;
```

### Conformance Rules

- 1) Without Feature F391, “Long identifiers”, conforming SQL language shall not reference INFORMATION\_SCHEMA . USER\_MAPPING\_OPTIONS.
- 2) Without Feature M004, “Foreign data support”, conforming SQL language shall not reference INFORMATION\_SCHEMA . USER\_MAPPING\_OPTIONS.

## 24.13 USER\_MAPPINGS view

### Function

Identify the user mappings that are defined in this catalog.

### Definition

```
CREATE VIEW USER_MAPPINGS AS
 SELECT AUTHORIZATION_IDENTIFIER,
 FOREIGN_SERVER_CATALOG, FOREIGN_SERVER_NAME
 FROM DEFINITION_SCHEMA.USER_MAPPINGS ;
```

```
GRANT SELECT ON TABLE USER_MAPPINGS
 TO PUBLIC WITH GRANT OPTION;
```

### Conformance Rules

- 1) Without Feature F391, “Long identifiers”, conforming SQL language shall not reference INFORMATION\_SCHEMA . USER\_MAPPINGS.
- 2) Without Feature M004, “Foreign data support”, conforming SQL language shall not reference INFORMATION\_SCHEMA . USER\_MAPPINGS.

## 24.14 Short name views

*This Subclause modifies Subclause 5.78, “Short name views”, in ISO/IEC 9075-11.*

### Function

Provide alternative views that use only identifiers that do not require Feature F391, “Long identifiers”.

### Definition

Replace ATTRIBUTES\_S with the following

```
CREATE VIEW ATTRIBUTES_S
(UDT_CATALOG, UDT_SCHEMA, UDT_NAME,
 ATTRIBUTE_NAME, ORDINAL_POSITION, ATTRIBUTE_DEFAULT,
 IS_NULLABLE, DATA_TYPE, CHAR_MAX_LENGTH,
 CHAR_OCTET_LENGTH, CHAR_SET_CATALOG, CHAR_SET_SCHEMA,
 CHARACTER_SET_NAME, COLLATION_CATALOG, COLLATION_SCHEMA,
 COLLATION_NAME, NUMERIC_PRECISION, NUMERIC_PREC_RADIX,
 NUMERIC_SCALE, DATETIME_PRECISION, INTERVAL_TYPE,
 INTERVAL_PRECISION, DOMAIN_CATALOG, DOMAIN_SCHEMA,
 DOMAIN_NAME, ATT_UDT_CAT, ATT_UDT_SCHEMA,
 ATT_UDT_NAME, SCOPE_CATALOG, SCOPE_SCHEMA,
 SCOPE_NAME, MAX_CARDINALITY, DTD_IDENTIFIER,
 IS_DERIVED_REF_ATT, DL_LINK_CONTROL, DL_INTEGRITY,
 DL_R_PERMISSION, DL_W_PERMISSION, DL_RECOVERY,
 DATALINK_UNLINK) AS
SELECT UDT_CATALOG, UDT_SCHEMA, UDT_NAME,
 ATTRIBUTE_NAME, ORDINAL_POSITION, COLUMN_DEFAULT,
 IS_NULLABLE, DATA_TYPE, CHARACTER_MAXIMUM_LENGTH,
 CHARACTER_OCTET_LENGTH, CHARACTER_SET_CATALOG, CHARACTER_SET_SCHEMA,
 CHARACTER_SET_NAME, COLLATION_CATALOG, COLLATION_SCHEMA,
 COLLATION_NAME, NUMERIC_PRECISION, NUMERIC_PRECISION_RADIX,
 NUMERIC_SCALE, DATETIME_PRECISION, INTERVAL_TYPE,
 INTERVAL_PRECISION, DOMAIN_CATALOG, DOMAIN_SCHEMA,
 DOMAIN_NAME, ATTRIBUTE_UDT_CATALOG, ATTRIBUTE_UDT_SCHEMA,
 ATTRIBUTE_UDT_NAME, SCOPE_CATALOG, SCOPE_SCHEMA,
 SCOPE_NAME, MAXIMUM_CARDINALITY, DTD_IDENTIFIER, CHECK_REFERENCES,
 IS_DERIVED_REFERENCE_ATTRIBUTE, DATALINK_LINK_CONTROL, DATALINK_INTEGRITY,
 DATALINK_READ_PERMISSION, DATALINK_WRITE_PERMISSION, DATALINK_RECOVERY,
 DATALINK_UNLINK
FROM INFORMATION_SCHEMA.ATTRIBUTES;

GRANT SELECT ON TABLE ATTRIBUTES_S
TO PUBLIC WITH GRANT OPTION;
```

Replace COLUMNS\_S with the following

```
CREATE VIEW COLUMNS_S
(TABLE_CATALOG, TABLE_SCHEMA, TABLE_NAME,
 COLUMN_NAME, ORDINAL_POSITION, COLUMN_DEFAULT,
 IS_NULLABLE, DATA_TYPE, CHAR_MAX_LENGTH,
```

```

CHAR_OCTET_LENGTH, NUMERIC_PRECISION, NUMERIC_PREC_RADIX,
NUMERIC_SCALE, DATETIME_PRECISION, INTERVAL_TYPE,
INTERVAL_PRECISION, CHAR_SET_CATALOG, CHAR_SET_SCHEMA,
CHARACTER_SET_NAME, COLLATION_CATALOG, COLLATION_SCHEMA,
COLLATION_NAME, DOMAIN_CATALOG, DOMAIN_SCHEMA,
DOMAIN_NAME, UDT_CATALOG, UDT_SCHEMA,
UDT_NAME, SCOPE_CATALOG, SCOPE_SCHEMA,
SCOPE_NAME, MAX_CARDINALITY, DTD_IDENTIFIER,
IS_SELF_REF, IS_IDENTITY, ID_GENERATION,
ID_START, ID_INCREMENT, DL_LINK_CONTROL,
DL_INTEGRITY, DL_R_PERMISSION, DL_W_PERMISSION,
DL_RECOVERY, DL_UNLINK) AS
SELECT TABLE_CATALOG, TABLE_SCHEMA, TABLE_NAME,
COLUMN_NAME, ORDINAL_POSITION, COLUMN_DEFAULT,
IS_NULLABLE, DATA_TYPE, CHARACTER_MAXIMUM_LENGTH,
CHARACTER_OCTET_LENGTH, NUMERIC_PRECISION, NUMERIC_PRECISION_RADIX,
NUMERIC_SCALE, DATETIME_PRECISION, INTERVAL_TYPE,
INTERVAL_PRECISION, CHARACTER_SET_CATALOG, CHARACTER_SET_SCHEMA,
CHARACTER_SET_NAME, COLLATION_CATALOG, COLLATION_SCHEMA,
COLLATION_NAME, DOMAIN_CATALOG, DOMAIN_SCHEMA,
DOMAIN_NAME, UDT_CATALOG, UDT_SCHEMA,
UDT_NAME, SCOPE_CATALOG, SCOPE_SCHEMA,
SCOPE_NAME, MAXIMUM_CARDINALITY, DTD_IDENTIFIER,
IS_SELF_REFERENCING, IS_IDENTITY, IDENTITY_GENERATION,
IDENTITY_START, IDENTITY_INCREMENT,
DATALINK_LINK_CONTROL, DATALINK_INTEGRITY, DATALINK_READ_PERMISSION,
DATALINK_WRITE_PERMISSION, DATALINK_RECOVERY, DATALINK_UNLINK
FROM INFORMATION_SCHEMA.COLUMNS ;

```

```

GRANT SELECT ON TABLE COLUMNS_S
TO PUBLIC WITH GRANT OPTION ;

```

Insert the following new short-name views

```

CREATE VIEW FDW_OPTIONS_S
(FDW_CATALOG, FDW_NAME, OPTION_NAME,
 OPTION_VALUE) AS
SELECT FOREIGN_DATA_WRAPPER_CATALOG, FOREIGN_DATA_WRAPPER_NAME,
 OPTION_NAME, OPTION_VALUE
FROM INFORMATION_SCHEMA.FOREIGN_DATA_WRAPPER_OPTIONS ;

```

```

GRANT SELECT ON TABLE FDW_OPTIONS_S
TO PUBLIC WITH GRANT OPTION ;

```

```

CREATE VIEW FD_WRAPPERS_S
(FDW_CATALOG, FDW_NAME, AUTHORIZATION_ID,
 LIBRARY_NAME, FDW_LANGUAGE) AS
SELECT FOREIGN_DATA_WRAPPER_CATALOG, FOREIGN_DATA_WRAPPER_NAME,
 AUTHORIZATION_IDENTIFIER, LIBRARY_NAME,
 FOREIGN_DATA_WRAPPER_LANGUAGE
FROM INFORMATION_SCHEMA.FOREIGN_DATA_WRAPPERS ;

```

```

GRANT SELECT ON TABLE FD_WRAPPERS_S
TO PUBLIC WITH GRANT OPTION ;

```

## CD ISO/IEC 9075-9:2007 (E)

### 24.14 Short name views

```
CREATE VIEW FS_OPTIONS_S
 (FS_CATALOG, FS_NAME, OPTION_NAME,
 OPTION_VALUE) AS
SELECT FOREIGN_SERVER_CATALOG, FOREIGN_SERVER_NAME,
 OPTION_NAME, OPTION_VALUE
FROM INFORMATION_SCHEMA.FOREIGN_SERVER_OPTIONS ;
```

```
GRANT SELECT ON TABLE FS_OPTIONS_S
 TO PUBLIC WITH GRANT OPTION ;
```

```
CREATE VIEW FT_OPTIONS_S
 (FT_CATALOG, FT_SCHEMA, FOREIGN_TABLE_NAME,
 OPTION_NAME, OPTION_VALUE) AS
SELECT FOREIGN_TABLE_CATALOG, FOREIGN_TABLE_SCHEMA, FOREIGN_TABLE_NAME,
 OPTION_NAME, OPTION_VALUE
FROM INFORMATION_SCHEMA.FOREIGN_TABLE_OPTIONS ;
```

```
GRANT SELECT ON TABLE FT_OPTIONS_S
 TO PUBLIC WITH GRANT OPTION ;
```

```
CREATE VIEW FOREIGN_SERVERS_S
 (FS_CATALOG, FS_NAME, FDW_CATALOG,
 FDW_NAME, FS_TYPE, FS_VERSION,
 AUTHORIZATION_ID) AS
SELECT FOREIGN_SERVER_CATALOG, FOREIGN_SERVER_NAME, FOREIGN_DATA_WRAPPER_CATALOG,
 FOREIGN_DATA_WRAPPER_NAME, FOREIGN_SERVER_TYPE, FOREIGN_SERVER_VERSION,
 AUTHORIZATION_IDENTIFIER
FROM INFORMATION_SCHEMA.FOREIGN_SERVERS ;
```

```
GRANT SELECT ON TABLE FOREIGN_SERVERS_S
 TO PUBLIC WITH GRANT OPTION ;
```

```
CREATE VIEW FOREIGN_TABLES_S
 (FT_CATALOG, FT_SCHEMA, FOREIGN_TABLE_NAME,
 FS_CATALOG, FS_NAME) AS
SELECT FOREIGN_TABLE_CATALOG, FOREIGN_TABLE_SCHEMA, FOREIGN_TABLE_NAME,
 FOREIGN_SERVER_CATALOG, FOREIGN_SERVER_NAME
FROM INFORMATION_SCHEMA.FOREIGN_TABLES ;
```

```
GRANT SELECT ON TABLE FOREIGN_TABLES_S
 TO PUBLIC WITH GRANT OPTION ;
```

```
CREATE VIEW ROUT_MAP_OPTIONS_S
 (RM_NAME, OPTION_NAME, OPTION_VALUE) AS
SELECT ROUTINE_MAPPING_NAME, OPTION_NAME, OPTION_VALUE
FROM INFORMATION_SCHEMA.ROUTINE_MAPPING_OPTIONS ;
```

```
GRANT SELECT ON TABLE ROUT_MAP_OPTIONS_S
 TO PUBLIC WITH GRANT OPTION ;
```

```
CREATE VIEW ROUTINE_MAPPINGS_S
```

```
 (RM_NAME, SPECIFIC_CATALOG, SPECIFIC_SCHEMA,
 SPECIFIC_NAME, FS_CATALOG, FS_NAME) AS
SELECT ROUTINE_MAPPING_NAME, SPECIFIC_CATALOG,
 SPECIFIC_SCHEMA, SPECIFIC_NAME,
 FOREIGN_SERVER_CATALOG, FOREIGN_SERVER_NAME
FROM INFORMATION_SCHEMA.ROUTINE_MAPPINGS ;
```

```
GRANT SELECT ON TABLE ROUTINE_MAPPINGS_S
TO PUBLIC WITH GRANT OPTION ;
```

```
CREATE VIEW USER_MAP_OPTIONS_S
 (AUTH_ID, FS_CATALOG, FS_NAME,
 OPTION_NAME, OPTION_VALUE) AS
SELECT AUTHORIZATION_IDENTIFIER, FOREIGN_SERVER_CATALOG, FOREIGN_SERVER_NAME,
 OPTION_NAME, OPTION_VALUE
FROM INFORMATION_SCHEMA.USER_MAPPING_OPTIONS ;
```

```
GRANT SELECT ON TABLE USER_MAP_OPTIONS_S
TO PUBLIC WITH GRANT OPTION ;
```

```
CREATE VIEW USER_MAPPINGS_S
 (AUTH_ID, FS_CATALOG, FS_NAME) AS
SELECT AUTHORIZATION_IDENTIFIER, FOREIGN_SERVER_CATALOG, FOREIGN_SERVER_NAME
FROM INFORMATION_SCHEMA.USER_MAPPINGS ;
```

```
GRANT SELECT ON TABLE USER_MAPPINGS_S
TO PUBLIC WITH GRANT OPTION ;
```

## Conformance Rules

- 1) Without Feature M001, “Datalinks”, conforming SQL language shall not reference INFORMATION\_SCHEMA . ATTRIBUTES\_S . DATALINK\_CONTROL.
- 2) Without Feature M001, “Datalinks”, conforming SQL language shall not reference INFORMATION\_SCHEMA . ATTRIBUTES\_S . DL\_INTEGRITY.
- 3) Without Feature M001, “Datalinks”, conforming SQL language shall not reference INFORMATION\_SCHEMA . ATTRIBUTES\_S . DL\_R\_PERMISSION.
- 4) Without Feature M001, “Datalinks”, conforming SQL language shall not reference INFORMATION\_SCHEMA . ATTRIBUTES\_S . DL\_RECOVERY.
- 5) Without Feature M001, “Datalinks”, conforming SQL language shall not reference INFORMATION\_SCHEMA . ATTRIBUTES\_S . DL\_W\_PERMISSION.
- 6) Without Feature M001, “Datalinks”, conforming SQL language shall not reference INFORMATION\_SCHEMA . ATTRIBUTES\_S . DATALINK\_UNLINK.
- 7) Without Feature M001, “Datalinks”, conforming SQL language shall not reference INFORMATION\_SCHEMA . COLUMNS\_S . DATALINK\_CONTROL.
- 8) Without Feature M001, “Datalinks”, conforming SQL language shall not reference INFORMATION\_SCHEMA . COLUMNS\_S . DL\_INTEGRITY.



**24.14 Short name views**

- 9) Without Feature M001, “Datalinks”, conforming SQL language shall not reference INFORMATION\_SCHEMA . COLUMNS\_S . DL\_R\_PERMISSION.
- 10) Without Feature M001, “Datalinks”, conforming SQL language shall not reference INFORMATION\_SCHEMA . COLUMNS\_S . DL\_RECOVERY.
- 11) Without Feature M001, “Datalinks”, conforming SQL language shall not reference INFORMATION\_SCHEMA . COLUMNS\_S . DL\_W\_PERMISSION.
- 12) Without Feature M001, “Datalinks”, conforming SQL language shall not reference INFORMATION\_SCHEMA . COLUMNS\_S . DATALINK\_UNLINK.
- 13) Without Feature M004, “Foreign data support”, conforming SQL language shall not reference INFORMATION\_SCHEMA . ATTRIBUTES\_S.
- 14) Without Feature M004, “Foreign data support”, conforming SQL language shall not reference INFORMATION\_SCHEMA . COLUMNS\_S.
- 15) Without Feature M004, “Foreign data support”, conforming SQL language shall not reference INFORMATION\_SCHEMA . FDW\_OPTIONS\_S.
- 16) Without Feature M004, “Foreign data support”, conforming SQL language shall not reference INFORMATION\_SCHEMA . FD\_WRAPPERS\_S.
- 17) Without Feature M004, “Foreign data support”, conforming SQL language shall not reference INFORMATION\_SCHEMA . FS\_OPTIONS\_S.
- 18) Without Feature M004, “Foreign data support”, conforming SQL language shall not reference INFORMATION\_SCHEMA . FT\_OPTIONS\_S.
- 19) Without Feature M004, “Foreign data support”, conforming SQL language shall not reference INFORMATION\_SCHEMA . FOREIGN\_SERVERS\_S.
- 20) Without Feature M004, “Foreign data support”, conforming SQL language shall not reference INFORMATION\_SCHEMA . FOREIGN\_TABLES\_S.
- 21) Without Feature M004, “Foreign data support”, conforming SQL language shall not reference INFORMATION\_SCHEMA . ROUT\_MAP\_OPTIONS\_S.
- 22) Without Feature M004, “Foreign data support”, conforming SQL language shall not reference INFORMATION\_SCHEMA . ROUTINE\_MAPPINGS\_S.
- 23) Without Feature M004, “Foreign data support”, conforming SQL language shall not reference INFORMATION\_SCHEMA . USER\_MAP\_OPTIONS\_S.
- 24) Without Feature M004, “Foreign data support”, conforming SQL language shall not reference INFORMATION\_SCHEMA . USER\_MAPPINGS\_S.

## 25 Definition Schema

*This Clause modifies Clause 6, “Definition Schema”, in ISO/IEC 9075-11.*

### 25.1 COLUMN\_OPTIONS base table

#### Function

The COLUMN\_OPTIONS base table has one row for each option specified for each column.

#### Definition

```
CREATE TABLE COLUMN_OPTIONS (
 TABLE_CATALOG INFORMATION_SCHEMA.SQL_IDENTIFIER,
 TABLE_SCHEMA INFORMATION_SCHEMA.SQL_IDENTIFIER,
 TABLE_NAME INFORMATION_SCHEMA.SQL_IDENTIFIER,
 COLUMN_NAME INFORMATION_SCHEMA.SQL_IDENTIFIER,
 OPTION_NAME INFORMATION_SCHEMA.SQL_IDENTIFIER,
 OPTION_VALUE INFORMATION_SCHEMA.CHARACTER_DATA,
 CONSTRAINT COLUMN_OPTIONS_PRIMARY_KEY
 PRIMARY KEY (TABLE_CATALOG, TABLE_SCHEMA, TABLE_NAME,
 COLUMN_NAME, OPTION_NAME),
 CONSTRAINT COLUMN_OPTIONS_FOREIGN_KEY_COLUMNS
 FOREIGN KEY (TABLE_CATALOG, TABLE_SCHEMA, TABLE_NAME, COLUMN_NAME)
 REFERENCES COLUMNS
)
```

#### Description

- 1) The values of TABLE\_CATALOG, TABLE\_SCHEMA, TABLE\_NAME, and COLUMN\_NAME are the catalog name, unqualified schema name, qualified identifier, and identifier of the <column name> of the column whose option is being described.
- 2) The value of OPTION\_NAME identifies the option being described.
- 3) The value of OPTION\_VALUE is the value specified for the option being described. The value of OPTION\_VALUE is the null value if no value for the option being described was specified.

## 25.2 DATA\_TYPE\_DESCRIPTOR base table

*This Subclause modifies Subclause 6.21, “DATA\_TYPE\_DESCRIPTOR base table”, in ISO/IEC 9075-11.*

### Function

The DATA\_TYPE\_DESCRIPTOR table has one row for each domain, one row for each column (in each table) and for each attribute (in each structured type) that is defined as having a data type rather than a domain, one row for each distinct type, one row for the result type of each SQL parameter of each SQL-invoked routine, one row for the result type of each method specification, one row for each parameter of each method specification, and one row for each structured type whose associated reference type has a user-defined representation. It effectively contains a representation of the data type descriptors.

### Definition

Add the following <column definition>s to the end of <column definition>s in the <table definition>:

|                           |                                    |
|---------------------------|------------------------------------|
| DATALINK_LINK_CONTROL     | INFORMATION_SCHEMA.YES_OR_NO,      |
| DATALINK_INTEGRITY        | INFORMATION_SCHEMA.CHARACTER_DATA, |
| DATALINK_READ_PERMISSION  | INFORMATION_SCHEMA.CHARACTER_DATA, |
| DATALINK_WRITE_PERMISSION | INFORMATION_SCHEMA.CHARACTER_DATA, |
| DATALINK_RECOVERY         | INFORMATION_SCHEMA.YES_OR_NO,      |
| DATALINK_UNLINK           | INFORMATION_SCHEMA.CHARACTER_DATA, |

Replace constraint DATA\_TYPE\_DESCRIPTOR\_DATA\_TYPE\_CHECK\_COMBINATIONS with

```
CONSTRAINT DATA_TYPE_DESCRIPTOR_DATA_TYPE_CHECK_COMBINATIONS
CHECK ((DATA_TYPE IN
 ('CHARACTER', 'CHARACTER VARYING', 'CHARACTER LARGE OBJECT')
 AND
 (CHARACTER_MAXIMUM_LENGTH, CHARACTER_OCTET_LENGTH,
 COLLATION_CATALOG, COLLATION_SCHEMA, COLLATION_NAME) IS NOT NULL
 AND
 (NUMERIC_PRECISION, NUMERIC_PRECISION_RADIX,
 NUMERIC_SCALE, DATETIME_PRECISION,
 USER_DEFINED_TYPE_CATALOG, USER_DEFINED_TYPE_SCHEMA,
 USER_DEFINED_TYPE_NAME) IS NULL
 AND
 (INTERVAL_TYPE, INTERVAL_PRECISION) IS NULL
 AND
 (SCOPE_CATALOG, SCOPE_SCHEMA, SCOPE_NAME) IS NULL
 AND
 MAXIMUM_CARDINALITY IS NULL)
 OR
 (DATA_TYPE IN
 ('BINARY LARGE OBJECT')
 AND
 (CHARACTER_MAXIMUM_LENGTH, CHARACTER_OCTET_LENGTH)
 IS NOT NULL
 AND
 (COLLATION_CATALOG, COLLATION_SCHEMA, COLLATION_NAME,
 NUMERIC_PRECISION, NUMERIC_PRECISION_RADIX,
```

**CD ISO/IEC 9075-9:2007 (E)**  
**25.2 DATA\_TYPE\_DESCRIPTOR base table**

```
 NUMERIC_SCALE, DATETIME_PRECISION,
 USER_DEFINED_TYPE_CATALOG, USER_DEFINED_TYPE_SCHEMA,
 USER_DEFINED_TYPE_NAME) IS NULL
AND
 (INTERVAL_TYPE, INTERVAL_PRECISION) IS NULL
AND
 (SCOPE_CATALOG, SCOPE_SCHEMA, SCOPE_NAME) IS NULL
AND
 MAXIMUM_CARDINALITY IS NULL)
OR
 (DATA_TYPE IN
 ('SMALLINT', 'INTEGER', 'BIGINT')
 AND
 (CHARACTER_MAXIMUM_LENGTH, CHARACTER_OCTET_LENGTH,
 COLLATION_CATALOG, COLLATION_SCHEMA, COLLATION_NAME) IS NULL
 AND
 NUMERIC_PRECISION_RADIX IN
 (2, 10)
 AND
 NUMERIC_PRECISION IS NOT NULL
 AND
 NUMERIC_SCALE = 0
 AND
 DATETIME_PRECISION IS NULL
 AND
 (INTERVAL_TYPE, INTERVAL_PRECISION) IS NULL
 AND
 (SCOPE_CATALOG, SCOPE_SCHEMA, SCOPE_NAME) IS NULL
 AND
 MAXIMUM_CARDINALITY IS NULL)
OR
 (DATA_TYPE IN
 ('NUMERIC', 'DECIMAL')
 AND
 (CHARACTER_MAXIMUM_LENGTH, CHARACTER_OCTET_LENGTH,
 COLLATION_CATALOG, COLLATION_SCHEMA, COLLATION_NAME) IS NULL
 AND
 NUMERIC_PRECISION_RADIX = 10
 AND
 (NUMERIC_PRECISION, NUMERIC_SCALE) IS NOT NULL
 AND
 DATETIME_PRECISION IS NULL
 AND
 (INTERVAL_TYPE, INTERVAL_PRECISION) IS NULL
 AND
 (SCOPE_CATALOG, SCOPE_SCHEMA, SCOPE_NAME) IS NULL
 AND
 MAXIMUM_CARDINALITY IS NULL)
OR
 (DATA_TYPE IN
 ('REAL', 'DOUBLE PRECISION', 'FLOAT')
 AND
 (CHARACTER_MAXIMUM_LENGTH, CHARACTER_OCTET_LENGTH,
 COLLATION_CATALOG, COLLATION_SCHEMA, COLLATION_NAME) IS NULL
 AND
 NUMERIC_PRECISION IS NOT NULL
 AND
```

**CD ISO/IEC 9075-9:2007 (E)**  
**25.2 DATA\_TYPE\_DESCRIPTOR base table**

```
 NUMERIC_PRECISION_RADIX = 2
AND
 NUMERIC_SCALE IS NULL
AND
 DATETIME_PRECISION IS NULL
AND
 (USER_DEFINED_TYPE_CATALOG, USER_DEFINED_TYPE_SCHEMA,
 USER_DEFINED_TYPE_NAME) IS NULL
AND
 (INTERVAL_TYPE, INTERVAL_PRECISION) IS NULL
AND
 (SCOPE_CATALOG, SCOPE_SCHEMA, SCOPE_NAME) IS NULL
AND
 MAXIMUM_CARDINALITY IS NULL)
OR
 (DATA_TYPE IN
 ('DATE', 'TIME', 'TIMESTAMP',
 'TIME WITH TIME ZONE', 'TIMESTAMP WITH TIME ZONE')
AND
 (CHARACTER_MAXIMUM_LENGTH, CHARACTER_OCTET_LENGTH,
 COLLATION_CATALOG, COLLATION_SCHEMA, COLLATION_NAME) IS NULL
AND
 (NUMERIC_PRECISION, NUMERIC_PRECISION_RADIX) IS NOT NULL
AND
 NUMERIC_SCALE IS NULL
AND
 DATETIME_PRECISION IS NOT NULL
AND
 (USER_DEFINED_TYPE_CATALOG, USER_DEFINED_TYPE_SCHEMA,
 USER_DEFINED_TYPE_NAME) IS NULL
AND
 (INTERVAL_TYPE, INTERVAL_PRECISION) IS NULL
AND
 (SCOPE_CATALOG, SCOPE_SCHEMA, SCOPE_NAME) IS NULL
AND
 MAXIMUM_CARDINALITY IS NULL)
OR
 (DATA_TYPE = 'INTERVAL'
AND
 (CHARACTER_MAXIMUM_LENGTH, CHARACTER_OCTET_LENGTH,
 COLLATION_CATALOG, COLLATION_SCHEMA, COLLATION_NAME) IS NULL
AND
 (NUMERIC_PRECISION, NUMERIC_PRECISION_RADIX) IS NOT NULL
AND
 NUMERIC_SCALE IS NULL
AND
 DATETIME_PRECISION IS NOT NULL
AND
 (USER_DEFINED_TYPE_CATALOG, USER_DEFINED_TYPE_SCHEMA,
 USER_DEFINED_TYPE_NAME) IS NULL
AND
 INTERVAL_TYPE IN
 ('YEAR', 'MONTH', 'DAY', 'HOUR', 'MINUTE', 'SECOND',
 'YEAR TO MONTH', 'DAY TO HOUR', 'DAY TO MINUTE',
 'DAY TO SECOND', 'HOUR TO MINUTE',
 'HOUR TO SECOND', 'MINUTE TO SECOND')
AND
```

**CD ISO/IEC 9075-9:2007 (E)**  
**25.2 DATA\_TYPE\_DESCRIPTOR base table**

```
INTERVAL_PRECISION IS NOT NULL
AND
 (SCOPE_CATALOG, SCOPE_SCHEMA, SCOPE_NAME) IS NULL
AND
 MAXIMUM_CARDINALITY IS NULL)
OR
 (DATA_TYPE IN ('BOOLEAN', 'DATALINK')
AND
 (CHARACTER_MAXIMUM_LENGTH, CHARACTER_OCTET_LENGTH,
 COLLATION_CATALOG, COLLATION_SCHEMA, COLLATION_NAME) IS NULL
AND
 (NUMERIC_PRECISION, NUMERIC_PRECISION_RADIX) IS NULL
AND
 NUMERIC_SCALE IS NULL
AND
 DATETIME_PRECISION IS NULL
AND
 (INTERVAL_TYPE, INTERVAL_PRECISION) IS NULL
AND
 (USER_DEFINED_TYPE_CATALOG, USER_DEFINED_TYPE_SCHEMA,
 USER_DEFINED_TYPE_NAME) IS NULL
AND
 (SCOPE_CATALOG, SCOPE_SCHEMA, SCOPE_NAME) IS NULL
AND
 MAXIMUM_CARDINALITY IS NULL)
OR
 (DATA_TYPE = 'USER-DEFINED'
AND
 (NUMERIC_PRECISION, NUMERIC_PRECISION_RADIX,
 NUMERIC_SCALE, DATETIME_PRECISION, CHARACTER_OCTET_LENGTH,
 CHARACTER_MAXIMUM_LENGTH, INTERVAL_TYPE, INTERVAL_PRECISION,
 SCOPE_CATALOG, SCOPE_SCHEMA, SCOPE_NAME) IS NULL
AND
 (USER_DEFINED_TYPE_CATALOG, USER_DEFINED_TYPE_SCHEMA,
 USER_DEFINED_TYPE_NAME) IS NOT NULL
AND
 MAXIMUM_CARDINALITY IS NULL)
OR
 (DATA_TYPE = 'REF'
AND
 (CHARACTER_MAXIMUM_LENGTH, CHARACTER_OCTET_LENGTH) IS NOT NULL
AND
 (NUMERIC_PRECISION, NUMERIC_PRECISION_RADIX,
 NUMERIC_SCALE, DATETIME_PRECISION,
 INTERVAL_TYPE, INTERVAL_PRECISION) IS NULL
AND
 (USER_DEFINED_TYPE_CATALOG, USER_DEFINED_TYPE_SCHEMA,
 USER_DEFINED_TYPE_NAME) IS NOT NULL
AND
 MAXIMUM_CARDINALITY IS NULL)
OR
 (DATA_TYPE = 'ARRAY'
AND
 (NUMERIC_PRECISION, NUMERIC_PRECISION_RADIX,
 NUMERIC_SCALE, DATETIME_PRECISION, CHARACTER_OCTET_LENGTH,
 CHARACTER_MAXIMUM_LENGTH, INTERVAL_TYPE, INTERVAL_PRECISION)
 IS NULL
```

**CD ISO/IEC 9075-9:2007 (E)**  
**25.2 DATA\_TYPE\_DESCRIPTOR base table**

```
AND
 (USER_DEFINED_TYPE_CATALOG, USER_DEFINED_TYPE_SCHEMA,
 USER_DEFINED_TYPE_NAME) IS NULL
AND
 (SCOPE_CATALOG, SCOPE_SCHEMA, SCOPE_NAME) IS NULL
AND
 MAXIMUM_CARDINALITY IS NOT NULL)
OR
 (DATA_TYPE = 'MULTISET'
 AND
 (NUMERIC_PRECISION, NUMERIC_PRECISION_RADIX,
 NUMERIC_SCALE, DATETIME_PRECISION, CHARACTER_OCTET_LENGTH,
 CHARACTER_MAXIMUM_LENGTH, INTERVAL_TYPE, INTERVAL_PRECISION)
 IS NULL
 AND
 (USER_DEFINED_TYPE_CATALOG, USER_DEFINED_TYPE_SCHEMA,
 USER_DEFINED_TYPE_NAME) IS NULL
 AND
 (SCOPE_CATALOG, SCOPE_SCHEMA, SCOPE_NAME) IS NULL
 AND
 MAXIMUM_CARDINALITY IS NULL)
OR
 (DATA_TYPE = 'ROW'
 AND
 (NUMERIC_PRECISION, NUMERIC_PRECISION_RADIX,
 NUMERIC_SCALE, DATETIME_PRECISION, CHARACTER_OCTET_LENGTH,
 CHARACTER_MAXIMUM_LENGTH, INTERVAL_TYPE, INTERVAL_PRECISION)
 IS NULL
 AND
 (USER_DEFINED_TYPE_CATALOG, USER_DEFINED_TYPE_SCHEMA,
 USER_DEFINED_TYPE_NAME) IS NULL
 AND
 (SCOPE_CATALOG, SCOPE_SCHEMA, SCOPE_NAME) IS NULL
 AND
 MAXIMUM_CARDINALITY IS NULL)
OR
 (DATA_TYPE NOT IN
 ('CHARACTER', 'CHARACTER VARYING', 'CHARACTER LARGE OBJECT',
 'BINARY LARGE OBJECT',
 'NUMERIC', 'DECIMAL', 'SMALLINT', 'INTEGER', 'BIGINT',
 'FLOAT', 'REAL', 'DOUBLE PRECISION',
 'DATE', 'TIME', 'TIMESTAMP',
 'INTERVAL', 'BOOLEAN', 'USER-DEFINED',
 'REF', 'DATALINK',
 'ARRAY', 'MULTISET', 'ROW'))),
```

Insert these constraints

```
CONSTRAINT DATA_TYPE_DESCRIPTOR_DATALINK_INTEGRITY
 CHECK (DATALINK_INTEGRITY IN ('ALL', 'SELECTIVE', 'NONE')),

CONSTRAINT DATA_TYPE_DESCRIPTOR_DATALINK_READ_PERMISSION
 CHECK (DATALINK_READ_PERMISSION IN ('FS', 'DB')),

CONSTRAINT DATA_TYPE_DESCRIPTOR_DATALINK_WRITE_PERMISSION
 CHECK (DATALINK_WRITE_PERMISSION IN
 ('FS', 'BLOCKED',
```

```
'ADMIN REQUIRING TOKEN FOR UPDATE',
'ADMIN NOT REQUIRING TOKEN FOR UPDATE')),

CONSTRAINT DATA_TYPE_DESCRIPTOR_DATALINK_UNLINK
CHECK (DATALINK_UNLINK IN
 ('DELETE', 'RESTORE', 'NONE')),

CONSTRAINT DATA_TYPE_DESCRIPTOR_DATALINK_VALID_COMBINATIONS
CHECK (DATALINK_LINK_CONTROL = 'NO'
 OR
 ((DATALINK_INTEGRITY <> 'SELECTIVE'
 OR
 (DATALINK_READ_PERMISSION = 'FS'
 AND
 DATALINK_WRITE_PERMISSION = 'FS'
 AND
 DATALINK_RECOVERY = 'NO'))
 AND
 (DATALINK_READ_PERMISSION <> 'DB'
 OR
 DATALINK_WRITE_PERMISSION <> 'FS')
 AND
 (DATALINK_WRITE_PERMISSION = 'FS'
 OR
 (DATALINK_INTEGRITY = 'ALL'
 AND
 DATALINK_UNLINK <> 'NONE'))
 AND
 (DATALINK_WRITE_PERMISSION <> 'FS'
 OR
 (DATALINK_READ_PERMISSION = 'FS'
 AND
 DATALINK_RECOVERY = 'NO'
 AND
 DATALINK_UNLINK = 'NONE'))
 AND
 (DATALINK_RECOVERY <> 'YES'
 OR
 DATALINK_WRITE_PERMISSION <> 'FS')
 AND
 (DATALINK_UNLINK <> 'DELETE'
 OR
 DATALINK_READ_PERMISSION = 'DB')))
```

## Description

- 1) Insert this Description If DATA\_TYPE is 'DATALINK', then the data type being described is the datalink type.
- 2) Insert this Description If DATA\_TYPE is not DATALINK, then the values of DATALINK\_LINK\_CONTROL, DATALINK\_INTEGRITY, DATALINK\_READ\_PERMISSION, DATALINK\_WRITE\_PERMISSION, DATALINK\_RECOVERY, and DATALINK\_UNLINK are the null value; otherwise, the values of DATALINK\_LINK\_CONTROL, DATALINK\_INTEGRITY, DATALINK\_READ\_PERMISSION, DATALINK\_WRITE\_PERMISSION, DATALINK\_RECOVERY,



25.2 DATA\_TYPE\_DESCRIPTOR base table

and DATALINK\_UNLINK are the link control, integrity control option, read permission option, write permission option, recovery option, and unlink option, respectively, of the site being described.

- 3) Insert this Description If OBJECT\_TYPE is not 'USER-DEFINED TYPE' or 'TABLE', then the values of DATALINK\_LINK\_CONTROL, DATALINK\_INTEGRITY, DATALINK\_READ\_PERMISSION, DATALINK\_WRITE\_PERMISSION, DATALINK\_RECOVERY, and DATALINK\_UNLINK are the null value; otherwise, the values of DATALINK\_LINK\_CONTROL, DATALINK\_INTEGRITY, DATALINK\_READ\_PERMISSION, DATALINK\_WRITE\_PERMISSION, DATALINK\_RECOVERY, and DATALINK\_UNLINK are the link control, integrity control option, read permission option, write permission option, recovery option, and unlink option, respectively of the site being described.
- 4) Insert this Description The value of DATALINK\_LINK\_CONTROL have the following meanings:

|     |                                                                |
|-----|----------------------------------------------------------------|
| YES | The datalink value at the site is under file link control.     |
| NO  | The datalink value at the site is not under file link control. |

- 5) Insert this Description The value of DATALINK\_INTEGRITY have the following meanings:

|           |                                                                                                                                                         |
|-----------|---------------------------------------------------------------------------------------------------------------------------------------------------------|
| ALL       | The external file corresponding to the datalink value at the site is under the control of the SQL-implementation.                                       |
| SELECTIVE | The external file corresponding to the datalink value at the site is under the control of the SQL-implementation in an implementation-dependent manner. |
| NONE      | The external file corresponding to the datalink value at the site is not under the control of the SQL-implementation.                                   |

- 6) Insert this Description The value of DATALINK\_READ\_PERMISSION have the following meanings:

|    |                                                                                                                                                 |
|----|-------------------------------------------------------------------------------------------------------------------------------------------------|
| FS | The external file corresponding to the datalink value at the site is under the operating system's file programming permissions for read access. |
| DB | The external file corresponding to the datalink value at the site is under the SQL-implementation's control for read access.                    |

- 7) Insert this Description The value of DATALINK\_WRITE\_PERMISSION have the following meanings:

|                                  |                                                                                                                                                                                                                                              |
|----------------------------------|----------------------------------------------------------------------------------------------------------------------------------------------------------------------------------------------------------------------------------------------|
| FS                               | The external file corresponding to the datalink value at the site is under the operating system's file programming permissions for write access.                                                                                             |
| BLOCKED                          | Write access to the external file corresponding to the datalink value at the site is blocked.                                                                                                                                                |
| ADMIN REQUIRING TOKEN FOR UPDATE | Write access to the external file corresponding to the datalink value at the site is under the control of the SQL-server and the datalinker. A write token is needed to update the external file and the site containing the datalink value. |

|                                      |                                                                                                                                                                                                                                                                          |
|--------------------------------------|--------------------------------------------------------------------------------------------------------------------------------------------------------------------------------------------------------------------------------------------------------------------------|
| ADMIN NOT REQUIRING TOKEN FOR UPDATE | Write access to the external file corresponding to the datalink value at the site is under the control of the SQL-server and the datalinker. A write token is needed to update the external file, but it is not needed to update the site containing the datalink value. |
|--------------------------------------|--------------------------------------------------------------------------------------------------------------------------------------------------------------------------------------------------------------------------------------------------------------------------|

8)  The value of DATALINK\_RECOVERY have the following meanings:

|     |                                                                                          |
|-----|------------------------------------------------------------------------------------------|
| YES | The coordinated recovery of SQL-implementation data and external files is supported.     |
| NO  | The coordinated recovery of SQL-implementation data and external files is not supported. |

9)  The value of DATALINK\_UNLINK have the following meanings:

|         |                                                                                                                                                                 |
|---------|-----------------------------------------------------------------------------------------------------------------------------------------------------------------|
| DELETE  | On unlink, the external file corresponding to the datalink value at the site is deleted.                                                                        |
| RESTORE | On unlink, the file attributes of the external file corresponding to the datalink value at the site are restored to those at the time when the file was linked. |
| NONE    | The external file corresponding to the datalink value at the site is not under SQL-implementation control.                                                      |

## 25.3 FOREIGN\_DATA\_WRAPPER\_OPTIONS base table

### Function

The FOREIGN\_DATA\_WRAPPER\_OPTIONS base table has one row for each option specified for each foreign-data wrapper.

### Definition

```
CREATE TABLE FOREIGN_DATA_WRAPPER_OPTIONS (
 FOREIGN_DATA_WRAPPER_CATALOG INFORMATION_SCHEMA.SQL_IDENTIFIER,
 FOREIGN_DATA_WRAPPER_NAME INFORMATION_SCHEMA.SQL_IDENTIFIER,
 OPTION_NAME INFORMATION_SCHEMA.SQL_IDENTIFIER,
 OPTION_VALUE INFORMATION_SCHEMA.SQL_CHARACTER_DATA,
 CONSTRAINT FOREIGN_DATA_WRAPPER_OPTIONS_PRIMARY_KEY
 PRIMARY KEY (FOREIGN_DATA_WRAPPER_CATALOG, FOREIGN_DATA_WRAPPER_NAME,
 OPTION_NAME),
 CONSTRAINT FOREIGN_DATA_WRAPPER_OPTIONS_FOREIGN_KEY_FOREIGN_DATA_WRAPPER_OPTIONS
 FOREIGN KEY (FOREIGN_DATA_WRAPPER_CATALOG, FOREIGN_DATA_WRAPPER_NAME)
 REFERENCES FOREIGN_DATA_WRAPPER_OPTIONS
)
```

### Description

- 1) The values of FOREIGN\_DATA\_WRAPPER\_CATALOG and FOREIGN\_DATA\_WRAPPER\_NAME are the catalog name and qualified identifier, respectively, of the foreign-data wrapper for which the option being described is specified.
- 2) The value of OPTION\_NAME identifies the option being described.
- 3) The value of OPTION\_VALUE is the value specified for the option being described. The value of OPTION\_VALUE is the null value if no value for the option being described was specified.

## 25.4 FOREIGN\_DATA\_WRAPPERS base table

### Function

The FOREIGN\_DATA\_WRAPPERS base table has one row for each foreign-data wrapper.

### Definition

```
CREATE TABLE FOREIGN_DATA_WRAPPERS (
 FOREIGN_DATA_WRAPPER_CATALOG INFORMATION_SCHEMA.SQL_IDENTIFIER,
 FOREIGN_DATA_WRAPPER_NAME INFORMATION_SCHEMA.SQL_IDENTIFIER,
 AUTHORIZATION_IDENTIFIER INFORMATION_SCHEMA.SQL_IDENTIFIER
 CONSTRAINT AUTHORIZATION_IDENTIFIER_NOT_NULL NOT NULL,
 LIBRARY_NAME INFORMATION_SCHEMA.SQL_CHARACTER_DATA,
 FOREIGN_DATA_WRAPPER_LANGUAGE INFORMATION_SCHEMA.SQL_CHARACTER_DATA,
 CONSTRAINT FOREIGN_DATA_WRAPPERS_PRIMARY_KEY
 PRIMARY KEY (FOREIGN_DATA_WRAPPER_CATALOG, FOREIGN_DATA_WRAPPER_NAME),
 CONSTRAINT FOREIGN_DATA_WRAPPERS_LANGUAGE_CHECK
 CHECK (FOREIGN_DATA_WRAPPER_LANGUAGE IN
 ('ADA', 'C', 'COBOL', 'FORTRAN',
 'MUMPS', 'PASCAL', 'PLI'))
)
```

### Description

- 1) The value of FOREIGN\_DATA\_WRAPPER\_CATALOG and FOREIGN\_DATA\_WRAPPER\_NAME are the catalog name and qualified identifier, respectively, of the foreign-data wrapper being described.
- 2) The value of AUTHORIZATION\_IDENTIFIER is the <authorization identifier> that owns the foreign-data wrapper being described.
- 3) The value of LIBRARY\_NAME is the name of the library that contains the foreign-data wrapper interface routines of the foreign-data wrapper being described.
- 4) The value of the FOREIGN\_DATA\_WRAPPER\_LANGUAGE is the language of the routines of the foreign-data wrapper being described.

## 25.5 FOREIGN\_SERVER\_OPTIONS base table

### Function

The FOREIGN\_SERVER\_OPTIONS base table has one row for each option specified for each foreign server.

### Definition

```
CREATE TABLE FOREIGN_SERVER_OPTIONS (
 FOREIGN_SERVER_CATALOG INFORMATION_SCHEMA.SQL_IDENTIFIER,
 FOREIGN_SERVER_NAME INFORMATION_SCHEMA.SQL_IDENTIFIER,
 OPTION_NAME INFORMATION_SCHEMA.SQL_IDENTIFIER,
 OPTION_VALUE INFORMATION_SCHEMA.SQL_CHARACTER_DATA,
 CONSTRAINT FOREIGN_SERVERS_PRIMARY_KEY
 PRIMARY KEY (FOREIGN_SERVER_CATALOG, FOREIGN_SERVER_NAME, OPTION_NAME),
 CONSTRAINT FOREIGN_SERVER_OPTIONS_FOREIGN_KEY_FOREIGN_SERVERS
 FOREIGN KEY (FOREIGN_SERVER_CATALOG, FOREIGN_SERVER_NAME)
 REFERENCES FOREIGN_SERVERS
)
```

### Description

- 1) The values of FOREIGN\_SERVER\_CATALOG and FOREIGN\_SERVER\_NAME are the catalog name and qualified identifier, respectively, of the foreign server for which the option being described is specified.
- 2) The value of OPTION\_NAME identifies the option being described.
- 3) The value of OPTION\_VALUE is the value specified for the option being described. The value of OPTION\_VALUE is the null value if no value for the option being described was specified.

## 25.6 FOREIGN\_SERVERS base table

### Function

The FOREIGN\_SERVERS base table has one row for each foreign server.

### Definition

```
CREATE TABLE FOREIGN_SERVERS (
 FOREIGN_SERVER_CATALOG INFORMATION_SCHEMA.SQL_IDENTIFIER,
 FOREIGN_SERVER_NAME INFORMATION_SCHEMA.SQL_IDENTIFIER,
 FOREIGN_DATA_WRAPPER_CATALOG INFORMATION_SCHEMA.SQL_IDENTIFIER
 CONSTRAINT FOREIGN_SERVER_FOREIGN_DATA_WRAPPER_CATALOG_NOT_NULL NOT NULL,
 FOREIGN_DATA_WRAPPER_NAME INFORMATION_SCHEMA.SQL_IDENTIFIER
 CONSTRAINT FOREIGN_SERVER_FOREIGN_DATA_WRAPPER_NAME_NOT_NULL NOT NULL,
 FOREIGN_SERVER_TYPE INFORMATION_SCHEMA.CHARACTER_DATA,
 FOREIGN_SERVER_VERSION INFORMATION_SCHEMA.CHARACTER_DATA,
 AUTHORIZATION_IDENTIFIER INFORMATION_SCHEMA.SQL_IDENTIFIER
 CONSTRAINT AUTHORIZATION_IDENTIFIER_NOT_NULL NOT NULL,
 CONSTRAINT FOREIGN_SERVERS_PRIMARY_KEY
 PRIMARY KEY (FOREIGN_SERVER_CATALOG, FOREIGN_SERVER_NAME),
 CONSTRAINT FOREIGN_SERVERS_FOREIGN_KEY_FOREIGN_DATA_WRAPPER_CATALOG
 FOREIGN KEY (FOREIGN_DATA_WRAPPER_CATALOG, FOREIGN_DATA_WRAPPER_NAME)
 REFERENCES FOREIGN_DATA_WRAPPER_CATALOG
)
```

### Description

- 1) The value of FOREIGN\_SERVER\_CATALOG and FOREIGN\_SERVER\_NAME are the catalog name and qualified identifier, respectively, of the foreign server being described.
- 2) The value of FOREIGN\_DATA\_WRAPPER\_CATALOG and FOREIGN\_DATA\_WRAPPER\_NAME are the catalog name and qualified identifier, respectively, of the foreign-data wrapper used when the foreign server being described is accessed.
- 3) If the value of FOREIGN\_SERVER\_TYPE is not the null value, then it identifies the type of the foreign server being described.
- 4) If the value of FOREIGN\_SERVER\_VERSION is not the null value, then it identifies the version of the type of the foreign server being described.
- 5) The value of AUTHORIZATION\_IDENTIFIER is the authorization identifier that owns the foreign server being described.

## 25.7 FOREIGN\_TABLE\_OPTIONS base table

### Function

The FOREIGN\_TABLE\_OPTIONS base table has one row for each option specified for each foreign table.

### Definition

```
CREATE TABLE FOREIGN_TABLE_OPTIONS (
 FOREIGN_TABLE_CATALOG INFORMATION_SCHEMA.SQL_IDENTIFIER,
 FOREIGN_TABLE_SCHEMA INFORMATION_SCHEMA.SQL_IDENTIFIER,
 FOREIGN_TABLE_NAME INFORMATION_SCHEMA.SQL_IDENTIFIER,
 OPTION_NAME INFORMATION_SCHEMA.SQL_IDENTIFIER,
 OPTION_VALUE INFORMATION_SCHEMA.SQL_CHARACTER_DATA,
 CONSTRAINT FOREIGN_TABLE_OPTIONS_PRIMARY_KEY
 PRIMARY KEY (FOREIGN_TABLE_CATALOG, FOREIGN_TABLE_SCHEMA,
 FOREIGN_TABLE_NAME, OPTION_NAME),
 CONSTRAINT FOREIGN_TABLE_OPTIONS_FOREIGN_KEY_FOREIGN_TABLES
 FOREIGN KEY (FOREIGN_TABLE_CATALOG, FOREIGN_TABLE_SCHEMA, FOREIGN_TABLE_NAME)
 REFERENCES FOREIGN_TABLES
)
```

### Description

- 1) The values of FOREIGN\_TABLE\_CATALOG, FOREIGN\_TABLE\_SCHEMA and FOREIGN\_TABLE\_NAME are the catalog name and qualified identifier, respectively, of the foreign table for which the option being described is specified.
- 2) The value of OPTION\_NAME identifies the option being described.
- 3) The value of OPTION\_VALUE is the value specified for the option being described. The value of OPTION\_VALUE is the null value if no value for the option being described was specified.

## 25.8 FOREIGN\_TABLES base table

### Function

The FOREIGN\_TABLES base table has one row for each foreign table.

### Definition

```
CREATE TABLE FOREIGN_TABLES (
 FOREIGN_TABLE_CATALOG INFORMATION_SCHEMA.SQL_IDENTIFIER,
 FOREIGN_TABLE_SCHEMA INFORMATION_SCHEMA.SQL_IDENTIFIER,
 FOREIGN_TABLE_NAME INFORMATION_SCHEMA.SQL_IDENTIFIER,
 FOREIGN_SERVER_CATALOG INFORMATION_SCHEMA.SQL_IDENTIFIER,
 FOREIGN_SERVER_NAME INFORMATION_SCHEMA.SQL_IDENTIFIER,
 CONSTRAINT FOREIGN_TABLES_PRIMARY_KEY
 PRIMARY KEY (FOREIGN_TABLE_CATALOG, FOREIGN_TABLE_SCHEMA,
 FOREIGN_TABLE_NAME),
 CONSTRAINT FOREIGN_TABLES_FOREIGN_KEY_FOREIGN_SERVERS
 FOREIGN KEY (FOREIGN_SERVER_CATALOG, FOREIGN_SERVER_NAME)
 REFERENCES FOREIGN_SERVERS,
 CONSTRAINT FOREIGN_TABLES_IN_TABLES_CHECK
 CHECK ((FOREIGN_TABLE_CATALOG, FOREIGN_TABLE_SCHEMA,
 FOREIGN_TABLE_NAME)
 IN
 (SELECT TABLE_CATALOG, TABLE_SCHEMA,
 TABLE_NAME
 FROM TABLES
 WHERE TABLE_TYPE = 'FOREIGN'))
)
```

### Description

- 1) The values of FOREIGN\_TABLE\_CATALOG, FOREIGN\_TABLE\_SCHEMA and FOREIGN\_TABLE\_NAME are the catalog name, unqualified schema name, and qualified identifier, respectively, of the foreign table being described.
- 2) The values of FOREIGN\_SERVER\_CATALOG and FOREIGN\_SERVER\_NAME are the catalog name and qualified identifier, respectively, of the foreign server that is the source of the foreign table being described.



## 25.9 ROUTINE\_MAPPING\_OPTIONS base table

### Function

The ROUTINE\_MAPPING\_OPTIONS base table has one row for each option specified for each routine mapping.

### Definition

```
CREATE TABLE ROUTINE_MAPPING_OPTIONS (
 ROUTINE_MAPPING_NAME INFORMATION_SCHEMA.SQL_IDENTIFIER,
 OPTION_NAME INFORMATION_SCHEMA.SQL_IDENTIFIER,
 OPTION_VALUE INFORMATION_SCHEMA.SQL_CHARACTER_DATA,
 CONSTRAINT ROUTINE_MAPPING_OPTIONS_PRIMARY_KEY
 PRIMARY KEY (ROUTINE_MAPPING_NAME, OPTION_NAME),
 CONSTRAINT ROUTINE_MAPPING_OPTIONS_FOREIGN_KEY_ROUTINE_MAPPINGS
 FOREIGN KEY (ROUTINE_MAPPING_NAME)
 REFERENCES ROUTINE_MAPPINGS
)
```

### Description

- 1) The value of ROUTINE\_MAPPING\_NAME is the identifier of the routine mapping for which the option being described is specified.
- 2) The value of OPTION\_NAME identifies the option being described.
- 3) The value of OPTION\_VALUE is the value specified for the option being described. The value of OPTION\_VALUE is the null value if no value for the option being described was specified.

## 25.10 ROUTINE\_MAPPINGS base table

### Function

The ROUTINE\_MAPPINGS base table has one row for each routine mapping.

### Definition

```
CREATE TABLE ROUTINE_MAPPINGS (
 ROUTINE_MAPPING_NAME INFORMATION_SCHEMA.SQL_IDENTIFIER,
 SPECIFIC_CATALOG INFORMATION_SCHEMA.SQL_IDENTIFIER,
 SPECIFIC_SCHEMA INFORMATION_SCHEMA.SQL_IDENTIFIER,
 SPECIFIC_NAME INFORMATION_SCHEMA.SQL_IDENTIFIER,
 FOREIGN_SERVER_CATALOG INFORMATION_SCHEMA.SQL_IDENTIFIER,
 FOREIGN_SERVER_NAME INFORMATION_SCHEMA.SQL_IDENTIFIER,
 CONSTRAINT ROUTINE_MAPPINGS_PRIMARY_KEY
 PRIMARY KEY (ROUTINE_MAPPING_NAME),
 CONSTRAINT ROUTINE_MAPPINGS_FOREIGN_KEY_FOREIGN_SERVERS
 FOREIGN KEY (FOREIGN_SERVER_CATALOG, FOREIGN_SERVER_NAME)
 REFERENCES FOREIGN_SERVERS,
 CONSTRAINT ROUTINE_MAPPINGS_FOREIGN_KEY_ROUTINES
 FOREIGN KEY (SPECIFIC_CATALOG, SPECIFIC_SCHEMA, SPECIFIC_NAME)
 REFERENCES ROUTINES,
 CONSTRAINT ROUTINE_MAPPINGS_UNIQUE_MAPPING_ROUTINE_SERVER
 UNIQUE (SPECIFIC_CATALOG, SPECIFIC_SCHEMA,
 SPECIFIC_NAME, FOREIGN_SERVER_CATALOG,
 FOREIGN_SERVER_NAME)
)
```

### Description

- 1) The value of ROUTINE\_MAPPING\_NAME identifies the routine mapping being described.
- 2) The values of SPECIFIC\_CATALOG, SPECIFIC\_SCHEMA, and SPECIFIC\_NAME, are the catalog name, unqualified schema name, and qualified identifier, respectively, of the specific routine name of the routine mapping being described.
- 3) The values of FOREIGN\_SERVER\_CATALOG and FOREIGN\_SERVER\_NAME are the catalog name and qualified identifier, respectively, of the foreign server of the routine mapping being described.

## 25.11 SQL\_SIZING base table

*This Subclause modifies Subclause 7.2, “SQL\_SIZING base table”, in ISO/IEC 9075-3.*

### Function

The SQL\_SIZING base table has one row for each sizing item defined by ISO/IEC 9075.

### Definition

*No additional Definition.*

### Description

*No additional Descriptions.*

### Table Population

Add the following item to the list of INSERT values

```
(20004, 'MAXIMUM DATALINK LENGTH',
 'Length in octets'),
```

## 25.12 TABLES base table

*This Subclause modifies Subclause 6.51, “TABLES base table”, in ISO/IEC 9075-11.*

### Function

The TABLES base table contains one row for each table, including views and foreign tables. It effectively contains a representation of the table descriptors.

### Definition

Augment the column constraint TABLE\_TYPE\_CHECK Add “, ' FOREIGN' ” to the <in value list> of valid TABLE\_TYPE values.

### Description

- 1) Augment Description 2)

|         |                                               |
|---------|-----------------------------------------------|
| FOREIGN | The table being described is a foreign table. |
|---------|-----------------------------------------------|

## 25.13 USAGE\_PRIVILEGES base table

*This Subclause modifies Subclause 6.60, “USAGE\_PRIVILEGES base table”, in ISO/IEC 9075-11.*

### Function

The USAGE\_PRIVILEGES table has one row for each usage privilege descriptor. It effectively contains a representation of the usage privilege descriptors.

### Definition

*No additional Definition.*

### Description

- 1) Replace Desc. 3) Case:
  - a) If the object to which the privileges apply is a foreign-data wrapper or a foreign server, then the values of OBJECT\_CATALOG and OBJECT\_NAME are the catalog name, and qualified identifier, respectively, of the object to which the privilege applies and OBJECT\_SCHEMA is the empty string.
  - b) Otherwise, the values of OBJECT\_CATALOG, OBJECT\_SCHEMA, and OBJECT\_NAME are the catalog name, unqualified schema name, and qualified identifier, respectively, of the object to which the privilege applies.

## 25.14 USER\_MAPPING\_OPTIONS base table

### Function

The USER\_MAPPING\_OPTIONS base table has one row for each option specified for each user mapping.

### Definition

```
CREATE TABLE USER_MAPPING_OPTIONS (
 AUTHORIZATION_IDENTIFIER INFORMATION_SCHEMA.SQL_IDENTIFIER,
 FOREIGN_SERVER_CATALOG INFORMATION_SCHEMA.SQL_IDENTIFIER,
 FOREIGN_SERVER_NAME INFORMATION_SCHEMA.SQL_IDENTIFIER,
 OPTION_NAME INFORMATION_SCHEMA.SQL_IDENTIFIER,
 OPTION_VALUE INFORMATION_SCHEMA.SQL_CHARACTER_DATA,
 CONSTRAINT USER_MAPPING_OPTIONS_PRIMARY_KEY
 PRIMARY KEY (AUTHORIZATION_IDENTIFIER, FOREIGN_SERVER_CATALOG,
 FOREIGN_SERVER_NAME, OPTION_NAME),
 CONSTRAINT USER_MAPPING_OPTIONS_FOREIGN_KEY_USER_MAPPINGS
 FOREIGN KEY (AUTHORIZATION_IDENTIFIER, FOREIGN_SERVER_CATALOG,
 FOREIGN_SERVER_NAME)
 REFERENCES USER_MAPPINGS
)
```

### Description

- 1) The values of AUTHORIZATION\_IDENTIFIER, FOREIGN\_SERVER\_CATALOG and FOREIGN\_SERVER\_NAME are the authorization identifier, the catalog name and qualified identifier, respectively, of the user mapping for which the option being described is specified.
- 2) The value of OPTION\_NAME identifies the option being described.
- 3) The value of OPTION\_VALUE is the value specified for the option being described. The value of OPTION\_VALUE is the null value if no value for the option being described was specified.

## 25.15 USER\_MAPPINGS base table

### Function

The USER\_MAPPINGS base table has one row for each user mapping.

### Definition

```
CREATE TABLE USER_MAPPINGS (
 AUTHORIZATION_IDENTIFIER INFORMATION_SCHEMA.SQL_IDENTIFIER,
 FOREIGN_SERVER_CATALOG INFORMATION_SCHEMA.SQL_IDENTIFIER,
 FOREIGN_SERVER_NAME INFORMATION_SCHEMA.SQL_IDENTIFIER,
 CONSTRAINT USER_MAPPINGS_PRIMARY_KEY
 PRIMARY KEY (AUTHORIZATION_IDENTIFIER, FOREIGN_SERVER_CATALOG,
 FOREIGN_SERVER_NAME),
 CONSTRAINT USER_MAPPINGS_FOREIGN_KEY_FOREIGN_SERVERS
 FOREIGN KEY (FOREIGN_SERVER_CATALOG, FOREIGN_SERVER_NAME)
 REFERENCES FOREIGN_SERVERS
)
```

### Description

- 1) The value of AUTHORIZATION\_IDENTIFIER identifies the authorization identifier whose user mapping for the foreign server identified by FOREIGN\_SERVER\_CATALOG and FOREIGN\_SERVER\_NAME is being described.
- 2) The values of FOREIGN\_SERVER\_CATALOG and FOREIGN\_SERVER\_NAME are the catalog name and qualified identifier, respectively, of the foreign server for which the user mapping is being described.

## 26 Status codes

This Clause modifies Clause 23, “Status codes”, in ISO/IEC 9075-2.

### 26.1 SQLSTATE

This Subclause modifies Subclause 23.1, “SQLSTATE”, in ISO/IEC 9075-2.

Insert this paragraph Some of the conditions that can occur during the execution of foreign-data wrapper interface routines are SQL/MED-specific. The corresponding status codes are listed in Table 37, “SQLSTATE class and subclass values”. Diagnostic information relating to FDW-specific conditions can arise only in a foreign-data wrapper diagnostics area.

Table 37, “SQLSTATE class and subclass values”, modifies Table 32, “SQLSTATE class and subclass values”, in ISO/IEC 9075-2.

**Table 37 — SQLSTATE class and subclass values**

| Category | Condition                                   | Class | Subcondition                                        | Subclass |
|----------|---------------------------------------------|-------|-----------------------------------------------------|----------|
|          | <i>All alternatives from ISO/IEC 9075-2</i> |       |                                                     |          |
| X        | <i>CLI-specific condition</i>               | HY    | <i>invalid datalink value</i>                       | 093      |
| X        | <i>data exception</i>                       | 22    | <i>(no subclass)</i>                                | 000      |
|          |                                             |       | <i>invalid data specified for datalink</i>          | 017      |
|          |                                             |       | <i>null argument passed to datalink constructor</i> | 01A      |
|          |                                             |       | <i>datalink value exceeds maximum length</i>        | 01D      |
| X        | <i>datalink exception</i>                   | HW    | <i>(no subclass)</i>                                | 000      |
|          |                                             |       | <i>external file not linked</i>                     | 001      |
|          |                                             |       | <i>external file already linked</i>                 | 002      |
|          |                                             |       | <i>invalid write token</i>                          | 004      |
|          |                                             |       | <i>invalid datalink construction</i>                | 005      |



26.1 SQLSTATE

| Category | Condition                     | Class | Subcondition                                  | Subclass |
|----------|-------------------------------|-------|-----------------------------------------------|----------|
|          |                               |       | <i>invalid write permission for update</i>    | 006      |
|          |                               |       | <i>referenced file does not exist</i>         | 003      |
|          |                               |       | <i>referenced file not valid</i>              | 007      |
| X        | <i>FDW-specific condition</i> | HV    | (no subclass)                                 | 000      |
|          |                               |       | <i>column name not found</i>                  | 005      |
|          |                               |       | <i>dynamic parameter value needed</i>         | 002      |
|          |                               |       | <i>function sequence error</i>                | 010      |
|          |                               |       | <i>inconsistent descriptor information</i>    | 021      |
|          |                               |       | <i>invalid attribute value</i>                | 024      |
|          |                               |       | <i>invalid column name</i>                    | 007      |
|          |                               |       | <i>invalid column number</i>                  | 008      |
|          |                               |       | <i>invalid data type</i>                      | 004      |
|          |                               |       | <i>invalid data type descriptors</i>          | 006      |
|          |                               |       | <i>invalid descriptor field identifier</i>    | 091      |
|          |                               |       | <i>invalid handle</i>                         | 00B      |
|          |                               |       | <i>invalid option index</i>                   | 00C      |
|          |                               |       | <i>invalid option name</i>                    | 00D      |
|          |                               |       | <i>invalid string length or buffer length</i> | 090      |
|          |                               |       | <i>invalid string format</i>                  | 00A      |
|          |                               |       | <i>invalid use of null pointer</i>            | 009      |
|          |                               |       | <i>limit on number of handles exceeded</i>    | 014      |
|          |                               |       | <i>memory allocation error</i>                | 001      |
|          |                               |       | <i>no schemas</i>                             | 00P      |
|          |                               |       | <i>option name not found</i>                  | 00J      |

| Category | Condition                                   | Class | Subcondition                          | Subclass |
|----------|---------------------------------------------|-------|---------------------------------------|----------|
|          |                                             |       | <i>reply handle</i>                   | 00K      |
|          |                                             |       | <i>schema not found</i>               | 00Q      |
|          |                                             |       | <i>table not found</i>                | 00R      |
|          |                                             |       | <i>unable to create execution</i>     | 00L      |
|          |                                             |       | <i>unable to create reply</i>         | 00M      |
|          |                                             |       | <i>unable to establish connection</i> | 00N      |
| X        | <i>invalid foreign server specification</i> | 0X    | <i>(no subclass)</i>                  | 000      |
| X        | <i>pass-through specific condition</i>      | 0Y    | <i>(no subclass)</i>                  | 000      |
|          |                                             |       | <i>invalid cursor option</i>          | 001      |
|          |                                             |       | <i>invalid cursor allocation</i>      | 002      |

*(Blank page)*

## 27 Conformance

### 27.1 Claims of conformance to SQL/MED

In addition to the requirements of ISO/IEC 9075-1, Clause 8, “Conformance”, a claim of conformance to this part of ISO/IEC 9075 shall:

- 1) Claim conformance to at least one of:
  - Feature M002, “Datalinks via SQL/CLI”
  - Feature M003, “Datalinks via Embedded SQL”
  - Feature M004, “Foreign data support”
  - Feature M010, “Foreign-data wrapper support”
  - Feature M030, “SQL-server foreign data support”

### 27.2 Additional conformance requirements for SQL/MED

Each claim of conformance to Feature M002, “Datalinks via SQL/CLI”, shall also claim conformance to at least one of:

- Feature C001, “CLI routine invocation in Ada”
- Feature C002, “CLI routine invocation in C”
- Feature C003, “CLI routine invocation in COBOL”
- Feature C004, “CLI routine invocation in Fortran”
- Feature C005, “CLI routine invocation in MUMPS”
- Feature C006, “CLI routine invocation in Pascal”
- Feature C007, “CLI routine invocation in PL/I”

Each claim of conformance to Feature M003, “Datalinks via Embedded SQL”, shall also claim conformance to at least one of:

- Feature M011, “Datalinks via Ada”
- Feature M012, “Datalinks via C”
- Feature M013, “Datalinks via COBOL”
- Feature M014, “Datalinks via Fortran”

**27.2 Additional conformance requirements for SQL/MED**

- Feature M015, “Datalinks via M”
- Feature M016, “Datalinks via Pascal”
- Feature M017, “Datalinks via PL/I”

Each claim of conformance to Feature M010, “Foreign-data wrapper support”, shall also claim conformance to at least one of:

- Feature M018, “Foreign-data wrapper interface routines in Ada”
- Feature M019, “Foreign-data wrapper interface routines in C”
- Feature M020, “Foreign-data wrapper interface routines in COBOL”
- Feature M021, “Foreign-data wrapper interface routines in Fortran”
- Feature M022, “Foreign-data wrapper interface routines in MUMPS”
- Feature M023, “Foreign-data wrapper interface routines in Pascal”
- Feature M024, “Foreign-data wrapper interface routines in PL/I”

Each claim of conformance to Feature M030, “SQL-server foreign data support”, shall also claim conformance to at least one of:

- Feature M018, “Foreign-data wrapper interface routines in Ada”
- Feature M019, “Foreign-data wrapper interface routines in C”
- Feature M020, “Foreign-data wrapper interface routines in COBOL”
- Feature M021, “Foreign-data wrapper interface routines in Fortran”
- Feature M022, “Foreign-data wrapper interface routines in MUMPS”
- Feature M023, “Foreign-data wrapper interface routines in Pascal”
- Feature M024, “Foreign-data wrapper interface routines in PL/I”

Each claim of conformance to Feature M031, “Foreign-data wrapper general routines”, shall also claim conformance to at least one of:

- Feature M010, “Foreign-data wrapper support”
- Feature M030, “SQL-server foreign data support”

A claim of support for Feature M030, “SQL-server foreign data support”, shall only be made by an implementation of an SQL-server or a foreign-data wrapper.

An SQL-server shall not claim support for Feature M004, “Foreign data support”, unless it also claims support for Feature M030, “SQL-server foreign data support”.

A claim of support for Feature M010, “Foreign-data wrapper support” shall only be made by an implementation of a foreign-data wrapper or an SQL-server.

Table 38 — Implied feature relationships of SQL/MED

| Feature ID | Feature Name                       | Implied Feature ID | Implied Feature Name                  |
|------------|------------------------------------|--------------------|---------------------------------------|
| M002       | Datalinks via SQL/CLI              | C001               | SQL/CLI                               |
| M002       | Datalinks via SQL/CLI              | M001               | Datalinks                             |
| M003       | Datalinks via Embedded SQL         | M001               | Datalinks                             |
| M005       | Foreign schema support             | M004               | Foreign data support                  |
| M006       | GetSQLString routine               | M030               | SQL-server foreign data support       |
| M007       | TransmitRequest                    | M010               | Foreign-data wrapper support          |
| M009       | GetOpts and GetStatistics routines | M010               | Foreign-data wrapper support          |
| M010       | Foreign-data wrapper support       | M031               | Foreign-data wrapper general routines |
| M011       | Datalinks via Ada                  | M003               | Datalinks via Embedded SQL            |
| M012       | Datalinks via C                    | M003               | Datalinks via Embedded SQL            |
| M013       | Datalinks via COBOL                | M003               | Datalinks via Embedded SQL            |
| M014       | Datalinks via Fortran              | M003               | Datalinks via Embedded SQL            |
| M015       | Datalinks via M                    | M003               | Datalinks via Embedded SQL            |
| M016       | Datalinks via Pascal               | M003               | Datalinks via Embedded SQL            |
| M017       | Datalinks via PL/I                 | M003               | Datalinks via Embedded SQL            |
| M030       | SQL-server foreign data support    | M031               | Foreign-data wrapper general routines |

*(Blank page)*

## Annex A (informative)

### SQL Conformance Summary

*This Annex modifies Annex A, “SQL Conformance Summary”, in ISO/IEC 9075-2.*

The contents of this Annex summarizes all Conformance Rules, ordered by Feature ID and by Subclause.

- 1) Specifications for Feature F391, “Long identifiers”:
  - a) Subclause 24.4, “FOREIGN\_DATA\_WRAPPER\_OPTIONS view”:
    - i) Without Feature F391, “Long identifiers”, conforming SQL language shall not reference INFORMATION\_SCHEMA . FOREIGN\_DATA\_WRAPPER\_OPTIONS.
  - b) Subclause 24.5, “FOREIGN\_DATA\_WRAPPERS view”:
    - i) Without Feature F391, “Long identifiers”, conforming SQL language shall not reference INFORMATION\_SCHEMA . FOREIGN\_DATA\_WRAPPERS.
  - c) Subclause 24.6, “FOREIGN\_SERVER\_OPTIONS view”:
    - i) Without Feature F391, “Long identifiers”, conforming SQL language shall not reference INFORMATION\_SCHEMA . FOREIGN\_SERVER\_OPTIONS.
  - d) Subclause 24.7, “FOREIGN\_SERVERS view”:
    - i) Without Feature F391, “Long identifiers”, conforming SQL language shall not reference INFORMATION\_SCHEMA . FOREIGN\_SERVERS.
  - e) Subclause 24.8, “FOREIGN\_TABLE\_OPTIONS view”:
    - i) Without Feature F391, “Long identifiers”, conforming SQL language shall not reference INFORMATION\_SCHEMA . FOREIGN\_TABLE\_OPTIONS.
  - f) Subclause 24.9, “FOREIGN\_TABLES view”:
    - i) Without Feature F391, “Long identifiers”, conforming SQL language shall not reference INFORMATION\_SCHEMA . FOREIGN\_TABLES.
  - g) Subclause 24.10, “ROUTINE\_MAPPING\_OPTIONS view”:
    - i) Without Feature F391, “Long identifiers”, conforming SQL language shall not reference INFORMATION\_SCHEMA . ROUTINE\_MAPPING\_OPTIONS.
  - h) Subclause 24.11, “ROUTINE\_MAPPINGS view”:
    - i) Without Feature F391, “Long identifiers”, conforming SQL language shall not reference INFORMATION\_SCHEMA . ROUTINE\_MAPPINGS.



- i) Subclause 24.12, “USER\_MAPPING\_OPTIONS view”:
    - i) Without Feature F391, “Long identifiers”, conforming SQL language shall not reference INFORMATION\_SCHEMA . USER\_MAPPING\_OPTIONS.
  - j) Subclause 24.13, “USER\_MAPPINGS view”:
    - i) Without Feature F391, “Long identifiers”, conforming SQL language shall not reference INFORMATION\_SCHEMA . USER\_MAPPINGS.
- 2) Specifications for Feature M001, “Datalinks”:
- a) Subclause 6.1, “<data type>”:
    - i) Without Feature M001, “Datalinks”, conforming SQL language shall not contain a <datalink type>.
  - b) Subclause 6.5, “<datalink value expression>”:
    - i) Without Feature M001, “Datalinks”, conforming SQL language shall not contain a <datalink value expression>.
  - c) Subclause 6.6, “<datalink value function>”:
    - i) Without Feature M001, “Datalinks”, conforming SQL language shall not contain a <datalink value function>.
  - d) Subclause 24.1, “ATTRIBUTES view”:
    - i) Insert this CR Without Feature M001, “Datalinks”, conforming SQL language shall not reference INFORMATION\_SCHEMA . ATTRIBUTES . DATALINK\_INTEGRITY.
    - ii) Insert this CR Without Feature M001, “Datalinks”, conforming SQL language shall not reference INFORMATION\_SCHEMA . ATTRIBUTES . DATALINK\_LINK\_CONTROL.
    - iii) Insert this CR Without Feature M001, “Datalinks”, conforming SQL language shall not reference INFORMATION\_SCHEMA . ATTRIBUTES . DATALINK\_READ\_PERMISSION.
    - iv) Insert this CR Without Feature M001, “Datalinks”, conforming SQL language shall not reference INFORMATION\_SCHEMA . ATTRIBUTES . DATALINK\_RECOVERY.
    - v) Insert this CR Without Feature M001, “Datalinks”, conforming SQL language shall not reference INFORMATION\_SCHEMA . ATTRIBUTES . DATALINK\_UNLINK.
    - vi) Insert this CR Without Feature M001, “Datalinks”, conforming SQL language shall not reference INFORMATION\_SCHEMA . ATTRIBUTES . DATALINK\_WRITE\_PERMISSION.
  - e) Subclause 24.3, “COLUMNS view”:
    - i) Insert this CR Without Feature M001, “Datalinks”, conforming SQL language shall not reference INFORMATION\_SCHEMA . COLUMNS . DATALINK\_INTEGRITY.
    - ii) Insert this CR Without Feature M001, “Datalinks”, conforming SQL language shall not reference INFORMATION\_SCHEMA . COLUMNS . DATALINK\_LINK\_CONTROL.
    - iii) Insert this CR Without Feature M001, “Datalinks”, conforming SQL language shall not reference INFORMATION\_SCHEMA . COLUMNS . DATALINK\_READ\_PERMISSION.

- iv) Insert this CR Without Feature M001, “Datalinks”, conforming SQL language shall not reference INFORMATION\_SCHEMA . COLUMNS . DATALINK\_RECOVERY.
  - v) Insert this CR Without Feature M001, “Datalinks”, conforming SQL language shall not reference INFORMATION\_SCHEMA . COLUMNS . DATALINK\_UNLINK.
  - vi) Insert this CR Without Feature M001, “Datalinks”, conforming SQL language shall not reference INFORMATION\_SCHEMA . COLUMNS . DATALINK\_WRITE\_PERMISSION.
- f) Subclause 24.14, “Short name views”:
- i) Without Feature M001, “Datalinks”, conforming SQL language shall not reference INFORMATION\_SCHEMA . ATTRIBUTES\_S . DATALINK\_CONTROL.
  - ii) Without Feature M001, “Datalinks”, conforming SQL language shall not reference INFORMATION\_SCHEMA . ATTRIBUTES\_S . DL\_INTEGRITY.
  - iii) Without Feature M001, “Datalinks”, conforming SQL language shall not reference INFORMATION\_SCHEMA . ATTRIBUTES\_S . DL\_R\_PERMISSION.
  - iv) Without Feature M001, “Datalinks”, conforming SQL language shall not reference INFORMATION\_SCHEMA . ATTRIBUTES\_S . DL\_RECOVERY.
  - v) Without Feature M001, “Datalinks”, conforming SQL language shall not reference INFORMATION\_SCHEMA . ATTRIBUTES\_S . DL\_W\_PERMISSION.
  - vi) Without Feature M001, “Datalinks”, conforming SQL language shall not reference INFORMATION\_SCHEMA . ATTRIBUTES\_S . DATALINK\_UNLINK.
  - vii) Without Feature M001, “Datalinks”, conforming SQL language shall not reference INFORMATION\_SCHEMA . COLUMNS\_S . DATALINK\_CONTROL.
  - viii) Without Feature M001, “Datalinks”, conforming SQL language shall not reference INFORMATION\_SCHEMA . COLUMNS\_S . DL\_INTEGRITY.
  - ix) Without Feature M001, “Datalinks”, conforming SQL language shall not reference INFORMATION\_SCHEMA . COLUMNS\_S . DL\_R\_PERMISSION.
  - x) Without Feature M001, “Datalinks”, conforming SQL language shall not reference INFORMATION\_SCHEMA . COLUMNS\_S . DL\_RECOVERY.
  - xi) Without Feature M001, “Datalinks”, conforming SQL language shall not reference INFORMATION\_SCHEMA . COLUMNS\_S . DL\_W\_PERMISSION.
  - xii) Without Feature M001, “Datalinks”, conforming SQL language shall not reference INFORMATION\_SCHEMA . COLUMNS\_S . DATALINK\_UNLINK.
- 3) Specifications for Feature M002, “Datalinks via SQL/CLI”:
- a) Subclause 20.1, “BuildDataLink”:
    - i) Without Feature M002, “Datalinks via SQL/CLI”, conforming SQL language shall not contain BuildDataLink( ).  - b) Subclause 20.2, “GetDataLinkAttr”:
    - i) Without Feature M002, “Datalinks via SQL/CLI”, conforming SQL language shall not contain GetDataLinkAttr( ).

- c) Subclause 20.3, “GetInfo”:
  - i) Without Feature M002, “Datalinks via SQL/CLI”, in conforming SQL language, the value of InfoType shall not indicate MAXIMUM DATALINK LENGTH.
- 4) Specifications for Feature M003, “Datalinks via Embedded SQL”:
  - a) Subclause 18.1, “<embedded SQL Ada program>”:
    - i) Without Feature M003, “Datalinks via Embedded SQL”, conforming SQL language shall not contain an <Ada DATALINK variable>.
  - b) Subclause 18.2, “<embedded SQL C program>”:
    - i) Without Feature M003, “Datalinks via Embedded SQL”, conforming SQL language shall not contain a <C DATALINK variable>.
  - c) Subclause 18.3, “<embedded SQL COBOL program>”:
    - i) Without Feature M003, “Datalinks via Embedded SQL”, conforming SQL language shall not contain a <COBOL DATALINK variable>.
  - d) Subclause 18.4, “<embedded SQL Fortran program>”:
    - i) Without Feature M003, “Datalinks via Embedded SQL”, conforming SQL language shall not contain a <Fortran DATALINK variable>.
  - e) Subclause 18.5, “<embedded SQL MUMPS program>”:
    - i) Without Feature M003, “Datalinks via Embedded SQL”, conforming SQL language shall not contain a <MUMPS DATALINK variable>.
  - f) Subclause 18.6, “<embedded SQL Pascal program>”:
    - i) Without Feature M003, “Datalinks via Embedded SQL”, conforming SQL language shall not contain a <Pascal DATALINK variable>.
  - g) Subclause 18.7, “<embedded SQL PL/I program>”:
    - i) Without Feature M003, “Datalinks via Embedded SQL”, conforming SQL language shall not contain a <PL/I DATALINK variable>.
- 5) Specifications for Feature M004, “Foreign data support”:
  - a) Subclause 11.14, “<foreign table definition>”:
    - i) Without Feature M004, “Foreign data support”, conforming SQL language shall not contain a <foreign table definition>.
  - b) Subclause 11.15, “<alter foreign table statement>”:
    - i) Without Feature M004, “Foreign data support”, conforming SQL language shall not contain an <alter foreign table statement>.
  - c) Subclause 11.19, “<drop foreign table statement>”:
    - i) Without Feature M004, “Foreign data support”, conforming SQL language shall not contain a <drop foreign table statement>.

- d) Subclause 12.1, “<foreign server definition>”:
  - i) Without Feature M004, “Foreign data support”, conforming SQL language shall not contain a <foreign server definition>.
- e) Subclause 12.2, “<alter foreign server statement>”:
  - i) Without Feature M004, “Foreign data support”, conforming SQL language shall not contain an <alter foreign server statement>.
- f) Subclause 12.3, “<drop foreign server statement>”:
  - i) Without Feature M004, “Foreign data support”, conforming SQL language shall not contain a <drop foreign server statement>.
- g) Subclause 12.4, “<foreign-data wrapper definition>”:
  - i) Without Feature M004, “Foreign data support”, conforming SQL language shall not contain a <foreign-data wrapper definition>.
- h) Subclause 12.5, “<alter foreign-data wrapper statement>”:
  - i) Without Feature M004, “Foreign data support”, conforming SQL language shall not contain an <alter foreign-data wrapper statement>.
- i) Subclause 12.6, “<drop foreign-data wrapper statement>”:
  - i) Without Feature M004, “Foreign data support”, conforming SQL language shall not contain a <drop foreign-data wrapper statement>.
- j) Subclause 12.7, “<import foreign schema statement>”:
  - i) Without Feature M004, “Foreign data support”, conforming SQL language shall not contain an <import foreign schema statement>.
- k) Subclause 12.8, “<routine mapping definition>”:
  - i) Without Feature M004, “Foreign data support”, conforming SQL language shall not contain a <routine mapping definition>.
- l) Subclause 12.9, “<alter routine mapping statement>”:
  - i) Without Feature M004, “Foreign data support”, conforming SQL language shall not contain an <alter routine mapping statement>.
- m) Subclause 12.10, “<drop routine mapping statement>”:
  - i) Without Feature M004, “Foreign data support”, conforming SQL language shall not contain a <drop routine mapping statement>.
- n) Subclause 13.3, “<user mapping definition>”:
  - i) Without Feature M004, “Foreign data support”, conforming SQL language shall not contain a <user mapping definition>.
- o) Subclause 13.4, “<alter user mapping statement>”:
  - i) Without Feature M004, “Foreign data support”, conforming SQL language shall not contain an <alter user mapping statement>.

- p) Subclause 13.5, “<drop user mapping statement>”:
  - i) Without Feature M004, “Foreign data support”, conforming SQL language shall not contain a <drop user mapping statement>.
- q) Subclause 16.1, “<set passthrough statement>”:
  - i) Without Feature M004, “Foreign data support”, conforming SQL language shall not contain a <set passthrough statement>.
- r) Subclause 24.2, “COLUMN\_OPTIONS view”:
  - i) Without Feature M004, “Foreign data support”, conforming SQL language shall not reference INFORMATION\_SCHEMA . COLUMN\_OPTIONS.
- s) Subclause 24.4, “FOREIGN\_DATA\_WRAPPER\_OPTIONS view”:
  - i) Without Feature M004, “Foreign data support”, conforming SQL language shall not reference INFORMATION\_SCHEMA . FOREIGN\_DATA\_WRAPPER\_OPTIONS.
- t) Subclause 24.5, “FOREIGN\_DATA\_WRAPPERS view”:
  - i) Without Feature M004, “Foreign data support”, conforming SQL language shall not reference INFORMATION\_SCHEMA . FOREIGN\_DATA\_WRAPPERS.
- u) Subclause 24.6, “FOREIGN\_SERVER\_OPTIONS view”:
  - i) Without Feature M004, “Foreign data support”, conforming SQL language shall not reference INFORMATION\_SCHEMA . FOREIGN\_SERVER\_OPTIONS.
- v) Subclause 24.7, “FOREIGN\_SERVERS view”:
  - i) Without Feature M004, “Foreign data support”, conforming SQL language shall not reference INFORMATION\_SCHEMA . FOREIGN\_SERVERS.
- w) Subclause 24.8, “FOREIGN\_TABLE\_OPTIONS view”:
  - i) Without Feature M004, “Foreign data support”, conforming SQL language shall not reference INFORMATION\_SCHEMA . FOREIGN\_TABLE\_OPTIONS.
- x) Subclause 24.9, “FOREIGN\_TABLES view”:
  - i) Without Feature M004, “Foreign data support”, conforming SQL language shall not reference INFORMATION\_SCHEMA . FOREIGN\_TABLES.
- y) Subclause 24.10, “ROUTINE\_MAPPING\_OPTIONS view”:
  - i) Without Feature M004, “Foreign data support”, conforming SQL language shall not reference INFORMATION\_SCHEMA . ROUTINE\_MAPPING\_OPTIONS.
- z) Subclause 24.11, “ROUTINE\_MAPPINGS view”:
  - i) Without Feature M004, “Foreign data support”, conforming SQL language shall not reference INFORMATION\_SCHEMA . ROUTINE\_MAPPINGS.
- aa) Subclause 24.12, “USER\_MAPPING\_OPTIONS view”:
  - i) Without Feature M004, “Foreign data support”, conforming SQL language shall not reference INFORMATION\_SCHEMA . USER\_MAPPING\_OPTIONS.

## ab) Subclause 24.13, “USER\_MAPPINGS view”:

- i) Without Feature M004, “Foreign data support”, conforming SQL language shall not reference INFORMATION\_SCHEMA . USER\_MAPPINGS.

## ac) Subclause 24.14, “Short name views”:

- i) Without Feature M004, “Foreign data support”, conforming SQL language shall not reference INFORMATION\_SCHEMA . ATTRIBUTES\_S.
- ii) Without Feature M004, “Foreign data support”, conforming SQL language shall not reference INFORMATION\_SCHEMA . COLUMNS\_S.
- iii) Without Feature M004, “Foreign data support”, conforming SQL language shall not reference INFORMATION\_SCHEMA . FDW\_OPTIONS\_S.
- iv) Without Feature M004, “Foreign data support”, conforming SQL language shall not reference INFORMATION\_SCHEMA . FD\_WRAPPERS\_S.
- v) Without Feature M004, “Foreign data support”, conforming SQL language shall not reference INFORMATION\_SCHEMA . FS\_OPTIONS\_S.
- vi) Without Feature M004, “Foreign data support”, conforming SQL language shall not reference INFORMATION\_SCHEMA . FT\_OPTIONS\_S.
- vii) Without Feature M004, “Foreign data support”, conforming SQL language shall not reference INFORMATION\_SCHEMA . FOREIGN\_SERVERS\_S.
- viii) Without Feature M004, “Foreign data support”, conforming SQL language shall not reference INFORMATION\_SCHEMA . FOREIGN\_TABLES\_S.
- ix) Without Feature M004, “Foreign data support”, conforming SQL language shall not reference INFORMATION\_SCHEMA . ROUT\_MAP\_OPTIONS\_S.
- x) Without Feature M004, “Foreign data support”, conforming SQL language shall not reference INFORMATION\_SCHEMA . ROUTINE\_MAPPINGS\_S.
- xi) Without Feature M004, “Foreign data support”, conforming SQL language shall not reference INFORMATION\_SCHEMA . USER\_MAP\_OPTIONS\_S.
- xii) Without Feature M004, “Foreign data support”, conforming SQL language shall not reference INFORMATION\_SCHEMA . USER\_MAPPINGS\_S.

## 6) Specifications for Feature M005, “Foreign schema support”:

## a) Subclause 12.7, “&lt;import foreign schema statement&gt;”:

- i) Without Feature M005, “Foreign schema support”, conforming SQL language shall not specify <import foreign schema statement>.

## 7) Specifications for Feature M006, “GetSQLString routine”:

## a) Subclause 22.4.29, “GetSQLString”:

- i) Without Feature M006, “GetSQLString routine”, a conforming foreign-data wrapper shall not contain an invocation of a <foreign-data wrapper interface routine> that contains a <foreign-data wrapper interface routine name> that contains GetSQLString.

- 8) Specifications for Feature M007, “TransmitRequest”:
  - a) Subclause 22.3.35, “TransmitRequest”:
    - i) Without Feature M007, “TransmitRequest”, a conforming SQL-server shall not contain an invocation of a <foreign-data wrapper interface routine> that contains a <foreign-data wrapper interface routine name> that contains TransmitRequest.
- 9) Specifications for Feature M009, “GetOpts and GetStatistics routines”:
  - a) Subclause 22.3.16, “GetOpts”:
    - i) Without Feature M009, “GetOpts and GetStatistics routines”, a conforming SQL-server shall not contain an invocation of a <foreign-data wrapper interface routine> that contains a <foreign-data wrapper interface routine name> that contains GetOpts.
  - b) Subclause 22.3.28, “GetStatistics”:
    - i) Without Feature M009, “GetOpts and GetStatistics routines”, a conforming SQL-server shall not contain an invocation of a <foreign-data wrapper interface routine> that contains a <foreign-data wrapper interface routine name> that contains GetStatistics.
- 10) Specifications for Feature M010, “Foreign-data wrapper support”:
  - a) Subclause 22.3.1, “AdvanceInitRequest”:
    - i) Without Feature M010, “Foreign-data wrapper support”, a conforming SQL-server shall not contain an invocation of a <foreign-data wrapper interface routine> that contains a <foreign-data wrapper interface routine name> that contains AdvanceInitRequest.
  - b) Subclause 22.3.2, “AllocQueryContext”:
    - i) Without Feature M010, “Foreign-data wrapper support”, a conforming SQL-server shall not contain an invocation of a <foreign-data wrapper interface routine> that contains a <foreign-data wrapper interface routine name> that contains AllocQueryContext.
  - c) Subclause 22.3.3, “AllocWrapperEnv”:
    - i) Without Feature M010, “Foreign-data wrapper support”, a conforming SQL-server shall not contain an invocation of a <foreign-data wrapper interface routine> that contains a <foreign-data wrapper interface routine name> that contains AllocWrapperEnv.
  - d) Subclause 22.3.4, “Close”:
    - i) Without Feature M010, “Foreign-data wrapper support”, a conforming SQL-server shall not contain an invocation of a <foreign-data wrapper interface routine> that contains a <foreign-data wrapper interface routine name> that contains Close.
  - e) Subclause 22.3.5, “ConnectServer”:
    - i) Without Feature M010, “Foreign-data wrapper support”, a conforming SQL-server shall not contain an invocation of a <foreign-data wrapper interface routine> that contains a <foreign-data wrapper interface routine name> that contains ConnectServer.
  - f) Subclause 22.3.6, “FreeExecutionHandle”:

- i) Without Feature M010, “Foreign-data wrapper support”, a conforming SQL-server shall not contain an invocation of a <foreign-data wrapper interface routine> that contains a <foreign-data wrapper interface routine name> that contains FreeExecutionHandle.
- g) Subclause 22.3.7, “FreeFSCConnection”:
  - i) Without Feature M010, “Foreign-data wrapper support”, a conforming SQL-server shall not contain an invocation of a <foreign-data wrapper interface routine> that contains a <foreign-data wrapper interface routine name> that contains FreeFSCConnection.
- h) Subclause 22.3.8, “FreeQueryContext”:
  - i) Without Feature M010, “Foreign-data wrapper support”, a conforming SQL-server shall not contain an invocation of a <foreign-data wrapper interface routine> that contains a <foreign-data wrapper interface routine name> that contains FreeQueryContext.
- i) Subclause 22.3.9, “FreeReplyHandle”:
  - i) Without Feature M010, “Foreign-data wrapper support”, a conforming SQL-server shall not contain an invocation of a <foreign-data wrapper interface routine> that contains a <foreign-data wrapper interface routine name> that contains FreeReplyHandle.
- j) Subclause 22.3.10, “FreeWrapperEnv”:
  - i) Without Feature M010, “Foreign-data wrapper support”, a conforming SQL-server shall not contain an invocation of a <foreign-data wrapper interface routine> that contains a <foreign-data wrapper interface routine name> that contains FreeWrapperEnv.
- k) Subclause 22.3.11, “GetNextReply”:
  - i) Without Feature M010, “Foreign-data wrapper support”, a conforming SQL-server shall not contain an invocation of a <foreign-data wrapper interface routine> that contains a <foreign-data wrapper interface routine name> that contains GetNextReply.
- l) Subclause 22.3.12, “GetNumReplyBoolVE”:
  - i) Without Feature M010, “Foreign-data wrapper support”, a conforming SQL-server shall not contain an invocation of a <foreign-data wrapper interface routine> that contains a <foreign-data wrapper interface routine name> that contains GetNumReplyBoolVE.
- m) Subclause 22.3.13, “GetNumReplyOrderBy”:
  - i) Without Feature M010, “Foreign-data wrapper support”, a conforming SQL-server shall not contain an invocation of a <foreign-data wrapper interface routine> that contains a <foreign-data wrapper interface routine name> that contains GetNumReplyOrderBy.
- n) Subclause 22.3.14, “GetNumReplySelectElems”:
  - i) Without Feature M010, “Foreign-data wrapper support”, a conforming SQL-server shall not contain an invocation of a <foreign-data wrapper interface routine> that contains a <foreign-data wrapper interface routine name> that contains GetNumReplySelectElems.
- o) Subclause 22.3.15, “GetNumReplyTableRefs”:
  - i) Without Feature M010, “Foreign-data wrapper support”, a conforming SQL-server shall not contain an invocation of a <foreign-data wrapper interface routine> that contains a <foreign-data wrapper interface routine name> that contains GetNumReplyTableRefs.



- p) Subclause 22.3.17, “GetReplyBoolVE”:
  - i) Without Feature M010, “Foreign-data wrapper support”, a conforming SQL-server shall not contain an invocation of a <foreign-data wrapper interface routine> that contains a <foreign-data wrapper interface routine name> that contains GetReplyBoolVE.
- q) Subclause 22.3.18, “GetReplyCardinality”:
  - i) Without Feature M010, “Foreign-data wrapper support”, a conforming SQL-server shall not contain an invocation of a <foreign-data wrapper interface routine> that contains a <foreign-data wrapper interface routine name> that contains GetReplyCardinality.
- r) Subclause 22.3.19, “GetReplyDistinct”:
  - i) Without Feature M010, “Foreign-data wrapper support”, a conforming SQL-server shall not contain an invocation of a <foreign-data wrapper interface routine> that contains a <foreign-data wrapper interface routine name> that contains GetReplyDistinct.
- s) Subclause 22.3.20, “GetReplyExecCost”:
  - i) Without Feature M010, “Foreign-data wrapper support”, a conforming SQL-server shall not contain an invocation of a <foreign-data wrapper interface routine> that contains a <foreign-data wrapper interface routine name> that contains GetReplyExecCost.
- t) Subclause 22.3.21, “GetReplyFirstCost”:
  - i) Without Feature M010, “Foreign-data wrapper support”, a conforming SQL-server shall not contain an invocation of a <foreign-data wrapper interface routine> that contains a <foreign-data wrapper interface routine name> that contains GetReplyFirstCost.
- u) Subclause 22.3.22, “GetReplyOrderElem”:
  - i) Without Feature M010, “Foreign-data wrapper support”, a conforming SQL-server shall not contain an invocation of a <foreign-data wrapper interface routine> that contains a <foreign-data wrapper interface routine name> that contains GetReplyOrderElem.
- v) Subclause 22.3.23, “GetReplyReExecCost”:
  - i) Without Feature M010, “Foreign-data wrapper support”, a conforming SQL-server shall not contain an invocation of a <foreign-data wrapper interface routine> that contains a <foreign-data wrapper interface routine name> that contains GetReplyReExecCost.
- w) Subclause 22.3.24, “GetReplySelectElem”:
  - i) Without Feature M010, “Foreign-data wrapper support”, a conforming SQL-server shall not contain an invocation of a <foreign-data wrapper interface routine> that contains a <foreign-data wrapper interface routine name> that contains GetReplySelectElem.
- x) Subclause 22.3.25, “GetReplyTableRef”:
  - i) Without Feature M010, “Foreign-data wrapper support”, a conforming SQL-server shall not contain an invocation of a <foreign-data wrapper interface routine> that contains a <foreign-data wrapper interface routine name> that contains GetReplyTableRef.
- y) Subclause 22.3.26, “GetSPDHandle”:

- i) Without Feature M010, “Foreign-data wrapper support”, a conforming SQL-server shall not contain an invocation of a <foreign-data wrapper interface routine> that contains a <foreign-data wrapper interface routine name> that contains GetSPDHandle.
- z) Subclause 22.3.27, “GetSRDHandle”:
  - i) Without Feature M010, “Foreign-data wrapper support”, a conforming SQL-server shall not contain an invocation of a <foreign-data wrapper interface routine> that contains a <foreign-data wrapper interface routine name> that contains GetSRDHandle.
- aa) Subclause 22.3.29, “GetWPDHandle”:
  - i) Without Feature M010, “Foreign-data wrapper support”, a conforming SQL-server shall not contain an invocation of a <foreign-data wrapper interface routine> that contains a <foreign-data wrapper interface routine name> that contains GetWPDHandle.
- ab) Subclause 22.3.30, “GetWRDHandle”:
  - i) Without Feature M010, “Foreign-data wrapper support”, a conforming SQL-server shall not contain an invocation of a <foreign-data wrapper interface routine> that contains a <foreign-data wrapper interface routine name> that contains GetWRDHandle.
- ac) Subclause 22.3.31, “InitRequest”:
  - i) Without Feature M010, “Foreign-data wrapper support”, a conforming SQL-server shall not contain an invocation of a <foreign-data wrapper interface routine> that contains a <foreign-data wrapper interface routine name> that contains InitRequest.
- ad) Subclause 22.3.32, “Iterate”:
  - i) Without Feature M010, “Foreign-data wrapper support”, a conforming SQL-server shall not contain an invocation of a <foreign-data wrapper interface routine> that contains a <foreign-data wrapper interface routine name> that contains Iterate.
- ae) Subclause 22.3.33, “Open”:
  - i) Without Feature M010, “Foreign-data wrapper support”, a conforming SQL-server shall not contain an invocation of a <foreign-data wrapper interface routine> that contains a <foreign-data wrapper interface routine name> that contains Open.
- af) Subclause 22.3.34, “ReOpen”:
  - i) Without Feature M010, “Foreign-data wrapper support”, a conforming SQL-server shall not contain an invocation of a <foreign-data wrapper interface routine> that contains a <foreign-data wrapper interface routine name> that contains ReOpen.
- 11) Specifications for Feature M011, “Datalinks via Ada”:
  - a) Subclause 18.1, “<embedded SQL Ada program>”:
    - i) Without Feature M011, “Datalinks via Ada”, conforming SQL language shall not contain an <Ada DATALINK variable>.
- 12) Specifications for Feature M012, “Datalinks via C”:
  - a) Subclause 18.2, “<embedded SQL C program>”:

- i) Without Feature M012, “Datalinks via C”, conforming SQL language shall not contain a <C DATALINK variable>.
- 13) Specifications for Feature M013, “Datalinks via COBOL”:
- a) Subclause 18.3, “<embedded SQL COBOL program>”:
    - i) Without Feature M013, “Datalinks via COBOL”, conforming SQL language shall not contain a <COBOL DATALINK variable>.
- 14) Specifications for Feature M014, “Datalinks via Fortran”:
- a) Subclause 18.4, “<embedded SQL Fortran program>”:
    - i) Without Feature M014, “Datalinks via Fortran”, conforming SQL language shall not contain a <Fortran DATALINK variable>.
- 15) Specifications for Feature M015, “Datalinks via M”:
- a) Subclause 18.5, “<embedded SQL MUMPS program>”:
    - i) Without Feature M015, “Datalinks via M”, conforming SQL language shall not contain a <MUMPS DATALINK variable>.
- 16) Specifications for Feature M016, “Datalinks via Pascal”:
- a) Subclause 18.6, “<embedded SQL Pascal program>”:
    - i) Without Feature M016, “Datalinks via Pascal”, conforming SQL language shall not contain a <Pascal DATALINK variable>.
- 17) Specifications for Feature M017, “Datalinks via PL/I”:
- a) Subclause 18.7, “<embedded SQL PL/I program>”:
    - i) Without Feature M017, “Datalinks via PL/I”, conforming SQL language shall not contain a <PL/I DATALINK variable>.
- 18) Specifications for Feature M018, “Foreign-data wrapper interface routines in Ada”:
- a) Subclause 22.1, “<foreign-data wrapper interface routine>”:
    - i) Without Feature M018, “Foreign-data wrapper interface routines in Ada”, a conforming foreign-data wrapper shall not contain an invocation of a <foreign-data wrapper interface routine> written in Ada.
    - ii) Without Feature M018, “Foreign-data wrapper interface routines in Ada”, a conforming SQLserver shall not contain an invocation of a <foreign-data wrapper interface routine> written in Ada.
- 19) Specifications for Feature M019, “Foreign-data wrapper interface routines in C”:
- a) Subclause 22.1, “<foreign-data wrapper interface routine>”:
    - i) Without Feature M019, “Foreign-data wrapper interface routines in C”, a conforming foreign-data wrapper shall not contain an invocation of a <foreign-data wrapper interface routine> written in C.

- ii) Without Feature M019, “Foreign-data wrapper interface routines in C”, a conforming SQLserver shall not contain an invocation of a <foreign-data wrapper interface routine> written in C.

20) Specifications for Feature M020, “Foreign-data wrapper interface routines in COBOL”:

- a) Subclause 22.1, “<foreign-data wrapper interface routine>”:
  - i) Without Feature M020, “Foreign-data wrapper interface routines in COBOL”, a conforming foreign-data wrapper shall not contain an invocation of a <foreign-data wrapper interface routine> written in COBOL.
  - ii) Without Feature M020, “Foreign-data wrapper interface routines in COBOL”, a conforming SQL-server shall not contain an invocation of a <foreign-data wrapper interface routine> written in COBOL.

21) Specifications for Feature M021, “Foreign-data wrapper interface routines in Fortran”:

- a) Subclause 22.1, “<foreign-data wrapper interface routine>”:
  - i) Without Feature M021, “Foreign-data wrapper interface routines in Fortran”, a conforming foreign-data wrapper shall not contain an invocation of a <foreign-data wrapper interface routine> written in Fortran.
  - ii) Without Feature M021, “Foreign-data wrapper interface routines in Fortran”, a conforming SQL-server shall not contain an invocation of a <foreign-data wrapper interface routine> written in Fortran.

22) Specifications for Feature M022, “Foreign-data wrapper interface routines in MUMPS”:

- a) Subclause 22.1, “<foreign-data wrapper interface routine>”:
  - i) Without Feature M022, “Foreign-data wrapper interface routines in MUMPS”, a conforming foreign-data wrapper shall not contain an invocation of a <foreign-data wrapper interface routine> written in M.
  - ii) Without Feature M022, “Foreign-data wrapper interface routines in MUMPS”, a conforming SQL-server shall not contain an invocation of a <foreign-data wrapper interface routine> written in M.

23) Specifications for Feature M023, “Foreign-data wrapper interface routines in Pascal”:

- a) Subclause 22.1, “<foreign-data wrapper interface routine>”:
  - i) Without Feature M023, “Foreign-data wrapper interface routines in Pascal”, a conforming foreign-data wrapper shall not contain an invocation of a <foreign-data wrapper interface routine> written in Pascal.
  - ii) Without Feature M023, “Foreign-data wrapper interface routines in Pascal”, a conforming SQL-server shall not contain an invocation of a <foreign-data wrapper interface routine> written in Pascal.

24) Specifications for Feature M024, “Foreign-data wrapper interface routines in PL/I”:

- a) Subclause 22.1, “<foreign-data wrapper interface routine>”:
  - i) Without Feature M024, “Foreign-data wrapper interface routines in PL/I”, a conforming foreign-data wrapper shall not contain an invocation of a <foreign-data wrapper interface routine> written in PL/I.

- ii) Without Feature M024, “Foreign-data wrapper interface routines in PL/I”, a conforming SQLserver shall not contain an invocation of a <foreign-data wrapper interface routine> written in PL/I.

25) Specifications for Feature M030, “SQL-server foreign data support”:

- a) Subclause 22.4.1, “AllocDescriptor”:
  - i) Without Feature M030, “SQL-server foreign data support”, a conforming foreign-data wrapper shall not contain an invocation of a <foreign-data wrapper interface routine> that contains a <foreign-data wrapper interface routine name> that contains AllocDescriptor.
- b) Subclause 22.4.2, “FreeDescriptor”:
  - i) Without Feature M030, “SQL-server foreign data support”, a conforming foreign-data wrapper shall not contain an invocation of a <foreign-data wrapper interface routine> that contains a <foreign-data wrapper interface routine name> that contains FreeDescriptor.
- c) Subclause 22.4.3, “GetAuthorizationId”:
  - i) Without Feature M030, “SQL-server foreign data support”, a conforming foreign-data wrapper shall not contain an invocation of a <foreign-data wrapper interface routine> that contains a <foreign-data wrapper interface routine name> that contains GetAuthorizationId.
- d) Subclause 22.4.4, “GetBoolVE”:
  - i) Without Feature M030, “SQL-server foreign data support”, a conforming foreign-data wrapper shall not contain an invocation of a <foreign-data wrapper interface routine> that contains a <foreign-data wrapper interface routine name> that contains GetBoolVE.
- e) Subclause 22.4.5, “GetDescriptor”:
  - i) Without Feature M030, “SQL-server foreign data support”, a conforming foreign-data wrapper shall not contain an invocation of a <foreign-data wrapper interface routine> that contains a <foreign-data wrapper interface routine name> that contains GetDescriptor.
- f) Subclause 22.4.6, “GetDistinct”:
  - i) Without Feature M030, “SQL-server foreign data support”, a conforming foreign-data wrapper shall not contain an invocation of a <foreign-data wrapper interface routine> that contains a <foreign-data wrapper interface routine name> that contains GetDistinct.
- g) Subclause 22.4.7, “GetNumBoolVE”:
  - i) Without Feature M030, “SQL-server foreign data support”, a conforming foreign-data wrapper shall not contain an invocation of a <foreign-data wrapper interface routine> that contains a <foreign-data wrapper interface routine name> that contains GetNumBoolVE.
- h) Subclause 22.4.8, “GetNumChildren”:
  - i) Without Feature M030, “SQL-server foreign data support”, a conforming foreign-data wrapper shall not contain an invocation of a <foreign-data wrapper interface routine> that contains a <foreign-data wrapper interface routine name> that contains GetNumChildren.
- i) Subclause 22.4.9, “GetNumOrderByElems”:

- i) Without Feature M030, “SQL-server foreign data support”, a conforming foreign-data wrapper shall not contain an invocation of a <foreign-data wrapper interface routine> that contains a <foreign-data wrapper interface routine name> that contains GetNumOrderByElems.
- j) Subclause 22.4.10, “GetNumRoutMapOpts”:
  - i) Without Feature M030, “SQL-server foreign data support”, a conforming foreign-data wrapper shall not contain an invocation of a <foreign-data wrapper interface routine> that contains a <foreign-data wrapper interface routine name> that contains GetNumRoutMapOpts.
- k) Subclause 22.4.11, “GetNumSelectElems”:
  - i) Without Feature M030, “SQL-server foreign data support”, a conforming foreign-data wrapper shall not contain an invocation of a <foreign-data wrapper interface routine> that contains a <foreign-data wrapper interface routine name> that contains GetNumSelectElems.
- l) Subclause 22.4.12, “GetNumServerOpts”:
  - i) Without Feature M030, “SQL-server foreign data support”, a conforming foreign-data wrapper shall not contain an invocation of a <foreign-data wrapper interface routine> that contains a <foreign-data wrapper interface routine name> that contains GetNumServerOpts.
- m) Subclause 22.4.13, “GetNumTableColOpts”:
  - i) Without Feature M030, “SQL-server foreign data support”, a conforming foreign-data wrapper shall not contain an invocation of a <foreign-data wrapper interface routine> that contains a <foreign-data wrapper interface routine name> that contains GetNumTableColOpts.
- n) Subclause 22.4.14, “GetNumTableOpts”:
  - i) Without Feature M030, “SQL-server foreign data support”, a conforming foreign-data wrapper shall not contain an invocation of a <foreign-data wrapper interface routine> that contains a <foreign-data wrapper interface routine name> that contains GetNumTableOpts.
- o) Subclause 22.4.15, “GetNumTableRefElems”:
  - i) Without Feature M030, “SQL-server foreign data support”, a conforming foreign-data wrapper shall not contain an invocation of a <foreign-data wrapper interface routine> that contains a <foreign-data wrapper interface routine name> that contains GetNumTableRefElems.
- p) Subclause 22.4.16, “GetNumUserOpts”:
  - i) Without Feature M030, “SQL-server foreign data support”, a conforming foreign-data wrapper shall not contain an invocation of a <foreign-data wrapper interface routine> that contains a <foreign-data wrapper interface routine name> that contains GetNumUserOpts.
- q) Subclause 22.4.17, “GetNumWrapperOpts”:
  - i) Without Feature M030, “SQL-server foreign data support”, a conforming foreign-data wrapper shall not contain an invocation of a <foreign-data wrapper interface routine> that contains a <foreign-data wrapper interface routine name> that contains GetNumWrapperOpts.
- r) Subclause 22.4.18, “GetOrderByElem”:
  - i) Without Feature M030, “SQL-server foreign data support”, a conforming foreign-data wrapper shall not contain an invocation of a <foreign-data wrapper interface routine> that contains a <foreign-data wrapper interface routine name> that contains GetOrderByElem.

- s) Subclause 22.4.19, “GetRoutMapOpt”:
  - i) Without Feature M030, “SQL-server foreign data support”, a conforming foreign-data wrapper shall not contain an invocation of a <foreign-data wrapper interface routine> that contains a <foreign-data wrapper interface routine name> that contains GetRoutMapOpt.
- t) Subclause 22.4.20, “GetRoutMapOptName”:
  - i) Without Feature M030, “SQL-server foreign data support”, a conforming foreign-data wrapper shall not contain an invocation of a <foreign-data wrapper interface routine> that contains a <foreign-data wrapper interface routine name> that contains GetRoutMapOptName.
- u) Subclause 22.4.21, “GetRoutineMapping”:
  - i) Without Feature M030, “SQL-server foreign data support”, a conforming foreign-data wrapper shall not contain an invocation of a <foreign-data wrapper interface routine> that contains a <foreign-data wrapper interface routine name> that contains GetRoutineMapping.
- v) Subclause 22.4.22, “GetSelectElem”:
  - i) Without Feature M030, “SQL-server foreign data support”, a conforming foreign-data wrapper shall not contain an invocation of a <foreign-data wrapper interface routine> that contains a <foreign-data wrapper interface routine name> that contains GetSelectElem.
- w) Subclause 22.4.23, “GetSelectElemType”:
  - i) Without Feature M030, “SQL-server foreign data support”, a conforming foreign-data wrapper shall not contain an invocation of a <foreign-data wrapper interface routine> that contains a <foreign-data wrapper interface routine name> that contains GetSelectElemType.
- x) Subclause 22.4.24, “GetServerName”:
  - i) Without Feature M030, “SQL-server foreign data support”, a conforming foreign-data wrapper shall not contain an invocation of a <foreign-data wrapper interface routine> that contains a <foreign-data wrapper interface routine name> that contains GetServerName.
- y) Subclause 22.4.25, “GetServerOpt”:
  - i) Without Feature M030, “SQL-server foreign data support”, a conforming foreign-data wrapper shall not contain an invocation of a <foreign-data wrapper interface routine> that contains a <foreign-data wrapper interface routine name> that contains GetServerOpt.
- z) Subclause 22.4.26, “GetServerOptByName”:
  - i) Without Feature M030, “SQL-server foreign data support”, a conforming foreign-data wrapper shall not contain an invocation of a <foreign-data wrapper interface routine> that contains a <foreign-data wrapper interface routine name> that contains GetServerOptByName.
- aa) Subclause 22.4.27, “GetServerType”:
  - i) Without Feature M030, “SQL-server foreign data support”, a conforming foreign-data wrapper shall not contain an invocation of a <foreign-data wrapper interface routine> that contains a <foreign-data wrapper interface routine name> that contains GetServerType.
- ab) Subclause 22.4.28, “GetServerVersion”:

- i) Without Feature M030, “SQL-server foreign data support”, a conforming foreign-data wrapper shall not contain an invocation of a <foreign-data wrapper interface routine> that contains a <foreign-data wrapper interface routine name> that contains GetServerVersion.
- ac) Subclause 22.4.30, “GetTableColOpt”:
  - i) Without Feature M030, “SQL-server foreign data support”, a conforming foreign-data wrapper shall not contain an invocation of a <foreign-data wrapper interface routine> that contains a <foreign-data wrapper interface routine name> that contains GetTableColOpt.
- ad) Subclause 22.4.31, “GetTableColOptByName”:
  - i) Without Feature M030, “SQL-server foreign data support”, a conforming foreign-data wrapper shall not contain an invocation of a <foreign-data wrapper interface routine> that contains a <foreign-data wrapper interface routine name> that contains GetTableColOptByName.
- ae) Subclause 22.4.32, “GetTableOpt”:
  - i) Without Feature M030, “SQL-server foreign data support”, a conforming foreign-data wrapper shall not contain an invocation of a <foreign-data wrapper interface routine> that contains a <foreign-data wrapper interface routine name> that contains GetTableOpt.
- af) Subclause 22.4.33, “GetTableOptByName”:
  - i) Without Feature M030, “SQL-server foreign data support”, a conforming foreign-data wrapper shall not contain an invocation of a <foreign-data wrapper interface routine> that contains a <foreign-data wrapper interface routine name> that contains GetTableOptByName.
- ag) Subclause 22.4.34, “GetTableRefElem”:
  - i) Without Feature M030, “SQL-server foreign data support”, a conforming foreign-data wrapper shall not contain an invocation of a <foreign-data wrapper interface routine> that contains a <foreign-data wrapper interface routine name> that contains GetTableRefElem.
- ah) Subclause 22.4.35, “GetTableRefElemType”:
  - i) Without Feature M030, “SQL-server foreign data support”, a conforming foreign-data wrapper shall not contain an invocation of a <foreign-data wrapper interface routine> that contains a <foreign-data wrapper interface routine name> that contains GetTableRefElemType.
- ai) Subclause 22.4.36, “GetTableRefTableName”:
  - i) Without Feature M030, “SQL-server foreign data support”, a conforming foreign-data wrapper shall not contain an invocation of a <foreign-data wrapper interface routine> that contains a <foreign-data wrapper interface routine name> that contains GetTableRefTableName.
- aj) Subclause 22.4.37, “GetTableServerName”:
  - i) Without Feature M030, “SQL-server foreign data support”, a conforming foreign-data wrapper shall not contain an invocation of a <foreign-data wrapper interface routine> that contains a <foreign-data wrapper interface routine name> that contains GetTableServerName.
- ak) Subclause 22.4.38, “GetTRDHandle”:
  - i) Without Feature M030, “SQL-server foreign data support”, a conforming foreign-data wrapper shall not contain an invocation of a <foreign-data wrapper interface routine> that contains a <foreign-data wrapper interface routine name> that contains GetTRDHandle.



- al) Subclause 22.4.39, “GetUserOpt”:
  - i) Without Feature M030, “SQL-server foreign data support”, a conforming foreign-data wrapper shall not contain an invocation of a <foreign-data wrapper interface routine> that contains a <foreign-data wrapper interface routine name> that contains GetUserOpt.
- am) Subclause 22.4.40, “GetUserOptByName”:
  - i) Without Feature M030, “SQL-server foreign data support”, a conforming foreign-data wrapper shall not contain an invocation of a <foreign-data wrapper interface routine> that contains a <foreign-data wrapper interface routine name> that contains GetUserOptByName.
- an) Subclause 22.4.41, “GetValExprColName”:
  - i) Without Feature M030, “SQL-server foreign data support”, a conforming foreign-data wrapper shall not contain an invocation of a <foreign-data wrapper interface routine> that contains a <foreign-data wrapper interface routine name> that contains GetValExprColName.
- ao) Subclause 22.4.42, “GetValueExpDesc”:
  - i) Without Feature M030, “SQL-server foreign data support”, a conforming foreign-data wrapper shall not contain an invocation of a <foreign-data wrapper interface routine> that contains a <foreign-data wrapper interface routine name> that contains GetValueExpDesc.
- ap) Subclause 22.4.43, “GetValueExpKind”:
  - i) Without Feature M030, “SQL-server foreign data support”, a conforming foreign-data wrapper shall not contain an invocation of a <foreign-data wrapper interface routine> that contains a <foreign-data wrapper interface routine name> that contains GetValueExpKind.
- aq) Subclause 22.4.44, “GetValueExpName”:
  - i) Without Feature M030, “SQL-server foreign data support”, a conforming foreign-data wrapper shall not contain an invocation of a <foreign-data wrapper interface routine> that contains a <foreign-data wrapper interface routine name> that contains GetValueExpName.
- ar) Subclause 22.4.45, “GetValueExpTable”:
  - i) Without Feature M030, “SQL-server foreign data support”, a conforming foreign-data wrapper shall not contain an invocation of a <foreign-data wrapper interface routine> that contains a <foreign-data wrapper interface routine name> that contains GetValueExpTable.
- as) Subclause 22.4.46, “GetVEChild”:
  - i) Without Feature M030, “SQL-server foreign data support”, a conforming foreign-data wrapper shall not contain an invocation of a <foreign-data wrapper interface routine> that contains a <foreign-data wrapper interface routine name> that contains GetVEChild.
- at) Subclause 22.4.47, “GetWrapperLibraryName”:
  - i) Without Feature M030, “SQL-server foreign data support”, a conforming foreign-data wrapper shall not contain an invocation of a <foreign-data wrapper interface routine> that contains a <foreign-data wrapper interface routine name> that contains GetWrapperLibraryName.
- au) Subclause 22.4.48, “GetWrapperName”:

- i) Without Feature M030, “SQL-server foreign data support”, a conforming foreign-data wrapper shall not contain an invocation of a <foreign-data wrapper interface routine> that contains a <foreign-data wrapper interface routine name> that contains GetWrapperName.

av) Subclause 22.4.49, “GetWrapperOpt”:

- i) Without Feature M030, “SQL-server foreign data support”, a conforming foreign-data wrapper shall not contain an invocation of a <foreign-data wrapper interface routine> that contains a <foreign-data wrapper interface routine name> that contains GetWrapperOpt.

aw) Subclause 22.4.50, “GetWrapperOptByName”:

- i) Without Feature M030, “SQL-server foreign data support”, a conforming foreign-data wrapper shall not contain an invocation of a <foreign-data wrapper interface routine> that contains a <foreign-data wrapper interface routine name> that contains GetWrapperOptByName.

ax) Subclause 22.4.51, “SetDescriptor”:

- i) Without Feature M030, “SQL-server foreign data support”, a conforming foreign-data wrapper shall not contain an invocation of a <foreign-data wrapper interface routine> that contains a <foreign-data wrapper interface routine name> that contains SetDescriptor.

26) Specifications for Feature M031, “Foreign-data wrapper general routines”:

a) Subclause 22.5.1, “GetDiagnostics”:

- i) Without Feature M031, “Foreign-data wrapper general routines”, a conforming foreign-data wrapper shall not contain an invocation of a <foreign-data wrapper interface routine> that contains a <foreign-data wrapper interface routine name> that contains AllocQueryContext.
- ii) Without Feature M031, “Foreign-data wrapper general routines”, a conforming SQL-server shall not contain an invocation of a <foreign-data wrapper interface routine> that contains a <foreign-data wrapper interface routine name> that contains GetDiagnostics.

*(Blank page)*

## Annex B (informative)

### Implementation-defined elements

*This Annex modifies Annex B, “Implementation-defined elements”, in ISO/IEC 9075-2.*

This Annex references those features that are identified in the body of this part of ISO/IEC 9075 as implementation-defined.

- 1) Subclause 4.2, “Foreign servers”:
  - a) The possible values of server type and server version, and their meanings, are implementation-defined.
- 2) Subclause 4.6, “Generic options”:
  - a) Both the option name and the option value of a generic option are implementation-defined.
- 3) Subclause 4.7, “Capabilities and options information”:
  - a) The manner in which an external DTD is made available to the SQL-server is implementation-dependent.
- 4) Insert this list element Subclause 4.8, “Datalinks”:
  - a) The time at which a valid access token ceases to be valid is implementation-defined.
  - b) The datalink character set is implementation-defined.
  - c) The implementation-defined *maximum datalink length* determines the amount of space, in octets, that is allocated for:
    - A host variable of data type DATALINK.
    - An argument of declared type DATALINK to an invocation of an external routine.
    - The value returned by an invocation of an external function whose result type is DATALINK.

The maximum datalink length constrains the values of expressions whose declared type is DATALINK such that every such value can be assigned to a host variable, substituted for a parameter to an external routine, or returned by an invocation of an external function.
- 5) Subclause 4.17.1, “Handles”:
  - a) The validity of a handle in a compilation unit other than the one in which the identified resource was allocated is implementation-defined.
- 6) Subclause 4.17.5, “Foreign-data wrapper diagnostics areas”:
  - a) If the routine's return code indicates **No data found**, then no status record is generated corresponding to SQLSTATE value '02000' but there may be status records generated corresponding to SQLSTATE value '02nnn', where 'nnn' is an implementation-defined subclass value.

7) Subclause 5.2, “Names and identifiers”:

- a) Equivalence of two <option name>s is determined using an implementation-defined collation that is sensitive to case.

8) Subclause 6.4, “<string value function>”:

- a) If <url complete expression> is specified, then the data type of the result is a variable-length character string with an implementation-defined maximal length.
- b) If <url path expression> is specified, then the data type of the result is a variable-length character string with an implementation-defined maximal length.
- c) If <url path only expression> is specified, then the data type of the result is a variable-length character string with an implementation-defined maximal length.
- d) If <url scheme expression> is specified, then the data type of the result is a variable-length character string with an implementation-defined maximal length.
- e) If <url server expression> is specified, then the data type of the result is a variable-length character string with an implementation-defined maximal length.
- f) If <url complete for write expression> is specified, then the data type of the result is a variable-length character string with an implementation-defined maximal length.
- g) If <url complete only expression> is specified, then the data type of the result is a variable-length character string with an implementation-defined maximal length.
- h) If <url path for write expression> is specified, then the data type of the result is a variable-length character string with an implementation-defined maximal length.

9) Subclause 6.6, “<datalink value function>”:

- a) The format of *DLOC* may be implementation-defined.
- b) The scheme of *DL*, the host of *DL*, and the path of *DL* may be implementation-defined.
- c) If *TIV* is equal to 1 (one) and if the write token included in *DLOC* does not conform to implementation-defined requirements, then an exception condition is raised: *datalink exception — invalid write token*.

10) Subclause 11.14, “<foreign table definition>”:

- a) If <basic column definition list> is specified, then the nullability characteristic and <default option> of each column specified by <basic column definition> is implementation-defined.
- b) If <basic column definition list> is not specified, then column descriptors included in a foreign table descriptor are implementation-defined.
- c) Additional privileges, if any, necessary to execute <foreign table definition> are implementation-defined.

11) Subclause 11.15, “<alter foreign table statement>”:

- a) If <alter generic options> is specified, then any effect on the foreign table descriptor, apart from its generic options descriptor, is implementation-defined.

12) Subclause 11.16, “<add basic column definition>”:

- a) The nullability characteristic and <default option> included in the column descriptor specified by <basic column definition> is implementation-defined.
- 13) Subclause 12.1, “<foreign server definition>”:
- a) The permissible Format and values for <server type> and <server version> are implementation-defined.
  - b) Additional privileges, if any, necessary to execute <foreign server definition> are implementation-defined.
- 14) Subclause 12.4, “<foreign-data wrapper definition>”:
- a) The privileges necessary to execute <foreign-data wrapper definition> are implementation-defined.
- 15) Subclause 13.3, “<user mapping definition>”:
- a) Additional privileges, if any, necessary to execute <user mapping definition> are implementation-defined.
- 16) Subclause 13.4, “<alter user mapping statement>”:
- a) The privileges necessary to execute <alter user mapping statement> are implementation-defined.
- 17) Subclause 13.5, “<drop user mapping statement>”:
- a) The privileges necessary to execute <drop user mapping statement> are implementation-defined.
- 18) Subclause 12.8, “<routine mapping definition>”:
- a) Additional privileges, if any, necessary to execute <routine mapping definition> are implementation-defined.
- 19) Subclause 12.9, “<alter routine mapping statement>”:
- a) The privileges necessary to execute <alter routine mapping statement> are implementation-defined.
- 20) Subclause 12.10, “<drop routine mapping statement>”:
- a) The privileges necessary to execute <drop routine mapping statement> are implementation-defined.
- 21) Subclause 15.3, “Effect of replacing rows in base tables”:
- a) If the Construction Indication of *DLCV2* is either *NEWCOPY* or *PREVIOUSCOPY*, and if the write permission option included in the descriptor of *DLC* is *ADMIN REQUIRING TOKEN FOR UPDATE*, and if the Write Token of *DLCV2* is not valid according to implementation-defined rules, then an exception condition is raised: *datalink exception — invalid write token*.
- 22) Subclause 17.4, “<describe statement>”:
- If *TYPE* indicates *DATALINK*, then *LENGTH* is set to the length of maximum length in characters of the character string; *OCTET\_LENGTH* is set to the maximum possible length in octets of the character string; *CHARACTER\_SET\_CATALOG*, *CHARACTER\_SET\_SCHEMA*, and *CHARACTER\_SET\_NAME* are set to the <character set name> of the character string's character set; and the <collation name> of the character string's collation. If the subject <language clause> specifies *C*, then the lengths specified in *LENGTH* and *OCTET\_LENGTH* do not include the implementation-defined null character that terminates a *C* character string.
- 23) Subclause 20.1, “BuildDataLink”:
- a) The maximum length of a variable length character string is implementation-defined.

b) The maximum length of a datalink is implementation-defined.

24) Subclause 20.2, “GetDataLinkAttr”:

a) The maximum length of a datalink is implementation-defined.

25) Subclause 21.1, “Description of foreign-data wrapper item descriptor areas”:

- a) Let *IDA* be an item descriptor area in a wrapper parameter descriptor. One condition that allows *IDA* to be valid is if *TYPE* indicates an implementation-defined data type.
- b) One condition that allows a foreign-data wrapper item descriptor area in a foreign-data wrapper descriptor area that is not a wrapper row descriptor to be consistent is if *TYPE* indicates an implementation-defined data type.
- c) Let *IDA* be an item descriptor area in a server parameter descriptor. One condition that allows *IDA* to be valid is if *TYPE* indicates an implementation-defined data type.
- d) One condition that allows a foreign-data wrapper item descriptor area in a server row descriptor to be valid is if *TYPE* indicates an implementation-defined data type.

26) Subclause 21.6, “Implicit FETCH USING clause”:

a) If the result is a zero-length character string, then it is implementation-defined whether or not an exception condition is raised: *data exception — zero-length character string*.

27) Subclause 22.1, “<foreign-data wrapper interface routine>”:

a) It is implementation-defined which of the invocation of *WP* or *WF* is supported.

28) Subclause 22.2, “<foreign-data wrapper interface routine> invocation”:

- a) If the value of any input argument provided by *CP* falls outside the set of allowed values of the data type of the parameter, or if the value of any output argument resulting from the execution of the <foreign-data wrapper interface routine> falls outside the set of values supported by *CP* for that parameter, then the effect is implementation-defined.
- b) If *RN* did not execute successfully, then one or more exception conditions may be raised as determined by implementation-defined rules.

29) Subclause 22.3.2, “AllocQueryContext”:

a) If the resources to manage a query context cannot be allocated for foreign-data wrapper implementation-defined reasons, then an implementation-defined exception condition is raised.

30) Subclause 22.3.3, “AllocWrapperEnv”:

- a) The maximum number of foreign-data wrapper environments is implementation-defined.
- b) If the resources to manage a foreign-data wrapper environment cannot be allocated for implementation-defined reasons, then an implementation-defined exception condition is raised.

31) Subclause 22.3.5, “ConnectServer”:

- a) The maximum number of FS-connections is implementation-defined.
- b) If the resources to manage an FS-connection cannot be allocated for implementation-defined reasons, then an implementation-defined exception condition is raised.

- 32) Subclause 22.3.16, “GetOpts”:
- a) The CDATA values of the SQLMEDOptionName attribute and the PCDATA text of the SQLMED-GenericOption tag are implementation-defined.
  - b) The way in which the foreign-data wrapper knows the URI to specify in the XML document is implementation-defined.
- 33) Subclause 22.4.19, “GetRoutMapOpt”:
- a) The maximum length of a variable-length character string is implementation-defined.
- 34) Subclause 22.4.20, “GetRoutMapOptName”:
- a) The maximum length of a variable-length character string is implementation-defined.
- 35) Subclause 22.3.28, “GetStatistics”:
- a) The CDATA values of the SQLMEDStatisticName attribute and the PCDATA text of the SQLMED-Statistics tag are implementation-defined.
  - b) The way in which the foreign-data wrapper knows the URI to specify in the XML document is implementation-defined.
- 36) Subclause 22.3.31, “InitRequest”:
- a) The maximum number of FDW-replies is implementation-defined.
  - b) If the resources to manage an FDW-reply cannot be allocated for implementation-defined reasons, then an implementation-defined exception condition is raised.
  - c) The maximum number of FDW-executions is implementation-defined.
  - d) If the resources to manage an FDW-execution cannot be allocated for implementation-defined reasons, then an implementation-defined exception condition is raised.
- 37) Subclause 22.3.32, “Iterate”:
- a) If the resources to manage an FDW-data cannot be allocated for implementation-defined reasons, then an implementation-defined exception condition is raised.
- 38) Subclause 22.3.35, “TransmitRequest”:
- a) The maximum number of FDW-executions is implementation-defined.
- 39) Subclause 22.4.1, “AllocDescriptor”:
- a) The maximum number of foreign-data descriptor areas is implementation-defined.
- 40) Subclause 22.4.5, “GetDescriptor”:
- a) If TYPE is 'HEADER', then header information from the descriptor area *D* is retrieved; if *FI* indicates an implementation-defined descriptor header field, then the value retrieved is the value of the implementation-defined descriptor header field identified by *FI*.
  - b) If TYPE is 'ITEM', then item information from the descriptor area *D* is retrieved; if *FI* indicates an implementation-defined descriptor item field, then the value retrieved is the value of the implementation-defined descriptor item field of *IDA* identified by *FI*.



41) Subclause 22.4.12, “GetNumServerOpts”:

- a) The maximum length of a variable-length character string is implementation-defined.

42) Subclause 22.4.24, “GetServerName”:

- a) The maximum length of a variable-length character string is implementation-defined.

43) Subclause 22.4.25, “GetServerOpt”:

- a) The maximum length of a variable-length character string is implementation-defined.

44) Subclause 22.4.26, “GetServerOptByName”:

- a) The maximum length of a variable-length character string is implementation-defined.

45) Subclause 22.4.27, “GetServerType”:

- a) The maximum length of a variable-length character string is implementation-defined.

46) Subclause 22.4.36, “GetTableRefTableName”:

- a) The maximum length of a variable-length character string is implementation-defined.

47) Subclause 22.4.41, “GetValExprColName”:

- a) The maximum length of a variable-length character string is implementation-defined.

48) Subclause 22.4.44, “GetValueExpName”:

- a) The maximum length of a variable-length character string is implementation-defined.

49) Subclause 22.4.51, “SetDescriptor”:

- a) If *FI* indicates TYPE and *V* indicates NUMERIC or DECIMAL, then the SCALE field of *IDA* is set to 0 (zero) and the PRECISION field of *IDA* is set to the implementation-defined default value for the precision of NUMERIC or DECIMAL data types, respectively.
- b) If *FI* indicates TYPE and *V* indicates SMALLINT, INTEGER, or BIGINT, then the SCALE field of *IDA* is set to 0 (zero) and the PRECISION field of *IDA* is set to the implementation-defined value for the precision of the SMALLINT, INTEGER, or BIGINT data types, respectively.
- c) If *FI* indicates TYPE and *V* indicates FLOAT, then the PRECISION field of *IDA* is set to the implementation-defined default value for the precision of the FLOAT data type.
- d) If *FI* indicates TYPE and *V* indicates REAL or DOUBLE PRECISION, then the PRECISION field of *IDA* is set to the implementation-defined value for the precision of the REAL or DOUBLE PRECISION data types, respectively.
- e) If *FI* indicates TYPE and *V* indicates an implementation-defined data type, then an implementation-defined set of fields of *IDA* are set to implementation-defined default values.

50) Subclause 22.5.1, “GetDiagnostics”:

- a) If *TYPE* is 'HEADER' and *DI* indicates an implementation-defined diagnostics header field, then the value retrieved is the value of the implementation-defined diagnostics header field.
- b) If *TYPE* is 'STATUS' and *DI* indicates an implementation-defined diagnostics header field, then the value retrieved is the value of the implementation-defined diagnostics header field.

- c) If *TYPE* is 'STATUS' and *DI* indicates NATIVE\_CODE, then the value retrieved is the implementation-defined native error code corresponding to the status condition.
- d) If *TYPE* is 'STATUS' and *DI* indicates MESSAGE\_TEXT, then the value retrieved is an implementation-defined character string.
- e) If *TYPE* is 'STATUS' and *DI* indicates CLASS\_ORIGIN, then the value retrieved shall be an implementation-defined character string other than 'ISO 9075' for any implementation-defined class value.
- f) If *TYPE* is 'STATUS' and *DI* indicates SUBCLASS\_ORIGIN, then the value retrieved shall be an implementation-defined character string other than 'ISO 9075' for any implementation-defined subclass value.

51) Table 3, “Fields used in foreign-data wrapper diagnostics areas”:

- a) The maximum lengths of foreign-data wrapper diagnostics area fields whose data types are CHARACTER VARYING are implementation-defined.
- b) SQL/MED supports implementation-defined header fields in foreign-data wrapper diagnostics areas.

52) Table 4, “Fields in foreign-data wrapper descriptor areas”:

- a) The maximum lengths of foreign-data wrapper item descriptor fields whose data type is CHARACTER VARYING are implementation-defined.
- b) SQL/MED supports implementation-defined header fields and implementation-defined item fields in row and parameter descriptor areas.

53) Table 29, “Codes used for foreign-data wrapper diagnostic fields”:

- a) SQL/MED supports implementation-defined diagnostics header fields and implementation-defined diagnostics status fields.

54) Table 30, “Codes used for foreign-data wrapper descriptor fields”:

- a) SQL/MED supports implementation-defined descriptor header fields and implementation-defined descriptor item fields.

55) Table 32, “Ability to retrieve foreign-data wrapper descriptor fields”:

- a) 'ID' means that it is implementation-defined whether or not the descriptor field identified in a given row of this table is retrievable.
- b) SQL/MED supports implementation-defined descriptor header fields and implementation-defined descriptor item fields.

56) Table 33, “Ability to set foreign-data wrapper descriptor fields”:

- a) 'ID' means that it is implementation-defined whether or not the descriptor field is settable.
- b) SQL/MED supports implementation-defined descriptor header fields and implementation-defined descriptor item fields.

57) Table 34, “Foreign-data wrapper descriptor field default values”:

- a) 'ID' means that the default value of the descriptor field in the identified row is implementation-defined.
- b) SQL/MED supports implementation-defined descriptor header fields and implementation-defined descriptor item fields.

*(Blank page)*

## Annex C

### (informative)

### Implementation-dependent elements

*This Annex modifies Annex C, “Implementation-dependent elements”, in ISO/IEC 9075-2.*

This Annex references those places where this part of ISO/IEC 9075 states explicitly that the actions of a conforming implementation are implementation-dependent.

- 1) Subclause 4.2, “Foreign servers”:
  - a) The manner in which the SQL-server interacts with a foreign-data wrapper to import information about a foreign schema is implementation-dependent.
- 2) Subclause 4.8, “Datalinks”:
  - a) The Write Token of a datalink value is an implementation-dependent value.
  - b) The mechanism by which the SQL-server controls access and maintains integrity of files is implementation-dependent. This mechanism is called the *datalinker*.
  - c) The generation of the access token and the method of combining it with File Reference are implementation-dependent.
- 3) Subclause 4.17.1, “Handles”:
  - a) It is foreign-data wrapper implementation-dependent whether a foreign-data wrapper uses the information about the query context provided by the query context handle to re-use the previously evaluated value expression.
- 4) Subclause 4.17.4, “Return codes”:
  - a) After the execution of a foreign-data wrapper interface routine, the values of all output arguments not explicitly defined by this part of ISO/IEC 9075 are implementation-dependent.
- 5) Subclause 4.17.5, “Foreign-data wrapper diagnostics areas”:
  - a) If multiple status records are generated, then the order in which status records are placed in a diagnostics area is implementation-dependent, with two exceptions.
- 6) Subclause 6.4, “<string value function>”:
  - a) The generation of the access token and the method of combining it with File Reference or the <hpath> or <fpath> of a File Reference are implementation-dependent.
- 7) Subclause 6.6, “<datalink value function>”:
  - a) The representation of the result of invoking a <datalink value constructor> is implementation-dependent.
- 8) Subclause 7.1, “<table reference>”:

- a) In the <query specification> of the form “SELECT *DistinctOrAll*  $exp_1, exp_2, \dots, exp_n$  FROM  $FTN_1, FTN_2, \dots, FTN_m$  WHERE  $BVE_1$  AND  $BVE_2$  AND ... AND  $BVE_p$ ”,  $n, m,$  and  $p$  are implementation-dependent numeric values, and for all  $i, 1$  (one)  $\leq i \leq n, exp_i$  is an implementation-dependent <value expression> that does not generally contain a <subquery>.
  - b) It is implementation-dependent whether the `NextReply()` routine is invoked.
  - c) It is implementation-dependent whether General Rules 1)b)iv) through 1)b)xxxii) of Subclause 7.1, “<table reference>”, are applied more than once.
- 9) Subclause 17.5, “<input using clause>”:
- a) If <using arguments> is specified, then all fields, except DATA and DATA\_POINTER, in the  $i$ -th item descriptor area of *SPD*, that can be set according to Table 33, “Ability to set foreign-data wrapper descriptor fields”, are set to implementation-dependent values.
- 10) Subclause 21.3, “Implicit DESCRIBE INPUT USING clause”:
- a) If  $D$  is not zero, then those fields whose values depend on a value of TYPE and fields that are not applicable for a particular value of TYPE are set to implementation-dependent values.
- 11) Subclause 21.4, “Implicit DESCRIBE OUTPUT USING clause”:
- a) If  $D$  is not zero and the column name is implementation-dependent, then NAME is set to the implementation-dependent name of the column and UNNAMED is set to 1 (one).
  - b) If the name of the field is implementation-dependent, then NAME is set to the implementation-dependent name of the field and UNNAMED is set to 1 (one).
- 12) Subclause 21.6, “Implicit FETCH USING clause”:
- a) If *TDT* is a locator type and *SV* is not the null value, then a locator  $L$  that uniquely identifies *SV* is generated and the value  $TV$  of the  $i$ -th bound target is set to an implementation-dependent four-octet value that represents  $L$ .
  - b) If TYPE indicates ROW and  $TV$  is the null value, then the value of  $IP$  for *IDA* and that in all subordinate descriptor areas of *IDA* that are not subordinate to an item descriptor area whose TYPE indicates ARRAY, ARRAY LOCATOR, MULTISSET, or MULTISSET LOCATOR, is set to the appropriate 'Code' for SQL NULL DATA in Table 26, “Miscellaneous codes used in CLI”, in ISO/IEC 9075-3, and the value of the host variable addressed by  $DP$  and the values of  $D$  and of  $LP$  are implementation-dependent.
  - c) If TYPE does not indicate ROW and  $TV$  is the null value, then the value of  $IP$  is set to the appropriate 'Code' for SQL NULL DATA in Table 26, “Miscellaneous codes used in CLI”, in ISO/IEC 9075-3, and the value of the host variable addressed by  $DP$  and the values of  $D$  and of  $LP$  are implementation-dependent.
- 13) Subclause 21.8, “Binary large object string retrieval”:
- a) If  $TT$  indicates BINARY LARGE OBJECT and  $L$  is not greater than  $TL$ , then the first  $L$  octets of  $T$  are set to  $V$  and the values of the remaining octets of  $T$  are implementation-dependent.
- 14) Subclause 22.2, “<foreign-data wrapper interface routine> invocation”:
- a) If  $RN$  is a foreign-data wrapper interface wrapper routine, then the actions of invoking the SQL-server in response to the failed execution of  $RN$  are implementation-dependent.

## 15) Subclause 22.3.2, “AllocQueryContext”:

- a) If the foreign-data wrapper implementation-dependent maximum number of query contexts that can be allocated at one time has already been reached, then an exception condition is raised: *FDW-specific condition — limit on number of handles exceeded*.

## 16) Subclause 22.3.1, “AdvanceInitRequest”:

- a) The reply handle and the execution handle that are returned by this routine are chosen in a foreign-data wrapper implementation-dependent way.

## 17) Subclause 22.3.3, “AllocWrapperEnv”:

- a) It is implementation-dependent what `AllocWrapperEnv()` makes of the values of `WrapperName WN` and `WrapperLibraryName WL`.

## 18) Subclause 22.3.5, “ConnectServer”:

- a) It is implementation-dependent what use the foreign-data wrapper makes of the values of `AuthorizationID UN`, `ServerName SN`, `ServerType ST`, and `ServerVersion SV`.

## 19) Subclause 22.3.31, “InitRequest”:

- a) If *P* is a <dynamic select statement> or a <dynamic single row select statement>, then a unique implementation-dependent name becomes the cursor name associated with FDW-execution.

## 20) Subclause 22.3.32, “Iterate”:

- a) If an exception condition is raised during the derivation of any target value, then the values of all the bound targets are implementation-dependent and *CR* remains positioned on the current row.

## 21) Subclause 22.4.51, “SetDescriptor”:

- a) If *FI* indicates `TYPE`, then all fields of *IDA* other than those prescribed are set to implementation-dependent values.
- b) If *FI* indicates `DATETIME_INTERVAL_CODE` and the `TYPE` field of *IDA* indicates a <datetime type>, then all the fields of *IDA* other than `DATETIME_INTERVAL_CODE` and `TYPE` are set to implementation-dependent values.
- c) If an exception condition is raised, then the field of *IDA* indicated by *FI* is set to an implementation-dependent value.

*(Blank page)*

## **Annex D**

(informative)

### **Incompatibilities with ISO/IEC 9075:1999**

*This Annex modifies Annex E, “Incompatibilities with ISO/IEC 9075-2:2003”, in ISO/IEC 9075-2.*

This part of ISO/IEC 9075 introduces some incompatibilities with the earlier version of Database Language SQL as specified in ISO/IEC 9075:1999. Unless specified in this Annex, features and capabilities of Database Language SQL are compatible with the earlier version of ISO/IEC 9075:1999.

- 1) A number of additional <reserved word>s have been added to the language. These <reserved word>s are:
  - DLNEWCOPY
  - DLPREVIOUSCOPY
  - DLURLCOMPLETEWRITE
  - DLURLCOMPLETEONLY
  - DLURLPATHWRITE



*(Blank page)*

## Annex E (informative)

### Typical header files

*This Annex modifies Annex A, “Typical header files”, in ISO/IEC 9075-3.*

#### E.1 C Header File SQLCLI.H

*This Subclause modifies Subclause A.1, “C header file SQLCLI.H”, in ISO/IEC 9075-3.*

Add the following manifest constants

```
/* API declaration data types */
typedef unsigned char SQLDATALINK;
/* datalink attributes */
#define SQL_ATTR_DL_URL_COMPLETE 3
#define SQL_ATTR_DL_URL_PATH 4
#define SQL_ATTR_DL_URL_PATH_ONLY 5
#define SQL_ATTR_DL_URL_SCHEME 6
#define SQL_ATTR_DL_URL_SERVER 7
/* SQL data type codes */
#define SQL_DATALINK 70
/* GetFunctions values to identify CLI routines */
#define SQL_API_SQLBUILDDATALINK 1029
#define SQL_API_SQLGETDATALINKATTR 1034
/* Information requested by GetInfo() */
#define SQL_MAXIMUM_DATALINK_LENGTH 20004
/* Function prototypes */
SQLRETURN SQLBuildDataLink(SQLHSTMT StatementHandle,
 SQLCHAR *DataLocation, SQLINTEGER DataLocationLength,
 SQLCHAR *DataLink, SQLINTEGER DataLinkLength,
 SQLINTEGER *StringLength);
SQLRETURN SQLGetDataLinkAttr(SQLHSTMT StatementHandle,
 SQLSMALLINT Attribute,
 SQLCHAR *DataLink, SQLINTEGER DataLinkLength,
 SQLPOINTER Value, SQLINTEGER BufferLength,
 SQLINTEGER *StringLength);
```

#### E.2 COBOL Library Item SQLCLI

*This Subclause modifies Subclause A.2, “COBOL library item SQLCLI”, in ISO/IEC 9075-3.*

**CD ISO/IEC 9075-9:2007 (E)**  
**E.2 COBOL Library Item SQLCLI**

Add the following definitions

```
* DATALINK ATTRIBUTES
01 SQL-ATTR-DL-URL-COMPLETE PIC S9(4) BINARY VALUE IS 3.
01 SQL-ATTR-DL-URL-PATH PIC S9(4) BINARY VALUE IS 4.
01 SQL-ATTR-DL-URL-PATH-ONLY PIC S9(4) BINARY VALUE IS 5.
01 SQL-ATTR-DL-URL-SCHEME PIC S9(4) BINARY VALUE IS 6.
01 SQL-ATTR-DL-URL-SERVER PIC S9(4) BINARY VALUE IS 7.
* SQL DATA TYPE CODES
01 SQL-DATALINK PIC S9(4) BINARY VALUE IS 70.
* SQLRGETFUNCTIONS VALUES TO IDENTIFY CLI ROUTINES
01 SQL-API-SQLBUILDDATALINK PIC S9(4) BINARY VALUE IS 1029.
01 SQL-API-SQLGETDATALINKATTR PIC S9(4) BINARY VALUE IS 1034.
* INFORMATION REQUESTED BY SQLRGETINFO
01 SQL-MAXIMUM-DATALINK-LENGTH PIC S9(4) BINARY VALUE IS 20004.
```

## Annex F

(informative)

### SQL feature taxonomy

This Annex describes a taxonomy of features and packages defined in this part of ISO/IEC 9075.

Table 39, “Feature taxonomy for optional features”, contains a taxonomy of the features of the SQL language not in Core SQL that are specified in this part of ISO/IEC 9075.

In this table, the first column contains a counter that may be used to quickly locate rows of the table; these values otherwise have no use and are not stable — that is, they are subject to change in future editions of, or even Technical Corrigenda to, ISO/IEC 9075 without notice.

The “Feature ID” column of this table specifies the formal identification of each feature and each subfeature contained in the table.

The “Feature Name” column of this table contains a brief description of the feature or subfeature associated with the Feature ID value.

**Table 39 — Feature taxonomy for optional features**

|           | <b>Feature ID</b> | <b>Feature Name</b>                |
|-----------|-------------------|------------------------------------|
| <b>1</b>  | M001              | Datalinks                          |
| <b>2</b>  | M002              | Datalinks via SQL/CLI              |
| <b>3</b>  | M003              | Datalinks via Embedded SQL         |
| <b>4</b>  | M004              | Foreign data support               |
| <b>5</b>  | M005              | Foreign schema support             |
| <b>6</b>  | M006              | GetSQLString routine               |
| <b>7</b>  | M007              | TransmitRequest                    |
| <b>8</b>  | M009              | GetOpts and GetStatistics routines |
| <b>9</b>  | M010              | Foreign data wrapper support       |
| <b>10</b> | M011              | Datalinks via Ada                  |
| <b>11</b> | M012              | Datalinks via C                    |

|           | <b>Feature ID</b> | <b>Feature Name</b>                                |
|-----------|-------------------|----------------------------------------------------|
| <b>12</b> | M013              | Datalinks via COBOL                                |
| <b>13</b> | M014              | Datalinks via Fortran                              |
| <b>14</b> | M015              | Datalinks via M                                    |
| <b>15</b> | M016              | Datalinks via Pascal                               |
| <b>16</b> | M017              | Datalinks via PL/I                                 |
| <b>17</b> | M018              | Foreign-data wrapper interface routines in Ada     |
| <b>18</b> | M019              | Foreign-data wrapper interface routines in C       |
| <b>19</b> | M020              | Foreign-data wrapper interface routines in COBOL   |
| <b>20</b> | M021              | Foreign-data wrapper interface routines in Fortran |
| <b>21</b> | M022              | Foreign-data wrapper interface routines in MUMPS   |
| <b>22</b> | M023              | Foreign-data wrapper interface routines in Pascal  |
| <b>23</b> | M024              | Foreign-data wrapper interface routines in PL/I    |
| <b>24</b> | M030              | SQL-server foreign data support                    |
| <b>25</b> | M031              | Foreign data wrapper general routines              |

Table 39, “Feature taxonomy for optional features”, does not provide definitions of the features; the definition of those features is found in the Conformance Rules that are further summarized in Annex A, “SQL Conformance Summary”.

## Annex G

### (informative)

### SQL/MED model

This Annex presents annotated diagrams that illustrate the more important concepts of the model of SQL/MED, including the relationships between the SQL-server, foreign-data wrappers, and foreign servers.

This Annex describes the components and interfaces along with representative information flows that are involved in the Management of External Data.

Figure 1, “SQL/MED interfaces”, shows the interfaces and components depicting an environment consisting of an SQL-client and SQL-server, with multiple foreign-data wrappers. Each foreign-data wrapper in turn, is associated with one or more foreign servers. The foreign server interfaces with foreign tables to enable data transfer from an external source.

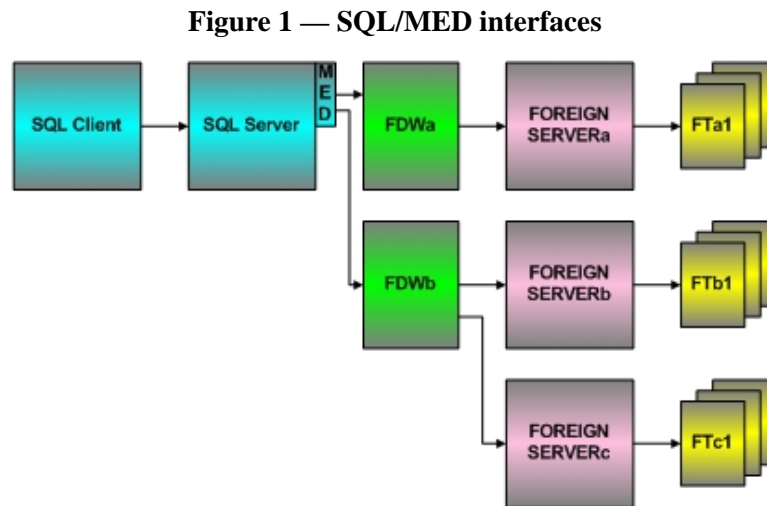

The various components shown in Figure 1, “SQL/MED interfaces”, are documented in Table 40, “Legend for SQL/MED interfaces”.

**Table 40 — Legend for SQL/MED interfaces**

| Notation   | Description                                                             |
|------------|-------------------------------------------------------------------------|
| SQL CLIENT | SQL Client that is involved in MED — interface to user                  |
| SQL SERVER | SQL-server that is involved in MED — interface to foreign-data wrappers |

| Notation               | Description                                                                                             |
|------------------------|---------------------------------------------------------------------------------------------------------|
| MED                    | Management of External Data ISO 9075 SQL/MED Part 9                                                     |
| FDWa                   | Foreign-data wrapper — for interfacing with external data identified by component set A                 |
| FDWb                   | Foreign-data wrapper — for interfacing with external data identified by component sets B and C          |
| FOREIGN SERVERa        | Foreign Server — for interfacing with external data identified by component set A                       |
| FOREIGN SERVERb        | Foreign Server — for interfacing with external data identified by component set B                       |
| FOREIGN SERVERc        | Foreign Server — for interfacing with external data identified by component set C                       |
| FTa1                   | Foreign Tables 1 to n in component set A                                                                |
| FTb1                   | Foreign Tables 1 to n in component set B                                                                |
| FTc1                   | Foreign Tables 1 to n in component set C                                                                |
| →                      | Information Flow via interfaces (generally bi-directional, in spite of the use of single-headed arrows) |
| Diagram box/rectangles | Components involved in Management of External Data                                                      |

Figure 2, “SQL/MED information flow”, shows the information flows along with representative contents of the information flows between the components involved in Management of External Data. An example SQL-environment is shown, consisting of an SQL-client, an SQL-server, foreign-data wrapper, foreign server and foreign tables. Also shown are the information flows from the information schema containing SQL-server information, foreign-data wrapper descriptor information and foreign server descriptor information. Representative contents of each information flow are described.

Figure 2 — SQL/MED information flow

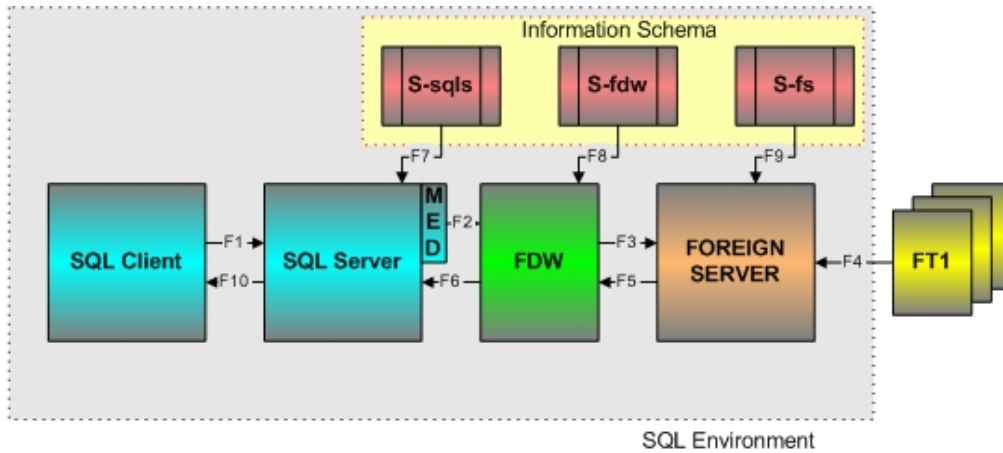

The various components shown in Figure 2, “SQL/MED information flow”, are documented in Table 41, “Legend for SQL/MED information flow”.

Table 41 — Legend for SQL/MED information flow

| Notation | Description                                                  | Content                                                                                                                                                                                                                                       |
|----------|--------------------------------------------------------------|-----------------------------------------------------------------------------------------------------------------------------------------------------------------------------------------------------------------------------------------------|
| F1       | SQL-client — SQL-server communication                        | As defined in ISO/IEC 9075:1999                                                                                                                                                                                                               |
| F2       | Request foreign-data wrapper information                     | Foreign-data wrapper interface routines — SQL-server to foreign-data wrapper                                                                                                                                                                  |
| F3       | Control and get foreign server and foreign table information | Allocate resources<br>De-allocate resources<br>Foreign server connection controls<br>Initiate and terminate execution of SQL statements at foreign server<br>Foreign-data wrapper interface routines — foreign-data wrapper to foreign server |
| F4       | Receive foreign table data                                   | Foreign table data                                                                                                                                                                                                                            |
| F5       | Receive foreign server and foreign table information         | Foreign-data wrapper interface routines — Foreign server to foreign-data wrapper                                                                                                                                                              |
| F6       | Return capabilities and foreign table schema information     | Foreign-data wrapper capabilities<br>Foreign server capabilities<br>Foreign table schema elements<br>Options supported<br>Foreign-data wrapper interface routines — foreign-data wrapper to SQL-server                                        |



| Notation | Description                                         | Content                                                                                                                                                                                                                         |
|----------|-----------------------------------------------------|---------------------------------------------------------------------------------------------------------------------------------------------------------------------------------------------------------------------------------|
| F7       | Receive SQL-server schema information               | Information Schema tables<br>Wrapper handle<br>Execution handle<br>Foreign Server handle<br>User handle<br>Connection handle<br>Table Reference handle<br>Value option handles                                                  |
| F8       | Receive foreign-data wrapper descriptor information | Foreign-data wrapper name<br>Authorization identifier<br>Language name<br>Generic options descriptor<br>Library name                                                                                                            |
| F9       | Receive foreign server descriptor information       | Foreign server name<br>Authorization identifier<br>Foreign-data wrapper name<br>Generic options descriptor<br>Foreign server type<br>Foreign server version<br>Foreign table name<br>Foreign table column name<br>User mappings |
| F10      | SQL-server — SQL-client communication               | As defined in ISO/IEC 9075:1999                                                                                                                                                                                                 |

## Index

Index entries appearing in **boldface** indicate the page where the word, phrase, or BNF nonterminal was defined; index entries appearing in *italics* indicate a page where the BNF nonterminal was used in a Format; and index entries appearing in roman type indicate a page where the word, phrase, or BNF nonterminal was used in a heading, Function, Syntax Rule, Access Rule, General Rule, Leveling Rule, Table, or other descriptive text.

### — A —

<access token indication> • **53**  
 ADA • 401  
 <Ada DATALINK variable> • **185**, 186, 424, 431  
 <Ada derived type specification> • **185**  
 ADD • 90, 91, 111  
 <add basic column definition> • 109, **111**, 442  
 ADMIN • 12, 13, 14, 53, 54, 55, 158, 160, 397, 443  
 ALL • 12, 13, 25, 53, 54, 68, 116, 122, 127, 155, 157, 159, 160, 396, 397  
*allocated query context* • 248  
 ALTER • 109, 113, 121, 126, 132, 140  
 <alter basic column action> • **113**  
 <alter basic column definition> • 109, **113**  
 <alter foreign server statement> • 8, 10, 19, **121**, 149, 371, 425  
 <alter foreign table action> • **109**  
 <alter foreign table statement> • 10, 18, **109**, 110, 111, 149, 372, 424, 442  
 <alter foreign-data wrapper statement> • 9, 10, 19, **126**, 149, 371, 425  
 <alter generic option> • **90**, 91  
 <alter generic option list> • **90**  
 <alter generic options> • **90**, 109, 113, 121, 126, 132, 140, 442  
 <alter operation> • **90**, 91  
 <alter routine mapping statement> • 10, 19, **132**, 149, 371, 425, 443  
 <alter user mapping statement> • 9, 10, 19, **140**, 149, 372, 425, 443  
 AND • 68, 374, 376, 377, 378, 379, 380, 381, 392, 393, 394, 395, 396, 397, 450  
 ANY • 203, 241, 242, 300, 361, 366  
 ARRAY • 171, 191, 207, 208, 209, 210, 215, 218, 219, 224, 225, 363, 395, 396, 450

AS • 172, 176, 220, 221, 223, 374, 376, 377, 378, 379, 380, 381, 382, 383, 384, 385, 386, 387, 388, 389  
 ASC • 315  
 ASENSITIVE • 211  
 ATTRIBUTES • 373, 386, 422, 456

### — B —

<basic column definition> • **106**, 107, 111, 129, 442, 443  
 <basic column definition list> • **106**, 107, 442  
 BIGINT • 194, 195, 208, 209, 210, 364, 393, 396, 446  
 BINARY • 194, 208, 209, 210, 224, 227, 364, 392, 396, 450, 456  
 BLOCKED • 13, 49, 53, 54, 55, 160, 396  
 BOOLEAN • 208, 210, 395, 396  
 BOTH • 162, 309, 318, 326, 332, 334, 335, 338, 347, 359, 362  
 BY • ?, ?, 101, 456

### — C —

C • 242, 244, 401, 443  
 <C DATALINK variable> • **187**, 424, 432  
 <C derived variable> • **187**  
 Feature C001, "CLI routine invocation in Ada" • 417  
 Feature C002, "CLI routine invocation in C" • 417  
 Feature C003, "CLI routine invocation in COBOL" • 417  
 Feature C004, "CLI routine invocation in Fortran" • 417  
 Feature C005, "CLI routine invocation in MUMPS" • 417  
 Feature C006, "CLI routine invocation in Pascal" • 417  
 Feature C007, "CLI routine invocation in PL/I" • 417  
 CARDINALITY • 215, 218  
 CASCADE • 94, 114, 115, 116, 122, 127, 136  
 CAST • 172, 176, 220, 221, 223  
 CATALOG\_NAME • 374, 376, 377, 378, 379, 380, 381  
 CHAR • 185, 191  
 CHARACTER • 189, 192, 194, 201, 203, 208, 209, 210, 220, 223, 224, 241, 242, 244, 265, 266, 278, 293, 298,

301, 309, 316, 318, 323, 324, 326, 328, 329, 330, 332, 334, 336, 338, 342, 343, 345, 347, 349, 352, 355, 356, 357, 359, 364, 368, 392, 396, 447

CHARACTER\_SET\_CATALOG • 71, 72, 73, 214, 217, 220, 222, 223, 283, 288, 289, 290, 362, 363, 364, 386, 387, 443

CHARACTER\_SET\_NAME • 71, 72, 73, 214, 217, 220, 222, 223, 283, 288, 289, 290, 362, 363, 364, 386, 387, 443

CHARACTER\_SET\_SCHEMA • 71, 72, 73, 214, 217, 220, 222, 223, 283, 288, 289, 290, 362, 363, 364, 386, 387, 443

CHECK • 392, 396, 397, 401, 405

CLASS\_ORIGIN • 368, 447

<CLI routine> • **193**, 194

*CLI-specific condition* • 201, 203, 413

COBOL • 44, 188, 241, 243, 401, 417, 418, 432, 433

<COBOL DATALINK variable> • **188**, 424, 432

<COBOL derived type specification> • **188**

COLLATION\_CATALOG • 214, 218, 386, 387, 392, 393, 394, 395

COLLATION\_NAME • 214, 218, 386, 387, 392, 393, 394, 395

COLLATION\_SCHEMA • 214, 218, 386, 387, 392, 393, 394, 395

COLUMN • 111, 113, 114

<column generic options> • **106**, 107, 111, 129

*column name not found* • 310, 333, 335, 414

<column option list> • **95**

COLUMN\_NAME • 24, 25, 349, 374, 386, 387, 391

<commercial at> • **76**

<common value expression> • **58**

CONSTRAINT • 391, 392, 396, 397, 400, 401, 402, 403, 404, 405, 406, 407, 411, 412

CONTROL • 12, 13, 49, 53, 54, 55, 155, 157, 159

CONVERT • 223

CORRESPONDING • 114

COUNT • 44, 71, 72, 168, 169, 170, 174, 213, 216, 219, 222, 283, 288, 290, 300, 301, 361, 363

CREATE • 101, 106, 119, 124, 130, 138, 374, 376, 377, 378, 379, 380, 381, 382, 383, 384, 385, 386, 387, 388, 389, 391, 400, 401, 402, 403, 404, 405, 406, 407, 411, 412

CURRENT\_CATALOG • 211

CURRENT\_DEFAULT\_TRANSFORM\_GROUP • 211

CURRENT\_PATH • 211

CURRENT\_ROLE • 211

CURRENT\_SCHEMA • 211

CURRENT\_TRANSFORM\_GROUP\_FOR\_TYPE • 211, 215, 218

CURRENT\_USER • 138, 211, 374, 376, 377, 378, 379, 380, 381

CURSOR • 211

## — D —

DATA • ?, 119, 124, 126, 127, 135, 171, 172, 173, 175, 208, 209, 213, 217, 220, 223, 224, 362, 363, 364, 450, 456

*data exception* • 64, 65, 224, 413, 444

<data location> • **64**

DATALINK • ?, ?, 5, 6, 7, 11, 12, 14, 15, 49, 53, 54, 63, 64, 79, 80, 81, 82, 98, 155, 157, 159, 163, 169, 194, 195, 205, 208, 209, 210, 215, 218, 395, 396, 397, 408, 424, 441, 443, 456

<datalink control definition> • **53**, 54, 56, 95, 99, 102, 104, 145

*datalink exception* • 65, 155, 157, 159, 160, 413, 442, 443

<datalink file control option> • **53**, 54, 157, 160

<datalink type> • **53**, 54, 55, 185, 187, 188, 189, 190, 191, 192, 422

<datalink value constructor> • 12, 16, **64**, 66, 449

*datalink value exceeds maximum length* • 65, 413

<datalink value expression> • 58, 59, 60, **63**, 422

<datalink value function> • 63, **64**, 66, 422, 449

DATE • 364, 394, 396

DATETIME\_INTERVAL\_CODE • 71, 72, 73, 214, 218, 220, 222, 283, 288, 289, 290, 363, 364, 365, 451

DATETIME\_INTERVAL\_PRECISION • 71, 73, 214, 218, 220, 222, 283, 288, 289, 290, 363, 364, 365

DATETIME\_INTERVAL\_PRECISON • 363

DAY • 365, 394

DB • 12, 13, 49, 53, 54, 55, 158, 160, 396, 397

DECIMAL • 208, 209, 210, 364, 393, 396, 446

DECLARE • 211

DEFAULT • 194, 208, 219, 286

DEFERRED • 194

DEFINED • 194, 195, 208, 209, 210, 214, 218, 395, 396, 398

DEGREE • 208, 209, 210, 215, 218, 363

DELETE • 13, 14, 54, 55, 98, 155, 159, 397

*dependent privilege descriptors still exist* • 136

DESCRIBE • 194

<digits> • **75**

DISTINCT • 15, 25, 68, 302

DLNEWCOPY • 12, 13, 16, 49, 64, 65, 453

DLPREVIOUSCOPY • 12, 13, 16, 49, 64, 65, 453

DLURLCOMPLETE • 49, 59

DLURLCOMPLETEONLY • 49, 59, 453

DLURLCOMPLETEWRITE • 49, 59

DLURLPATH • 49, 59

DLURLPATHONLY • 49, 59  
 DLURLPATHWRITE • 49, 59, 453  
 DLURLSCHEME • 49, 59  
 DLURLSERVER • 49, 59  
 DLVALUE • 16, 49, 64, 65  
 <dollar sign> • **76**  
 <domain label> • **75**  
 DOUBLE • 194, 195, 208, 209, 210, 364, 393, 396, 446  
 DROP • 90, 91, 94, 103, 114, 115, 116, 122, 127, 133, 136, 141  
 <drop basic column definition> • 109, **114**, 115  
 <drop foreign server statement> • 8, 19, **122**, 123, 136, 149, 372, 425  
 <drop foreign table statement> • 18, 94, **116**, 117, 136, 149, 372, 424  
 <drop foreign-data wrapper statement> • 9, 19, **127**, 149, 372, 425  
 <drop routine mapping statement> • 10, 19, 103, 122, **133**, 149, 372, 425, 443  
 <drop user mapping statement> • 9, 19, 122, **141**, 149, 372, 426, 443  
*dynamic parameter value needed* • 414  
*dynamic SQL error* • 170, 171, 172, 174, 175, 176, 219, 222, 300, 361, 363  
 DYNAMIC\_FUNCTION • 213, 216  
 DYNAMIC\_FUNCTION\_CODE • 213, 216

## — E —

ELEMENT • 266, 278  
 <escape> • **76**  
 EXCEPT • 15, 128, 129  
 <exclamation point> • **76**  
 EXECUTE • 219, 291  
*external file already linked* • 157, 160, 413  
*external file not linked* • 155, 159, 413  
 <extra> • **76**

## — F —

Feature F391, "Long identifiers" • 376, 377, 378, 379, 380, 381, 382, 383, 384, 385, 386, 421, 422  
*FDW-specific condition* • ?, 42, 44, 71, 72, 73, 74, 128, 129, 226, 227, 245, 246, 248, 249, 251, 252, 253, 254, 256, 257, 258, 259, 260, 261, 262, 263, 264, 267, 268, 269, 270, 271, 272, 273, 274, 275, 276, 277, 278, 280, 281, 282, 284, 285, 286, 288, 289, 290, 291, 292, 293, 296, 297, 298, 299, 300, 302, 303, 304, 305, 306, 307, 308, 309, 310, 311, 312, 313, 314, 315, 316, 318, 319, 320, 321, 322, 323, 324, 326, 327, 328, 329, 330, 332, 333, 334, 335, 336, 338, 340, 341, 342, 343, 344, 345, 347, 348, 349, 350, 351, 352, 353, 354, 355, 356, 357, 359, 360, 361, 362, 364, 366, 367, 368, 414, 451

*FDW-specific exception* • 265  
 FETCH • 222  
 FILE • 12, 13, 49, 53, 54, 75, 155, 157, 159  
 <file> • 62, 65, **76**  
 <file url> • 61, 62, 65, 75, **76**  
 FLOAT • 208, 209, 210, 364, 393, 396, 446  
 FOR • 13, 14, 53, 55, 101, 122, 130, 138, 141, 158, 160, 211, 397, 443  
 FOREIGN • ?, 94, 106, 109, 116, 119, 124, 126, 127, 128, 135, 136, 391, 400, 402, 403, 404, 405, 406, 407, 409, 411, 412  
 <foreign schema name> • **128**  
 <foreign server definition> • 7, 8, 10, 19, 31, **119**, 120, 149, 372, 425, 443  
 <foreign server name> • 21, **51**, 52, 106, 107, 119, 121, 122, 128, 130, 135, 136, 138, 140, 141, 162, 323, 356  
 <foreign table definition> • 8, 10, 18, 93, **106**, 107, 108, 129, 149, 372, 424, 442  
 <foreign-data wrapper definition> • 9, 10, 19, 30, **124**, 125, 149, 372, 425, 443  
 <foreign-data wrapper interface routine> • **239**, 241, 242, 243, 244, 245, 247, 248, 250, 251, 253, 255, 256, 257, 258, 259, 260, 261, 262, 263, 264, 266, 267, 268, 269, 270, 271, 272, 273, 274, 275, 276, 277, 279, 280, 281, 285, 287, 291, 292, 295, 296, 297, 298, 299, 301, 302, 303, 304, 305, 306, 307, 308, 310, 311, 312, 313, 314, 315, 317, 319, 320, 321, 322, 323, 325, 327, 328, 329, 331, 333, 335, 337, 339, 340, 341, 342, 343, 344, 346, 348, 349, 350, 351, 352, 353, 354, 355, 356, 358, 360, 365, 369, 427, 428, 429, 430, 431, 432, 433, 434, 435, 436, 437, 438, 439, 444, 450  
 <foreign-data wrapper interface routine generic> • **239**, 242  
 <foreign-data wrapper interface routine name> • **239**, 241, 242, 244, 247, 248, 250, 251, 253, 255, 256, 257, 258, 259, 260, 261, 262, 263, 264, 266, 267, 268, 269, 270, 271, 272, 273, 274, 275, 276, 277, 279, 280, 281, 285, 287, 291, 292, 295, 296, 297, 298, 299, 301, 302, 303, 304, 305, 306, 307, 308, 310, 311, 312, 313, 314, 315, 317, 319, 320, 321, 322, 323, 325, 327, 328, 329, 331, 333, 335, 337, 339, 340, 341, 342, 343, 344, 346, 348, 349, 350, 351, 352, 353, 354, 355, 356, 358, 360, 365, 369, 427, 428, 429, 430, 431, 434, 435, 436, 437, 438, 439  
 <foreign-data wrapper interface routine prefix> • **239**, 242  
 <foreign-data wrapper name> • **51**, 52, 119, 124, 126, 127, 135  
 <foreign-data wrapper parameter data type> • **241**, 244  
 <foreign-data wrapper parameter declaration> • **241**, 244  
 <foreign-data wrapper parameter list> • 239, **241**  
 <foreign-data wrapper parameter mode> • **241**, 242  
 <foreign-data wrapper parameter name> • **241**  
 <foreign-data wrapper returns clause> • 239, **241**

FORTRAN • 401  
 <Fortran DATALINK variable> • **189**, 424, 432  
 <Fortran derived type specification> • **189**  
 <fpath> • 61, 62, 65, **76**, 449  
 FROM • 22, 68, 115, 116, 122, 127, 128, 162, 309, 318,  
 326, 332, 334, 335, 338, 347, 359, 362, 374, 376, 377,  
 378, 379, 380, 381, 382, 383, 384, 385, 386, 387, 388,  
 389, 405, 450  
 FS • 12, 13, 49, 53, 54, 55, 379, 396, 397  
 <fsegment> • **76**  
 <fsegment character> • **76**  
 FULL • 101  
 FUNCTION • 101  
*function sequence error* • 251, 256, 257, 259, 286, 288,  
 414

— G —

<generic option> • **89**  
 <generic option list> • **89**  
 <generic options> • **89**, 90, 106, 119, 120, 124, 130, 138  
 GO • 124  
 GRANT • 374, 376, 377, 378, 379, 380, 381, 382, 383,  
 384, 385, 386, 387, 388, 389

— H —

HOLD • 211  
 <host> • 62, 65, **75**, 76  
 <host name> • **75**  
 <host number> • **75**  
 <host port> • **75**  
 HOUR • 365, 394  
 <hpath> • 61, 62, 65, **75**, 449  
 <hsegment> • **75**, **76**  
 <hsegment character> • **76**  
 <http> • 62, 65, **75**  
 <http url> • 61, 62, 65, **75**

— I —

IMPORT • 49, 128  
 <import foreign schema statement> • 8, 18, **128**, 129, 372,  
 425, 427  
 <import qualifications> • **128**, 129  
 IN • 201, 203, 241, 246, 248, 249, 251, 252, 254, 256,  
 257, 258, 259, 260, 261, 262, 263, 264, 265, 267, 268,  
 269, 270, 271, 272, 273, 274, 275, 276, 277, 278, 280,  
 281, 282, 286, 288, 292, 293, 296, 297, 298, 299, 300,  
 302, 303, 304, 305, 306, 307, 308, 309, 311, 312, 313,  
 314, 315, 316, 318, 320, 321, 322, 323, 324, 326, 328,  
 329, 330, 332, 334, 336, 338, 340, 341, 342, 343, 344,  
 345, 347, 349, 350, 351, 352, 353, 354, 355, 356, 357,

359, 361, 366, 374, 376, 377, 378, 379, 380, 381, 392,  
 393, 394, 395, 396, 397, 401, 405  
*inconsistent descriptor information* • 364, 414  
 INDICATOR • 171, 208, 213, 217, 219, 223, 362  
 INOUT • 241, 242  
 INSERT • 408  
*insufficient item descriptor areas* • 168, 169  
 INTEGER • 21, 194, 195, 201, 203, 204, 208, 209, 210,  
 241, 242, 246, 248, 249, 251, 252, 254, 256, 257, 258,  
 259, 260, 261, 262, 263, 264, 265, 266, 267, 268, 269,  
 270, 271, 272, 273, 274, 275, 276, 277, 278, 280, 281,  
 282, 286, 288, 292, 293, 296, 297, 298, 299, 300, 302,  
 303, 304, 305, 306, 307, 308, 309, 311, 312, 313, 314,  
 315, 316, 318, 320, 321, 322, 323, 324, 326, 328, 329,  
 330, 332, 334, 336, 338, 340, 341, 342, 343, 344, 345,  
 347, 349, 350, 351, 352, 353, 354, 355, 356, 357, 359,  
 361, 364, 366, 393, 396, 446  
 INTEGRITY • 13, 49, 53, 54, 155, 157, 159, 160  
 <integrity control option> • **53**  
 INTERFACE • ?  
 INTERSECT • 15  
 INTERVAL • 214, 218, 364, 365, 394, 396  
 INTO • 128  
*invalid attribute identifier* • 203  
*invalid attribute value* • 367, 414  
*invalid catalog name* • 362  
*invalid character set name* • 362  
*invalid column name* • 309, 332, 334, 414  
*invalid column number* • 414  
*invalid condition number* • 367  
*invalid cursor allocation* • 180, 415  
*invalid cursor option* • 179, 415  
*invalid cursor state* • 251  
*invalid data specified for datalink* • 65, 413  
*invalid data type* • 364, 414  
*invalid data type descriptors* • 71, 72, 73, 74, 289, 290,  
 291, 414  
*invalid datalink construction* • 157, 413  
*invalid datalink value* • 201, 203, 413  
*invalid descriptor count* • 171, 175, 219, 222  
*invalid descriptor field identifier* • 300, 361, 414  
*invalid descriptor index* • 300, 361  
*invalid foreign server specification* • 162, 415  
*invalid handle* • 42, 245, 246, 248, 249, 252, 254, 256,  
 257, 258, 259, 260, 261, 262, 263, 264, 265, 267, 268,  
 269, 270, 271, 272, 273, 274, 275, 276, 277, 278, 280,  
 281, 282, 288, 292, 293, 297, 298, 299, 302, 303, 304,  
 305, 306, 307, 308, 309, 311, 312, 313, 314, 315, 316,  
 318, 320, 321, 322, 323, 324, 326, 328, 329, 330, 332,  
 334, 336, 338, 340, 341, 342, 343, 344, 345, 347, 349,

350, 351, 352, 353, 354, 355, 356, 357, 359, 366, 367, 414

*invalid handle* • 42

*invalid LEVEL value* • 363

*invalid option index* • 267, 272, 274, 275, 299, 315, 316, 321, 324, 333, 336, 340, 345, 354, 357, 414

*invalid option name* • 318, 326, 335, 338, 347, 359, 414

*invalid parameter value* • 64

*invalid schema name* • 362

*invalid SQL descriptor name* • 168

*invalid string format* • 330, 414

*invalid string length or buffer length* • 203, 226, 227, 309, 318, 326, 332, 334, 335, 338, 347, 359, 362, 368, 414

*invalid use of null pointer* • 44, 414

*invalid write permission for update* • 160, 414

*invalid write token* • 65, 160, 413, 442, 443

IS • 185, 187, 188, 189, 190, 191, 192, 392, 393, 394, 395, 396, 456

## — K —

KEY • 391, 400, 401, 402, 403, 404, 405, 406, 407, 411, 412

KEY\_MEMBER • 213, 214, 217

KEY\_TYPE • 213, 216

## — L —

<label tail> • 75

LARGE • 194, 208, 209, 210, 224, 227, 364, 392, 396, 450

LENGTH • 71, 72, 73, 169, 194, 205, 214, 215, 217, 218, 220, 222, 283, 288, 289, 290, 363, 364, 408, 424, 443, 456

<letter or digit> • 75

LEVEL • 171, 175, 207, 208, 209, 213, 214, 217, 219, 220, 222, 223, 286, 363

LIBRARY • 49, 124

<library name> • 124, 126

<library name specification> • 124, 126

LIMIT • 49, 128, 129

*limit on number of handles exceeded* • 248, 249, 253, 284, 293, 296, 414, 451

LINK • 12, 13, 49, 53, 54, 55, 155, 157, 159

<local schema name> • 128

LOCATOR • 171, 194, 195, 208, 209, 210, 219, 224, 225, 363, 450

## — M —

M • 190, 418, 432

Feature M001, "Datalinks" • 55, 63, 66, 373, 375, 389, 390, 422, 423

Feature M002, "Datalinks via SQL/CLI" • 202, 204, 205, 417, 423, 424

Feature M003, "Datalinks via Embedded SQL" • 186, 187, 188, 189, 190, 191, 192, 417, 424

Feature M004, "Foreign data support" • 108, 110, 117, 120, 121, 123, 125, 126, 127, 129, 131, 132, 133, 139, 140, 141, 162, 374, 376, 377, 378, 379, 380, 381, 382, 383, 384, 385, 390, 417, 418, 424, 425, 426, 427

Feature M005, "Foreign schema support" • 129, 427

Feature M006, "GetSQLString routine" • 331, 427

Feature M007, "TransmitRequest" • 295, 428

Feature M009, "GetOpts and GetStatistics routines" • 266, 279, 428

Feature M010, "Foreign-data wrapper support" • 247, 248, 250, 251, 253, 255, 256, 257, 258, 259, 260, 261, 262, 263, 264, 267, 268, 269, 270, 271, 272, 273, 274, 275, 276, 277, 280, 281, 285, 287, 291, 292, 417, 418, 428, 429, 430, 431

Feature M011, "Datalinks via Ada" • 186, 417, 431

Feature M012, "Datalinks via C" • 187, 417, 431, 432

Feature M013, "Datalinks via COBOL" • 188, 417, 432

Feature M014, "Datalinks via Fortran" • 189, 417, 432

Feature M015, "Datalinks via M" • 190, 418, 432

Feature M016, "Datalinks via Pascal" • 191, 418, 432

Feature M017, "Datalinks via PL/I" • 192, 418, 432

Feature M018, "Foreign-data wrapper interface routines in Ada" • 243, 418, 432

Feature M019, "Foreign-data wrapper interface routines in C" • 243, 418, 432, 433

Feature M020, "Foreign-data wrapper interface routines in COBOL" • 243, 418, 433

Feature M021, "Foreign-data wrapper interface routines in Fortran" • 243, 418, 433

Feature M022, "Foreign-data wrapper interface routines in MUMPS" • 243, 418, 433

Feature M023, "Foreign-data wrapper interface routines in Pascal" • 243, 418, 433

Feature M024, "Foreign-data wrapper interface routines in PL/I" • 243, 418, 433, 434

Feature M030, "SQL-server foreign data support" • 296, 297, 298, 299, 301, 302, 303, 304, 305, 306, 307, 308, 310, 311, 312, 313, 314, 315, 317, 319, 320, 321, 322, 323, 325, 327, 328, 329, 333, 335, 337, 339, 340, 341, 342, 343, 344, 346, 348, 349, 350, 351, 352, 353, 354, 355, 356, 358, 360, 365, 417, 418, 434, 435, 436, 437, 438, 439

Feature M031, "Foreign-data wrapper general routines" • 369, 418, 439

MAP • 101

MAPPING • 49, 103, 122, 130, 132, 133, 138, 140, 141

MED • 239

*memory allocation error* • 248, 249, 253, 284, 293, 296, 362, 414  
 MESSAGE\_LENGTH • 368  
 MESSAGE\_OCTET\_LENGTH • 368  
 MESSAGE\_TEXT • 368, 447  
 MINUTE • 365, 394  
 MONTH • 394  
 MORE • 367  
 MULTISSET • 171, 207, 208, 209, 210, 219, 224, 225, 363, 396, 450  
 MUMPS • 243, 401, 417, 418, 433  
 <MUMPS DATALINK variable> • **190**, 424, 432  
 <MUMPS derived type specification> • **190**

— N —

NAME • 213, 214, 217, 450  
 NATURAL • 114  
 <new version> • **121**  
 NO • 12, 13, 14, 53, 54, 55, 211, 397  
*no data* • 42, 43, 245, 265, 267, 272, 274, 275, 278, 287, 299, 300, 315, 316, 321, 324, 333, 336, 340, 345, 354, 357, 367  
*no schemas* • 128, 414  
*no subclass* • 413, 414, 415  
 <non-reserved word> • **49**  
 NONE • 12, 13, 14, 55, 396, 397  
 NOT • ?, 13, 14, 53, 55, 158, 160, 392, 393, 394, 395, 396, 397, 401, 403  
 NULL • ?, 194, 208, 209, 220, 224, 392, 393, 394, 395, 396, 401, 403, 450  
*null argument passed to datalink constructor* • 64, 413  
 NULLABLE • 213, 214, 217  
 NUMBER • 367  
 NUMERIC • 208, 209, 210, 364, 393, 396, 446

— O —

OBJECT • 194, 208, 209, 210, 224, 227, 364, 392, 396, 450  
 <object name> • **135**  
 OCTET\_LENGTH • 71, 72, 73, 169, 194, 208, 213, 214, 215, 217, 218, 220, 223, 283, 288, 289, 290, 362, 363, 443  
 OF • 191  
 OFF • 21, 49, 161  
 ON • 14, 54, 55, 115, 116, 122, 127, 374, 376, 377, 378, 379, 380, 381, 382, 383, 384, 385, 386, 387, 388, 389  
 ONLY • 67, 204, 456  
 OPEN • 211, 219, 291  
 OPTION • 374, 376, 377, 378, 379, 380, 381, 382, 383, 384, 385, 386, 387, 388, 389

<option name> • **51**, 89, 90, 91, 442  
*option name not found* • 319, 327, 335, 338, 348, 360, 414  
 <option value> • **89**, 90, 91  
 OPTIONS • 89, 90  
 OR • 374, 376, 377, 378, 379, 392, 393, 394, 395, 396, 397  
 ORDER • 101  
 ORDERING • 101  
 OUT • 201, 203, 241, 246, 248, 249, 252, 260, 261, 262, 263, 264, 265, 267, 268, 269, 270, 271, 272, 273, 274, 275, 276, 277, 278, 280, 281, 282, 293, 296, 298, 299, 300, 302, 303, 304, 305, 306, 307, 308, 309, 311, 312, 313, 314, 315, 316, 318, 320, 321, 322, 323, 324, 326, 328, 329, 330, 332, 334, 336, 338, 340, 341, 342, 343, 344, 345, 347, 349, 350, 351, 352, 353, 354, 355, 356, 357, 359, 366

— P —

PARAMETER • 24, 25  
 PARAMETER\_MODE • 213, 363  
 PARAMETER\_ORDINAL\_POSITION • 213, 363  
 PARAMETER\_SPECIFIC\_CATALOG • 213, 363  
 PARAMETER\_SPECIFIC\_NAME • 213, 363  
 PARAMETER\_SPECIFIC\_SCHEMA • 213, 363  
 PASCAL • 401  
 <Pascal DATALINK variable> • **191**, 424, 432  
 <Pascal derived type specification> • **191**  
*pass-through specific condition* • 179, 180, 415  
 PASSTHROUGH • 22, 49, 161, 222, 254, 285, 286, 288, 294  
 <passthrough specification> • **161**  
 PATH • 204, 456  
 PERMISSION • 13, 49, 53, 54, 55, 157, 160  
 <PL/I DATALINK variable> • **192**, 424, 432  
 <PL/I derived type specification> • **192**  
 PLI • 401  
 <port> • **75**  
 PRECISION • 71, 72, 73, 194, 195, 208, 209, 210, 214, 218, 219, 220, 222, 223, 283, 287, 288, 289, 290, 363, 364, 365, 393, 396, 446  
 <predefined type> • **53**  
 PRIMARY • 391, 400, 401, 402, 403, 404, 405, 406, 407, 411, 412  
 PRIVILEGES • 116, 122, 127  
 PUBLIC • 9, 68, 138, 140, 141, 166, 374, 376, 377, 378, 379, 380, 381, 382, 383, 384, 385, 386, 387, 388, 389

— R —

READ • 13, 53, 54, 55, 157, 160  
 <read permission option> • **53**

REAL • 194, 195, 208, 209, 210, 364, 393, 396, 446  
 RECOVERY • 13, 14, 49, 53, 54, 55  
 <recovery option> • **53**  
 REF • 194, 195, 208, 209, 210, 214, 218, 395, 396  
*referenced file does not exist* • 157, 159, 414  
*referenced file not valid* • 160, 414  
 REFERENCES • 391, 400, 402, 403, 404, 405, 406, 407, 411, 412  
*reply handle* • 415  
 REQUIRING • 13, 14, 49, 53, 55, 158, 160, 397, 443  
 <reserved word> • **49**, 453  
 RESTORE • 13, 14, 49, 54, 55, 98, 155, 159, 397  
 RESTRICT • 94, 114, 116, 122, 127  
*restricted data type attribute violation* • 172, 175, 176  
 RETURNED\_CARDINALITY • 213, 225, 362  
 RETURNS • 201, 203, 241, 246, 248, 249, 251, 252, 254, 256, 257, 258, 259, 260, 261, 262, 263, 264, 265, 267, 268, 269, 270, 271, 272, 273, 274, 275, 276, 277, 278, 280, 281, 282, 286, 288, 292, 293, 296, 297, 298, 299, 300, 302, 303, 304, 305, 306, 307, 308, 309, 311, 312, 313, 314, 315, 316, 318, 320, 321, 322, 323, 324, 326, 328, 329, 330, 332, 334, 336, 338, 340, 341, 342, 343, 344, 345, 347, 349, 350, 351, 352, 353, 354, 355, 356, 357, 359, 361, 366  
 REVOKE • 115, 116, 122, 127  
 ROUTINE • 103, 115, 116, 122, 130, 132, 133  
 <routine mapping definition> • 10, 19, **130**, 131, 149, 372, 425, 443  
 <routine mapping name> • **51**, 52, 130, 132, 133  
 ROW • 16, 71, 73, 171, 207, 208, 209, 210, 215, 218, 219, 220, 224, 289, 290, 363, 396, 450

## — S —

<safe> • **76**  
 SCALE • 71, 72, 73, 208, 209, 210, 214, 218, 219, 220, 222, 223, 283, 287, 288, 289, 290, 363, 364, 446  
 SCHEMA • 128, 222  
 <schema element> • **93**  
*schema not found* • 128, 415  
 SCOPE\_CATALOG • 71, 72, 73, 214, 218, 220, 222, 223, 283, 288, 289, 290, 363, 386, 387, 392, 393, 394, 395, 396  
 SCOPE\_NAME • 71, 72, 73, 214, 218, 220, 222, 223, 283, 288, 289, 290, 363, 386, 387, 392, 393, 394, 395, 396  
 SCOPE\_SCHEMA • 71, 72, 73, 214, 218, 220, 222, 223, 283, 288, 289, 290, 363, 386, 387, 392, 393, 394, 395, 396  
 SCROLL • 211  
 SECOND • 365, 394

SELECT • 22, 68, 108, 111, 114, 115, 374, 376, 377, 378, 379, 380, 381, 382, 383, 384, 385, 386, 387, 388, 389, 405, 450  
 SELECTIVE • 12, 13, 49, 53, 54, 157, 159, 160, 396, 397  
 SERVER • 49, 106, 119, 121, 122, 128, 130, 135, 136, 138, 140, 141, 204, 265, 366, 456  
 <server type> • **119**, 120, 443  
 <server version> • **119**, 120, 121, 443  
 SESSION\_USER • 211  
 SET • 90, 91, 161  
 <set passthrough statement> • 19, 21, 149, **161**, 162, 165, 372, 426  
 SMALLINT • 194, 195, 201, 203, 208, 209, 210, 241, 242, 246, 248, 249, 251, 252, 254, 256, 257, 258, 259, 260, 261, 262, 263, 264, 265, 267, 268, 269, 270, 271, 272, 273, 274, 275, 276, 277, 278, 280, 281, 282, 286, 288, 292, 293, 296, 297, 298, 299, 300, 302, 303, 304, 305, 306, 307, 308, 309, 311, 312, 313, 314, 315, 316, 318, 320, 321, 322, 323, 324, 326, 328, 329, 330, 332, 334, 336, 338, 340, 341, 342, 343, 344, 345, 347, 349, 350, 351, 352, 353, 354, 355, 356, 357, 359, 361, 364, 366, 393, 396, 446  
 SPECIFIC • 115, 116  
 <specific or generic authorization identifier> • **138**, 140, 141  
 SPECIFIC\_NAME • 383, 389, 407  
 SQL • 185, 187, 188, 189, 190, 191, 192  
 <SQL schema definition statement> • **149**  
 <SQL schema manipulation statement> • **149**  
 <SQL session statement> • **149**  
 SQLSTATE • ?, 42, 368, 441  
*string data, right truncation* • 226, 227, 362  
 <string value function> • **59**, 60, 449  
 SUBCLASS\_ORIGIN • 368, 447  
*successful completion* • 245  
 SYSTEM • 108, 114, 116, 120, 122, 124, 127  
 SYSTEM\_USER • 211

## — T —

TABLE • 94, 106, 109, 115, 116, 136, 374, 376, 377, 378, 379, 380, 381, 382, 383, 384, 385, 386, 387, 388, 389, 391, 398, 400, 401, 402, 403, 404, 405, 406, 407, 411, 412  
 <table generic options> • **106**, 107, 129  
 <table name list> • **128**, 129  
*table not found* • 129, 415  
 TABLE\_NAME • 24, 342, 374, 380, 381, 386, 387, 391, 405  
 TIME • 364, 365, 394, 396  
 TIMESTAMP • 365, 394, 396



TO • 128, 129, 365, 374, 376, 377, 378, 379, 380, 381, 382, 383, 384, 385, 386, 387, 388, 389, 394, 456  
TOKEN • 13, 14, 49, 53, 55, 158, 160, 397, 443  
<token indication> • 64  
<top label> • 75  
TOP\_LEVEL\_COUNT • 69, 208, 209, 213, 216, 286  
TRIGGER • 114  
TRIM • 162, 309, 318, 326, 332, 334, 335, 338, 347, 359, 362  
TYPE • 71, 72, 73, 119, 163, 169, 171, 185, 187, 188, 189, 190, 191, 192, 194, 195, 208, 209, 210, 213, 214, 215, 217, 218, 219, 220, 222, 223, 224, 225, 283, 286, 287, 288, 289, 290, 361, 363, 364, 365, 367, 398, 443, 444, 445, 446, 450, 451, 456

— U —

<uchar> • 76  
*unable to create execution* • 284, 285, 415  
*unable to create reply* • ?  
*unable to create reply* • 284, 293, 415  
*unable to establish connection* • 253, 415  
UNION • 15, 380, 381  
UNIQUE • 407  
UNLINK • 14, 49, 54, 55  
<unlink option> • 53, 54  
UNNAMED • 213, 214, 217, 450  
<unqualified foreign server name> • 51  
<unqualified foreign-data wrapper name> • 51  
<unreserved> • 76  
UPDATE • 13, 14, 53, 55, 158, 160, 397, 443  
UPPER • 242  
<url> • 75, 77  
<url complete expression> • 15, 59, 60, 442  
<url complete for write expression> • 15, 59, 60, 442  
<url complete only expression> • 15, 59, 60, 61, 442  
<url path expression> • 15, 59, 60, 61, 442  
<url path for write expression> • 15, 59, 60, 61, 442  
<url path only expression> • 15, 59, 60, 61, 442  
<url scheme expression> • 15, 59, 60, 62, 442  
<url server expression> • 15, 59, 60, 62, 442  
USAGE • 107, 119, 120, 124, 130, 135, 136, 138, 162, 188  
USER • 122, 138, 140, 141, 366  
<user mapping definition> • 9, 10, 19, 31, 138, 139, 149, 372, 425, 443  
USER\_DEFINED\_TYPE\_CATALOG • 71, 72, 73, 214, 218, 220, 222, 223, 283, 288, 289, 290, 363, 392, 393, 394, 395, 396

USER\_DEFINED\_TYPE\_NAME • 71, 72, 73, 214, 218, 220, 222, 223, 283, 288, 289, 290, 363, 392, 393, 394, 395, 396  
USER\_DEFINED\_TYPE\_SCHEMA • 71, 72, 73, 214, 218, 220, 223, 283, 288, 289, 290, 363, 392, 393, 394, 395, 396  
USING • 194, 219, 222, 223  
*using clause does not match dynamic parameter specifications* • 170, 171, 219  
*using clause does not match target specifications* • 174, 175, 222

— V —

VALUE • 456  
VALUES • 456  
VARCHAR • 190  
VARYING • 223, 242, 265, 278, 293, 301, 330, 364, 368, 392, 396, 447  
VERSION • 49, 119, 121  
VIEW • 374, 376, 377, 378, 379, 380, 381, 382, 383, 384, 385, 386, 387, 388, 389

— W —

*warning* • 42, 43, 168, 169, 226, 227, 245, 362  
WHERE • 68, 374, 376, 377, 378, 379, 380, 381, 405, 450  
WITH • 101, 364, 365, 374, 376, 377, 378, 379, 380, 381, 382, 383, 384, 385, 386, 387, 388, 389, 394  
WITHOUT • 211  
WRAPPER • ?, 49, 119, 124, 126, 127, 135, 265, 367  
WRITE • 13, 53, 54, 55, 157, 160  
<write permission option> • 53

— X —

XML • ?

— Y —

YEAR • 394  
YES • 13, 49, 54, 55, 397

— Z —

*zero-length character string* • 224, 444  
ZONE • 364, 365, 394